

**STATE OF ALASKA ITB NUMBER 2526H255
AMENDMENT NUMBER ONE (1)**

AMENDMENT ISSUING OFFICE:



Department of Transportation & Public Facilities
Statewide Contracting & Procurement
P.O. Box 112500
(3132 Channel Drive, Room 350)
Juneau, Alaska 99811-2500

THIS IS NOT AN ORDER

DATE AMENDMENT ISSUED: April 22, 2026

ITB TITLE: ANCHORAGE TAXIWAY Q RECONSTRUCTION SUPPLIES

DUE DATE: April 30, 2026 at 2:00 PM. (Alaska Time)

This is a mandatory return Amendment. *Your bid may be considered non-responsive if this signed amendment is not received [in addition to your bid] by the date and time bids are due.*

Vendor Signature: _____

Date: _____

Printed Name: _____

Offerors Name: _____

The purpose of this Amendment #1 is to:

- **Provide answers to questions received**

Questions and Answers

Question #1:

"Manufacturing dowel baskets in these lengths is cost-prohibitive and cannot be produced & shipped in this required deadline, due to changes of manufacturing equipment required.

These are possible with two smaller baskets installed with correct spacing per joint, see example detail below.

This example is a "10.5ft long basket w/ 8 dowels" per the RFQ, installed in a 12FT long joint, and referred to as 12 billable feet per the dowel manufacturer:

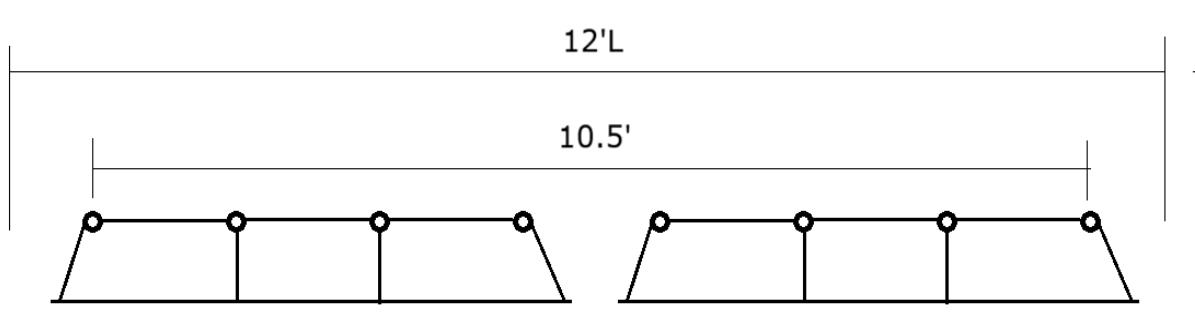

We can complete the current bid schedule provided, but please acknowledge and approve that each joint longer than 5 dowels will require an installed combination of two baskets, spaced appropriately."

Answer #1:

Providing shorter baskets that still meet the required dowel spacing is acceptable. The supplier will need to provide a replacement conversion for each basket length being substituted (i.e. 10.5' baskets replaced with x.x' baskets, etc.).

End of Questions and Answers

Signed by:

Signature: _____
0EE5FA1D9E024FD...

Date: 4/22/2026

Name: Erik Shook
Title: Procurement Specialist 2