

REFLECTIONS LAKE
TOWER



1 SITE PLAN
NTS

BBFM
Engineers, Inc.
510 L Street, Suite 200
P.O. Box 91139
Anchorage, AK 99509-1139
Phone: (907) 274-2236 Fax: (907) 274-2520

REFLECTIONS LAKE VIEWING TOWER
PALMER HAY FLATS STATE GAME REFUGE
ALASKANS FOR PALMER HAY FLATS

Revisions	
#	Date

Drawn JWC	Date 1-31-2013
Checked DLB	Job No. 211090

Sheet Contents
SITE PLAN

Drawing No.
S0.1

GENERAL NOTES

THE FOLLOWING NOTES APPLY UNLESS INDICATED OTHERWISE:

CODE:

INTERNATIONAL BUILDING CODE, 2009 EDITION.

DESIGN LIVE LOADS:

FLOORS		
UNIFORM		100 PSF
CONCENTRATED		1,000 LB

WIND		130 MPH 3-SECOND GUST
		EXPOSURE C
		BUILDING CATEGORY II, I = 1.00
		qh = 37 PSF

SEISMIC		I = 1.00, Ss = 1.50, S1 = 0.54
		SOIL SITE CLASS D
		Sds = 1.00, Sd1 = 0.54,
		SEISMIC DESIGN CATEGORY D
		BASIC SEISMIC FORCE RESISTING SYSTEM:
		ORDINARY STEEL CONCENTRICALLY
		BRACED FRAME
		Cs = 0.31, R = 3.25, OMEGA = 2
		V BASE = 2.2 K,
		EQUIVALENT LATERAL FORCE ANALYSIS

FOUNDATION PILING:

HELICAL SCREW IN PILES.

PILE CAPACITY	= 16 TONS PER PILE.
VERTICAL BATTER PILE CAPACITY	=1.5 TONS PER PILE.

PROVIDE DESIGN CRITERIA THAT ARE BEING USED TO DETERMINE PILE CAPACITY & EXPLANATION OF HOW THE PILE WILL BE INSTALLED. INDICATE DEPTH TO WHICH PILE WILL BE INSTALLED TO DEVELOP THE REQUIRED CAPACITY AND COUNTER FROST HEAVE.

SUBMIT PILE INSTALLATION RECORDS.

REINFORCED CONCRETE:

ALL CONCRETE - fc = 3,000 PSI, MAXIMUM W/C = 0.50, AIR ENTRAINMENT 6%.

REINFORCING STEEL SHALL CONFORM TO ASTM A615, GRADE 60.

CONCRETE COVER 3"

STRUCTURAL STEEL:

ALL STEEL ASTM A36, EXCEPT WIDE FLANGE SECTIONS TO BE ASTM A992, OR A572-50. FABRICATION AND ERECTION PER AISC SPECIFICATIONS. SUBMIT SHOP DRAWINGS.

WELDING PER AWS D1.1. MINIMUM SIZE WELDS 3/16" CONTINUOUS FILLET. WELDERS CERTIFIED PER AMERICAN WELDING SOCIETY FOR ROD AND POSITION. ELECTRODES SHALL BE E70XX MINIMUM, WITH MINIMUM CHARPY V-NOTCH TOUGHNESS OF 20 FT-LB AT -20 DEG F.

HIGH-STRENGTH BOLTS PER ASTM A325. BOLTED CONNECTIONS - PRETENSIONED. TENSION HIGH-STRENGTH BOLTS BY DIRECT TENSION INDICATOR METHOD USING LOAD INDICATOR DEVICES INSTALLED PER MANUFACTURER'S INSTRUCTIONS.

PROVIDE A PAINT SYSTEM FOR EXTERIOR EXPOSURE. APPLY PAINT SYSTEM IN THE SHOP TO ALL STEEL EXCEPT FOR CONTACT SURFACES IN BOLTED PARTS, OR AREAS TO BE FIELD WELDED. TOUCH UP IN THE FIELD AS REQUIRED.

STRUCTURAL SAWN LUMBER:

LUMBER VISUALLY GRADED AND STAMPED PER WWPA STANDARD GRADING RULES. MOISTURE CONTENT OF LUMBER 2" OR LESS IN THICKNESS - 19 PERCENT MAXIMUM.

STRUCTURAL LIGHT FRAMING – DOUG FIR LARCH SPECIES, NO. 1 GRADE OR BETTER.

GALVANIZED A307 BOLTS.

MISCELLANEOUS:

DRAWINGS INDICATE GENERAL AND TYPICAL DETAILS OF CONSTRUCTION. WHERE CONDITIONS ARE NOT SPECIFICALLY INDICATED BUT ARE OF SIMILAR CHARACTER TO DETAILS SHOWN, SIMILAR DETAILS OF CONSTRUCTION SHALL BE USED SUBJECT TO REVIEW AND APPROVAL BY THE STRUCTURAL ENGINEER.

SHOP DRAWINGS SHALL BE SUBMITTED AND REVIEWED PRIOR TO FABRICATION.

PROVIDE TEMPORARY ERECTION BRACING AND SHORING AS REQUIRED FOR STABILITY OF THE STRUCTURE DURING ALL PHASES OF CONSTRUCTION.

SPECIAL INSPECTIONS:

THE FOLLOWING SPECIAL INSPECTIONS SHALL BE PERFORMED BY QUALIFIED PERSONNEL EMPLOYED BY THE OWNER OR THE OWNER'S AGENT. THE OWNER OR THE OWNER'S AGENT SHALL SUBMIT INSPECTORS' RESUMES TO THE OWNER FOR APPROVAL. THE CONTRACTOR SHALL COORDINATE WORK WITH THE SPECIAL INSPECTORS.

SPECIAL INSPECTORS SHALL OBSERVE THE WORK ASSIGNED FOR CONFORMANCE WITH APPROVED DESIGN DRAWINGS AND SPECIFICATIONS. INSPECTION REPORTS SHALL BE FURNISHED TO THE OWNER AND THE ENGINEER. ALL DISCREPANCIES SHALL BE BROUGHT TO THE IMMEDIATE ATTENTION OF THE CONTRACTOR FOR CORRECTION, AND TO THE ATTENTION OF THE ENGINEER OF RECORD.

THE SPECIAL INSPECTORS SHALL SUBMIT A FINAL SIGNED REPORT STATING WHETHER THE WORK REQUIRING SPECIAL INSPECTION WAS, TO THE BEST OF THE INSPECTORS' KNOWLEDGE, IN CONFORMANCE WITH THE APPROVED PLANS AND SPECIFICATIONS AND THE APPLICABLE WORKMANSHIP PROVISIONS OF THE APPLICABLE CODES.

PROVIDE THE FOLLOWING SPECIAL INSPECTIONS PER SECTION 1704 OF THE 2009 INTERNATIONAL BUILDING CODE (IBC):

HELICAL PILE FOUNDATIONS:

SPECIAL INSPECTIONS SHALL BE PERFORMED CONTINUOUSLY DURING THE INSTALLATION OF HELICAL PILE FOUNDATIONS. THE INFORMATION RECORDED SHALL INCLUDE INSTALLATION EQUIPMENT USED, PILE DIMENSIONS, TIP ELEVATIONS, FINAL DEPTH, FINAL INSTALLATION TORQUE AND OTHER PERTINENT INSTALLATION DATA AS REQUIRED BY THE ENGINEER OF RECORD.

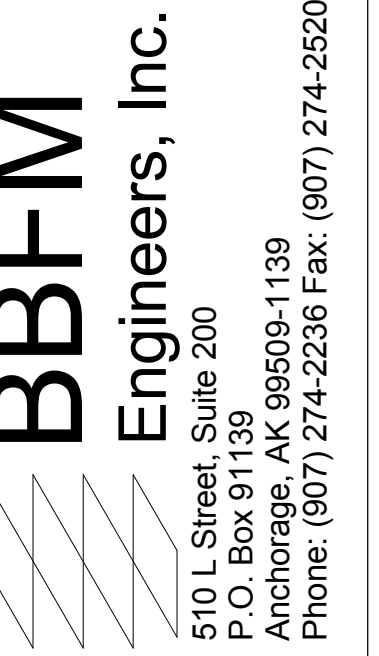

REFLECTIONS LAKE VIEWING TOWER
 PALMER HAY FLATS STATE GAME REFUGE
 ALASKANS FOR PALMER HAY FLATS

Revisions	
#	Date
2	2-19-2014

Drawn JWC	Date 1-31-2013
Checked DLB	Job No. 211090

Sheet Contents
GENERAL NOTES

Drawing No.

S0.2

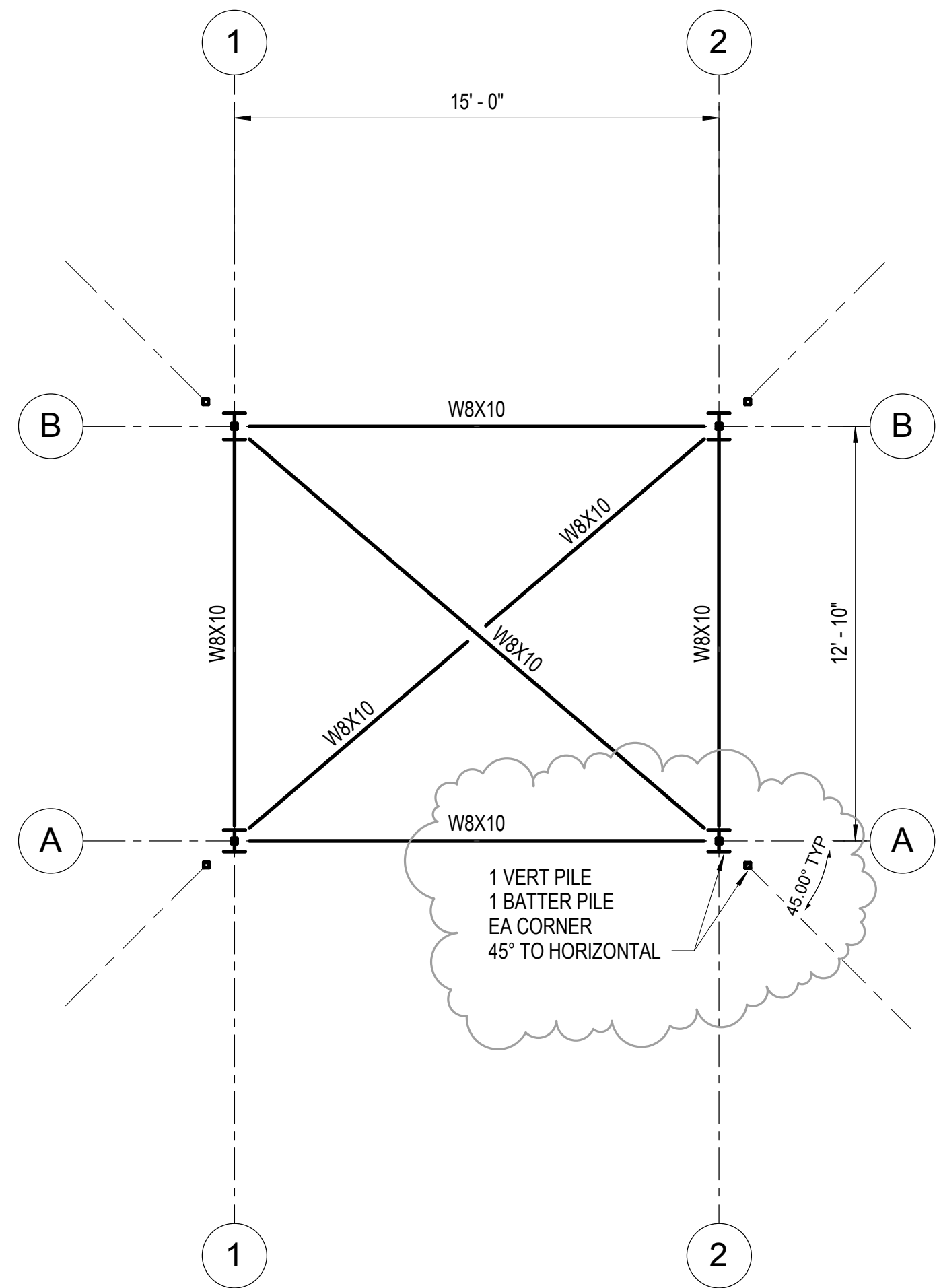

4 PILE PLAN (ADDED LEVEL OF FRAMING)
1/4" = 1'-0"

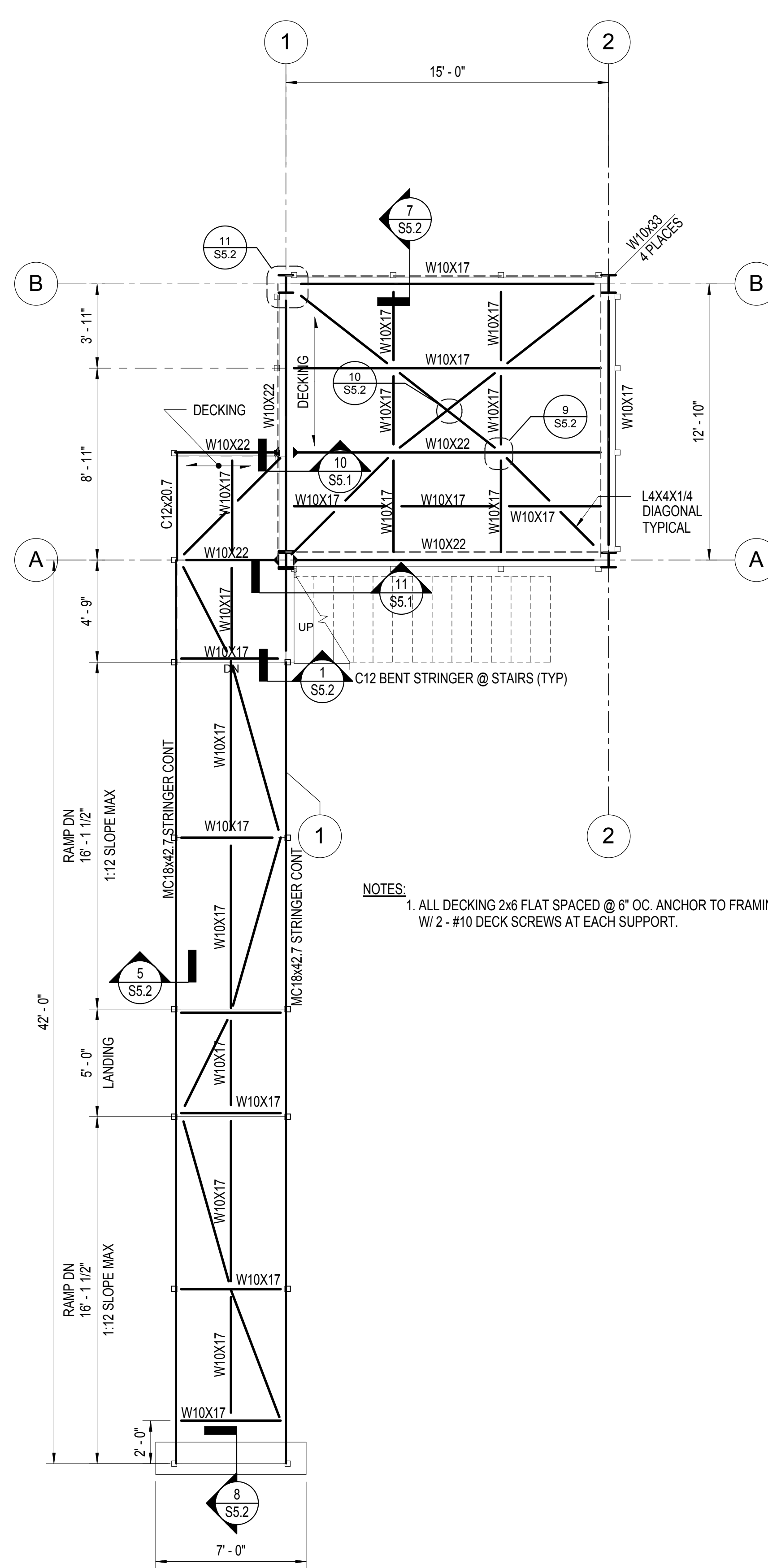

1 LOWER LEVEL FRAMING
1/4" = 1'-0"

NOTES:
1. ALL DECKING 2x6 FLAT SPACED @ 6" OC. ANCHOR TO FRAMING
W/ 2 - #10 DECK SCREWS AT EACH SUPPORT.

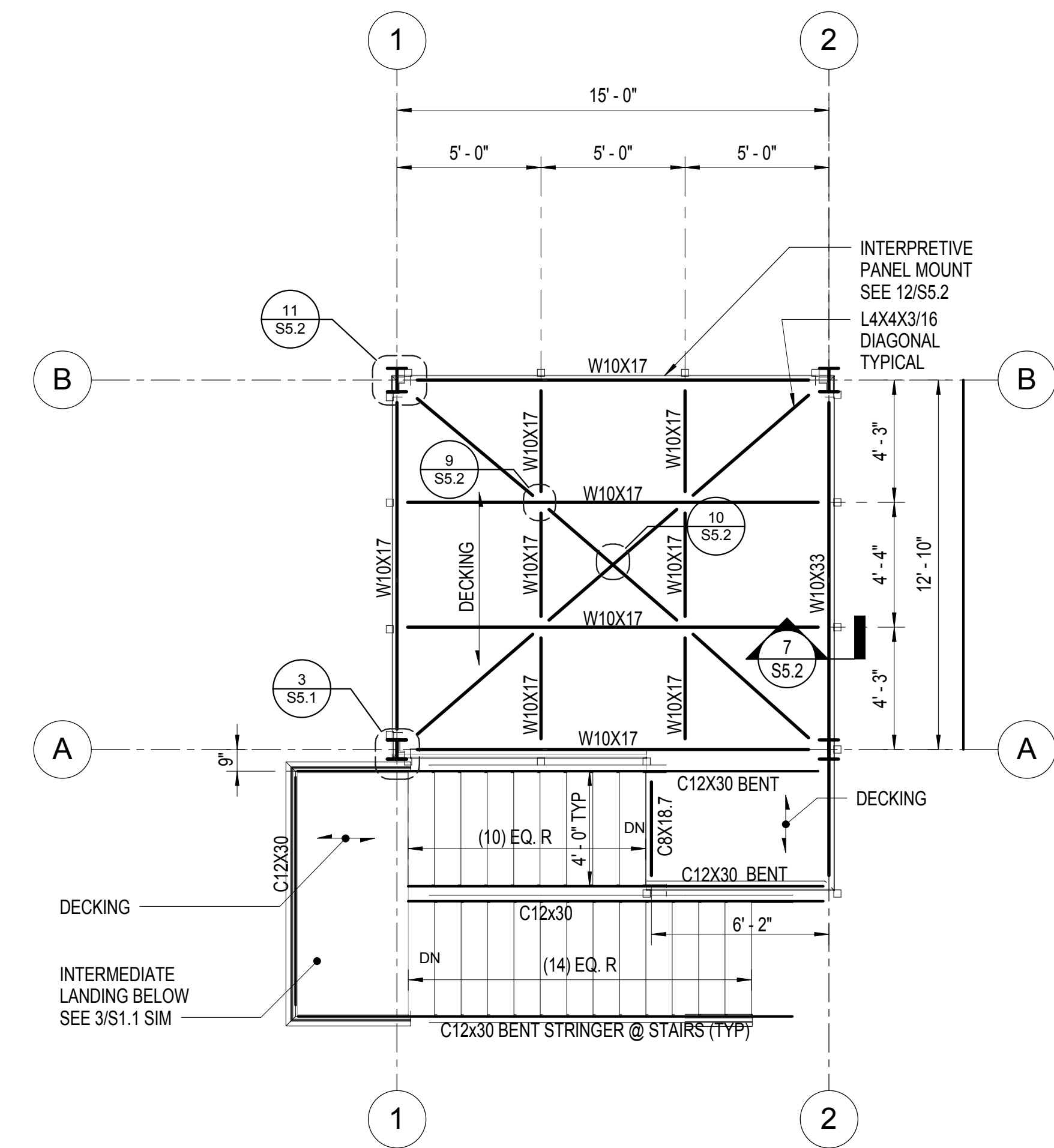

2 UPPER LEVEL FRAMING
1/4" = 1'-0"

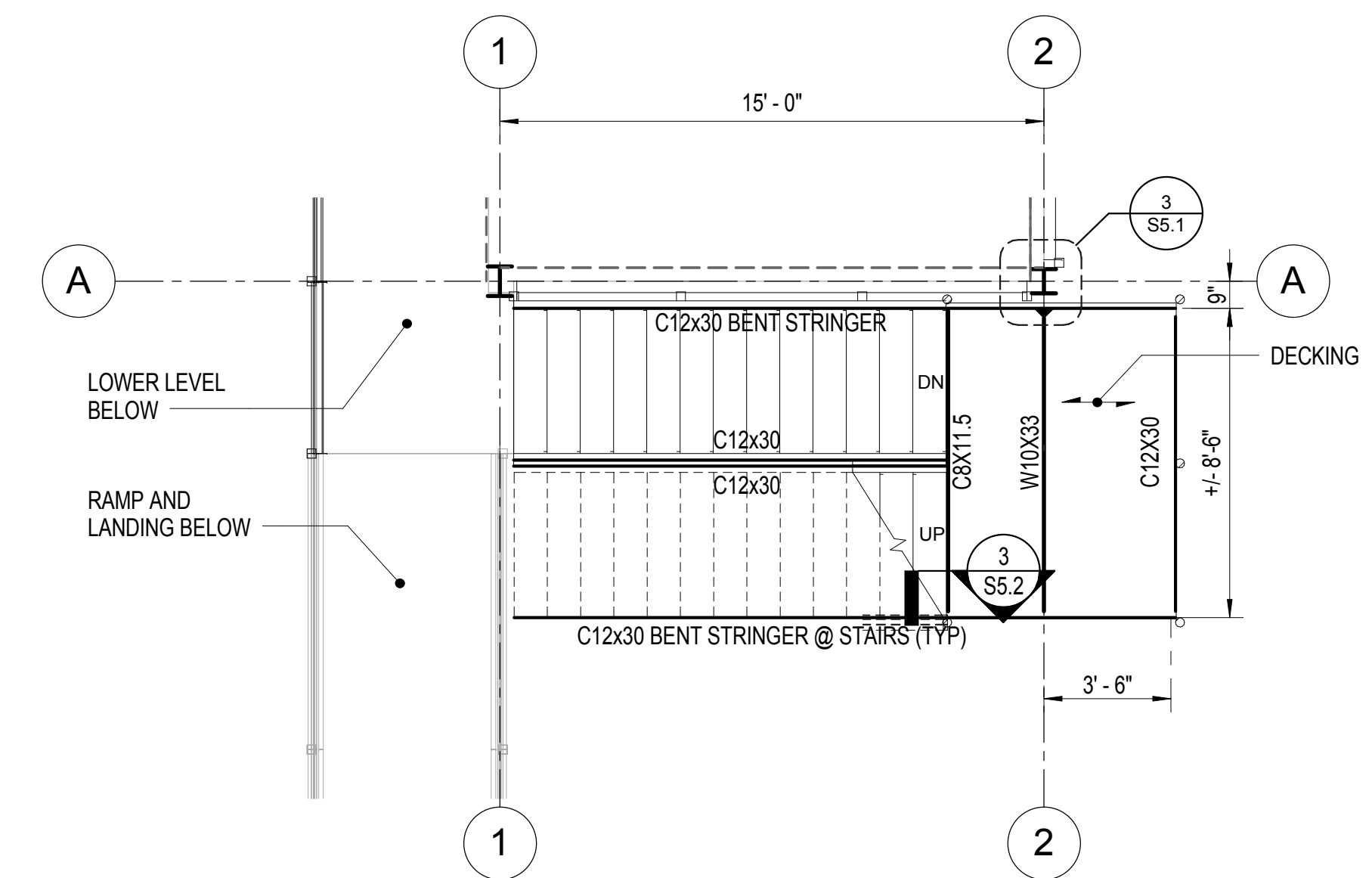

3 INTERMEDIATE LANDING (OPPOSITE LANDING SIMILAR)
1/4" = 1'-0"

Revisions	
#	Date
1	2-6-2014
2	2-19-2014

Drawn	Date
CMS	1-31-2013
Checked	Job No.
DLB	211090

Sheet Contents
FRAMING PLANS

Drawing No.
S1.1

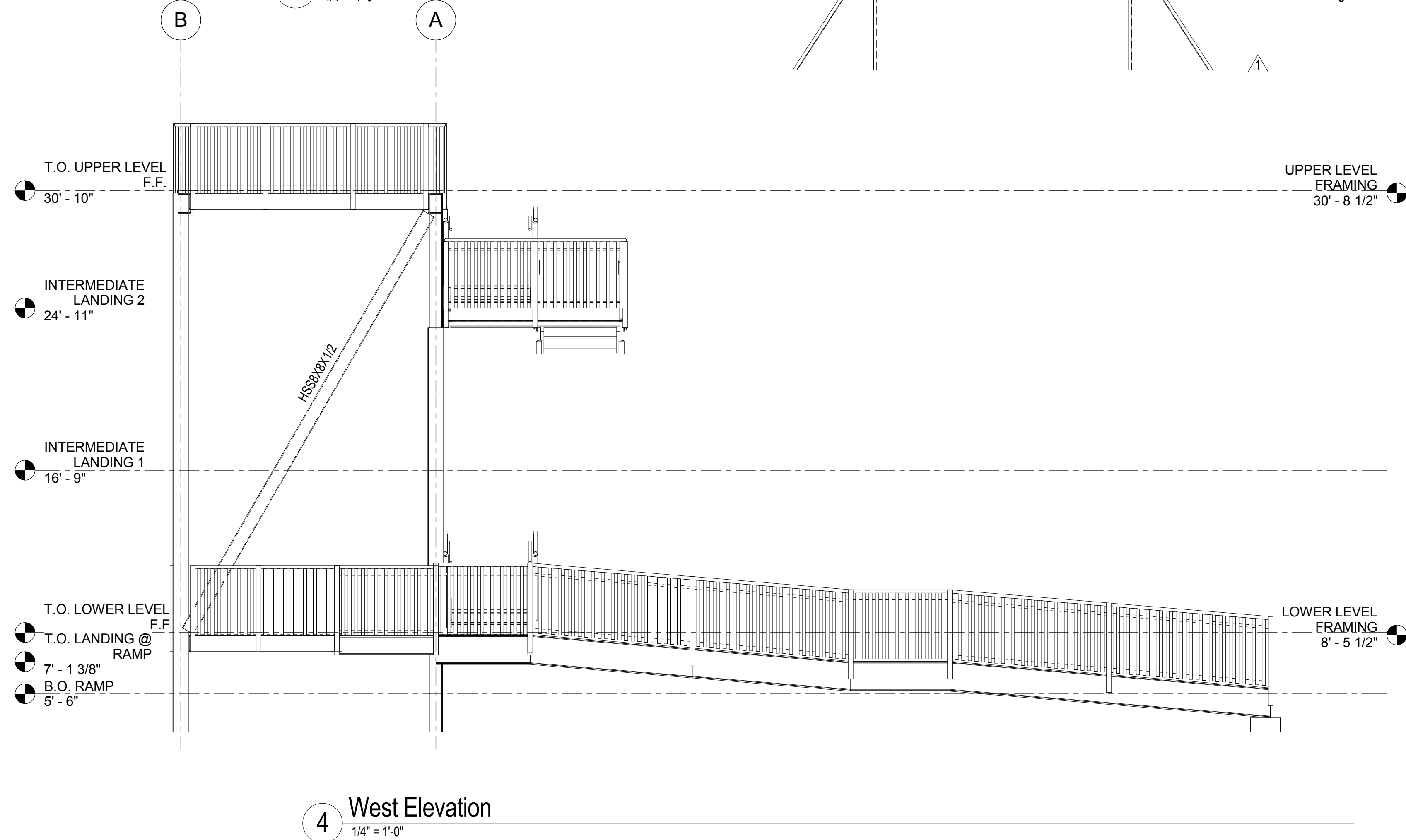
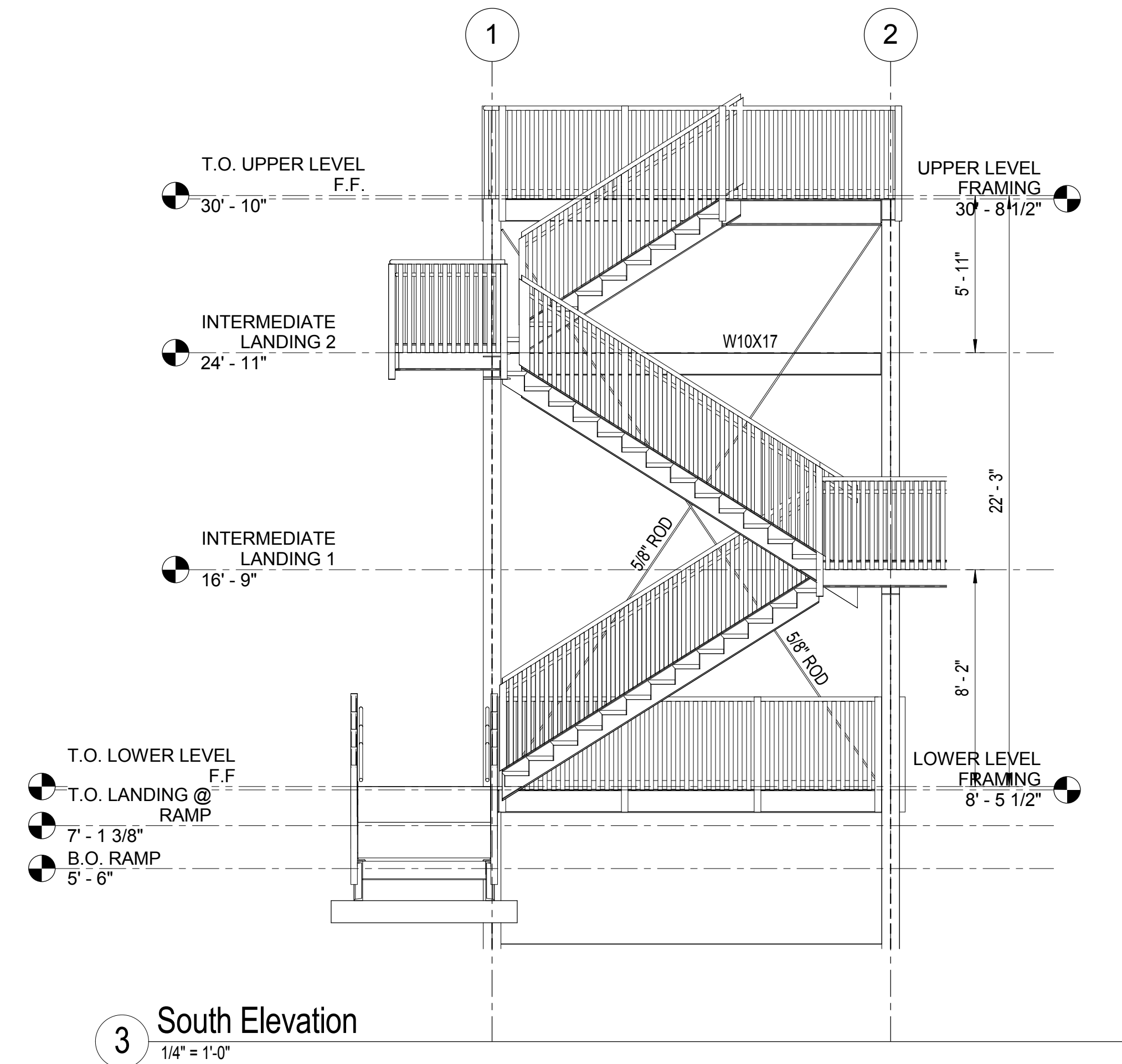
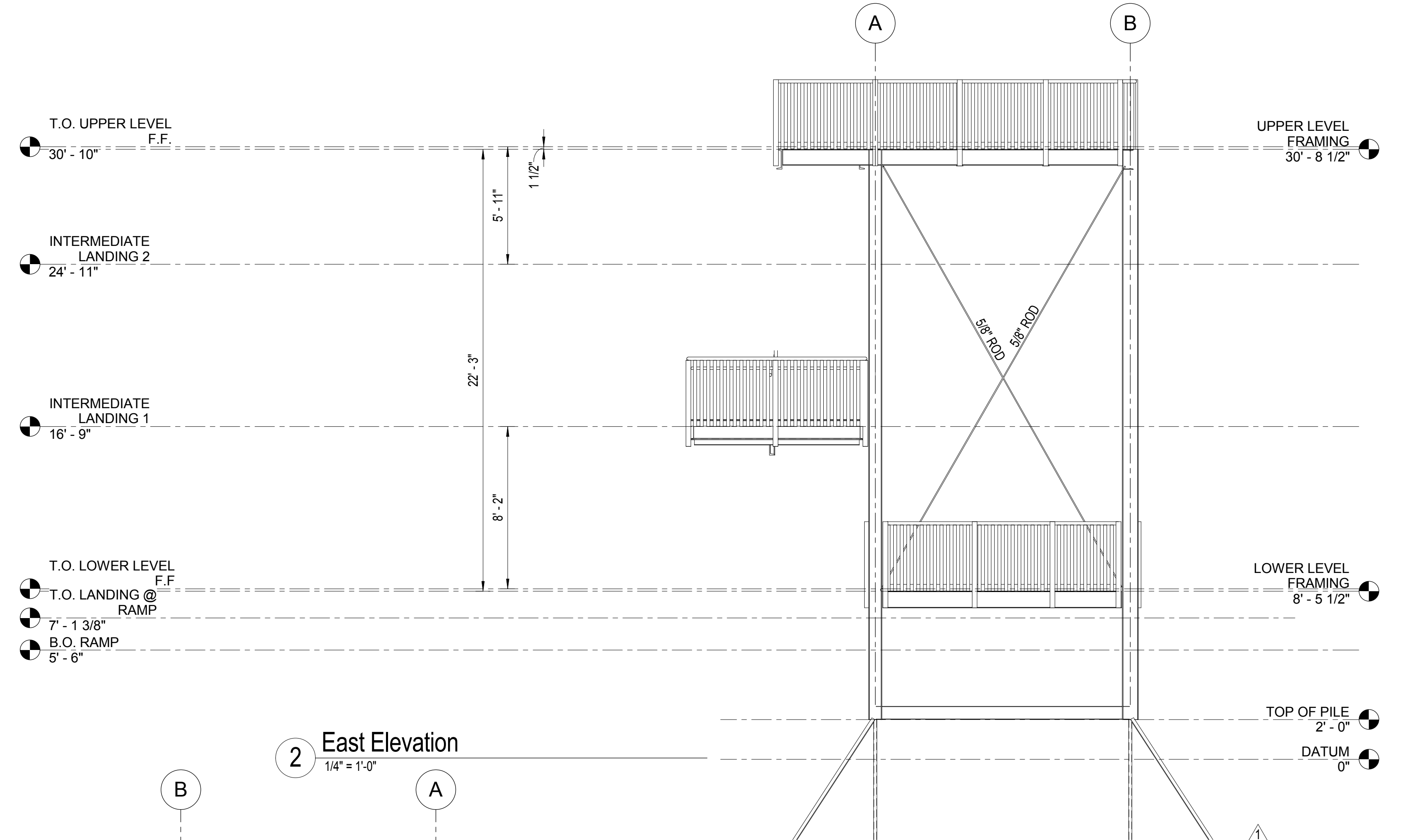
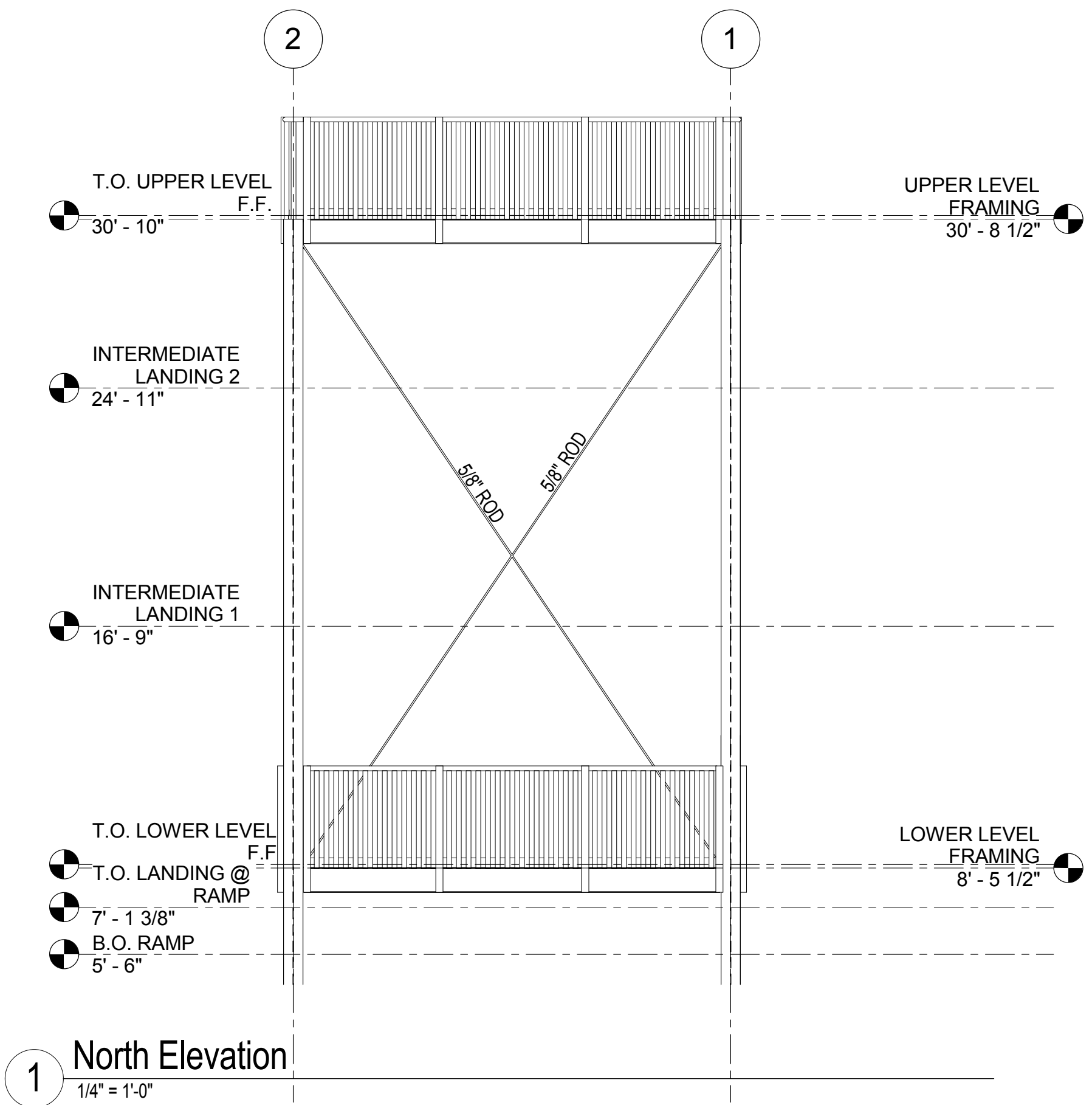

Revisions	
#	Date
1	2-6-2014

Drawn	CMS	Date	1-31-2013
Checked	DLB	Job No.	211090

Sheet Contents
ELEVATIONS

Drawing No.
S2.1

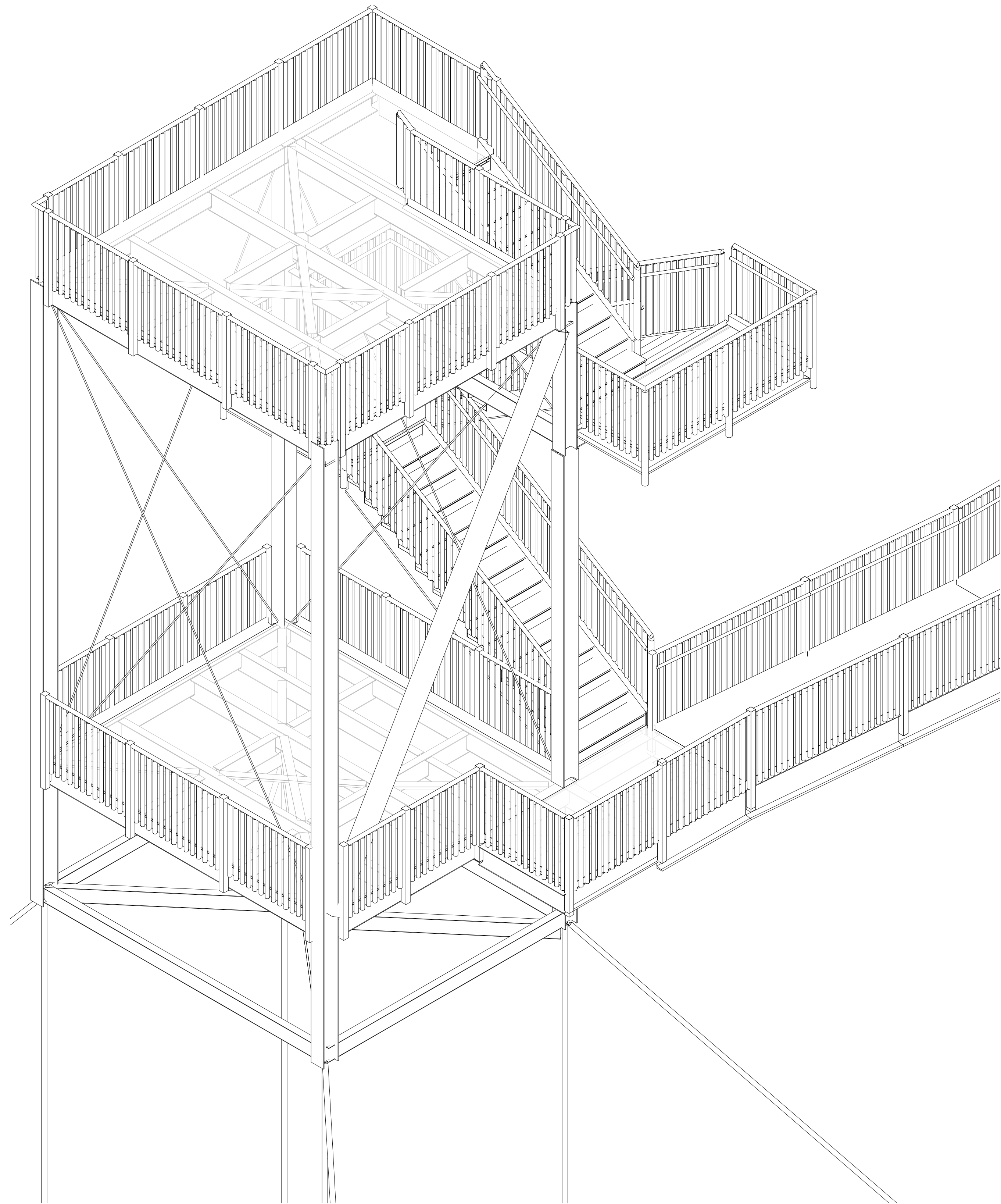

1 SW ISOMETRIC
NTS

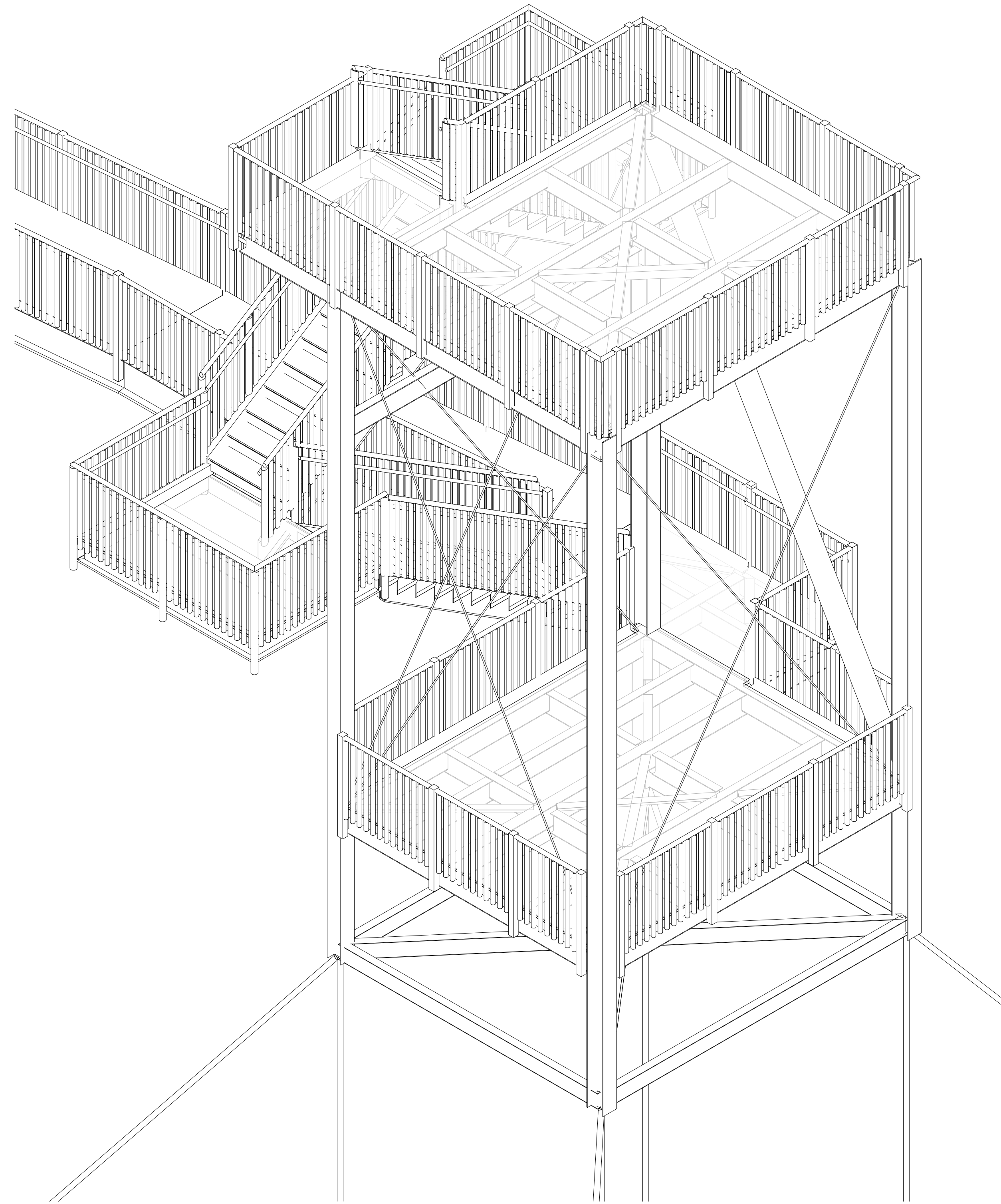

2 NE ISOMETRIC
NTS

REFLECTIONS LAKE VIEWING TOWER
PALMER HAY FLATS STATE GAME REFUGE
ALASKANS FOR PALMER HAY FLATS

Revisions	
#	Date

Drawn	Date
CMS	1-31-2013
Checked	Job No.
DLB	211090

Sheet Contents
ISOMETRIC
ELEVATIONS

Drawing No.
S2.2

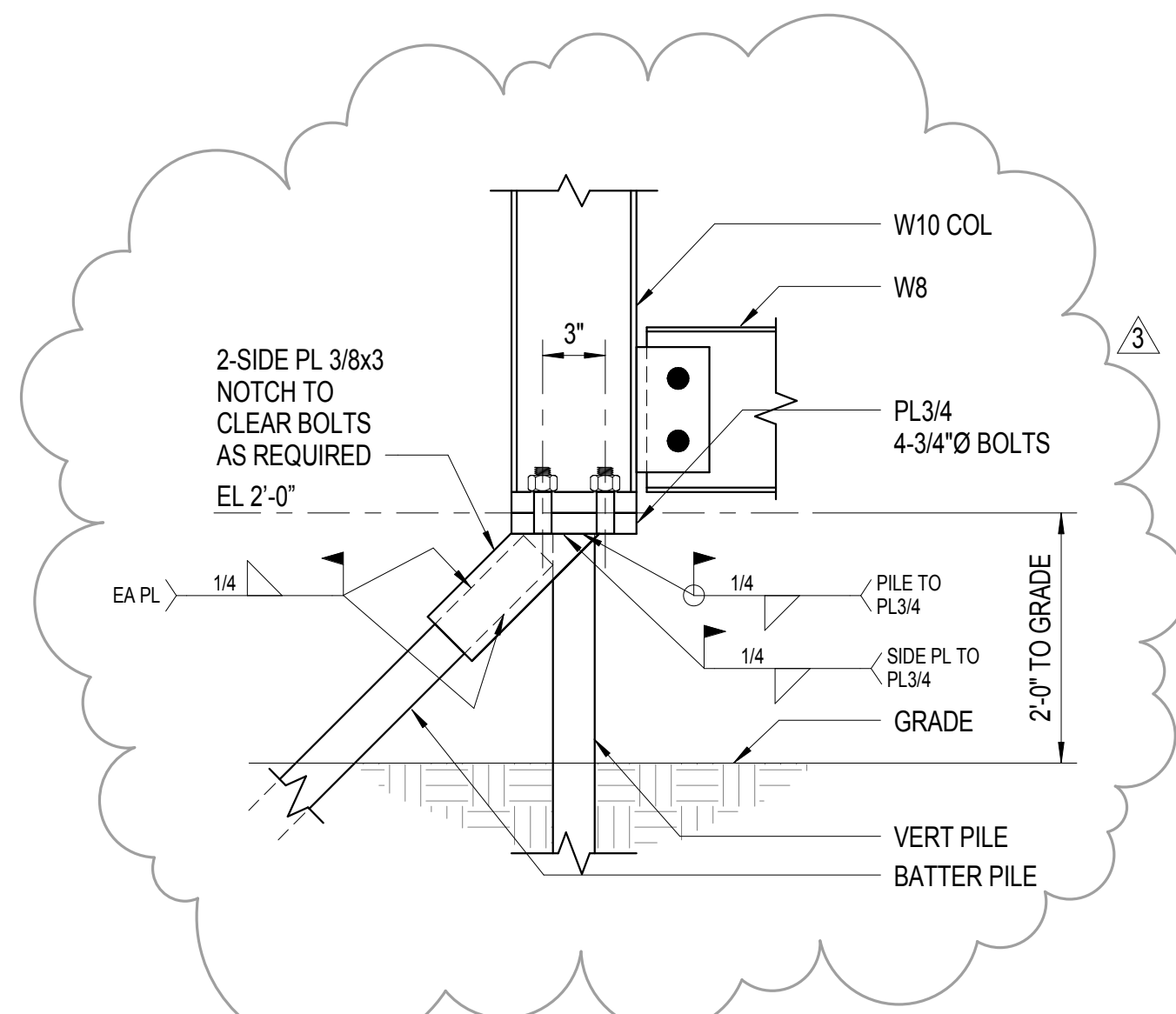

1 W COL TO PILE
1 1/2" = 1'-0"

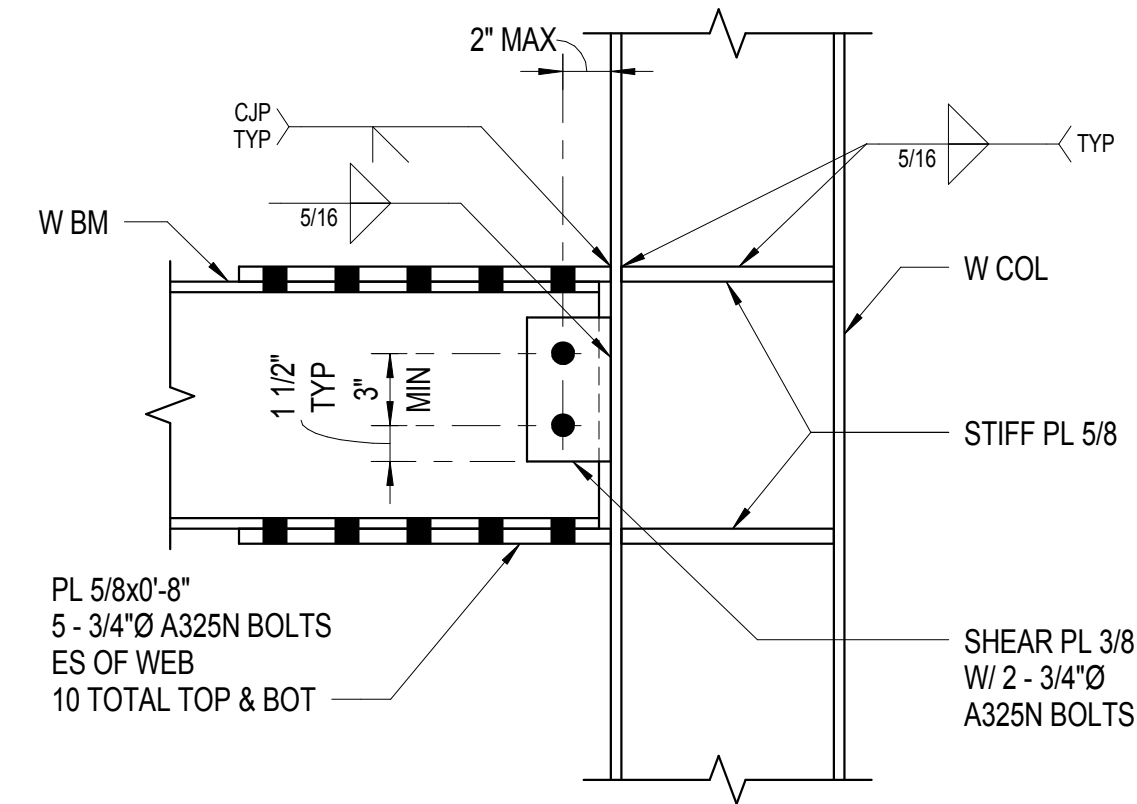

NOTE: MATCH TO FIT W BM IN SHOP OF PROVIDE SHIMS TO PROVIDE CONSTRUCTION TOLERANCE.

3 CANTILEVERED W BM TO W COL
1 1/2" = 1'-0"

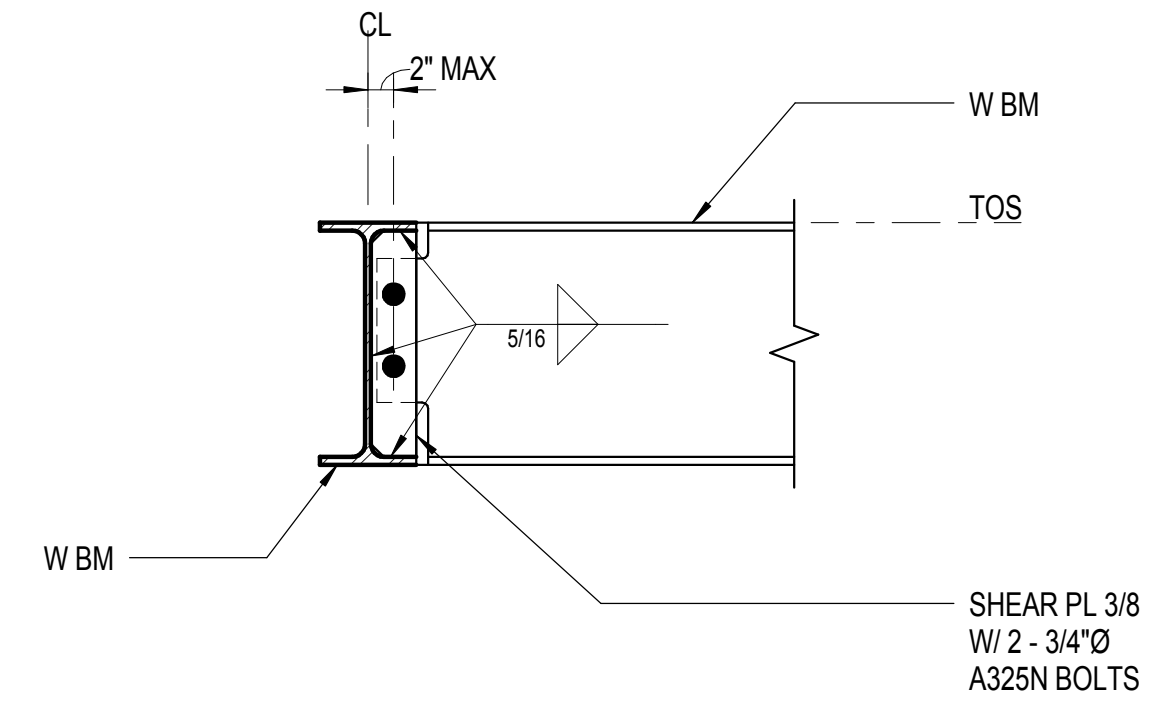

4 BEAM TO BEAM
1 1/2" = 1'-0"

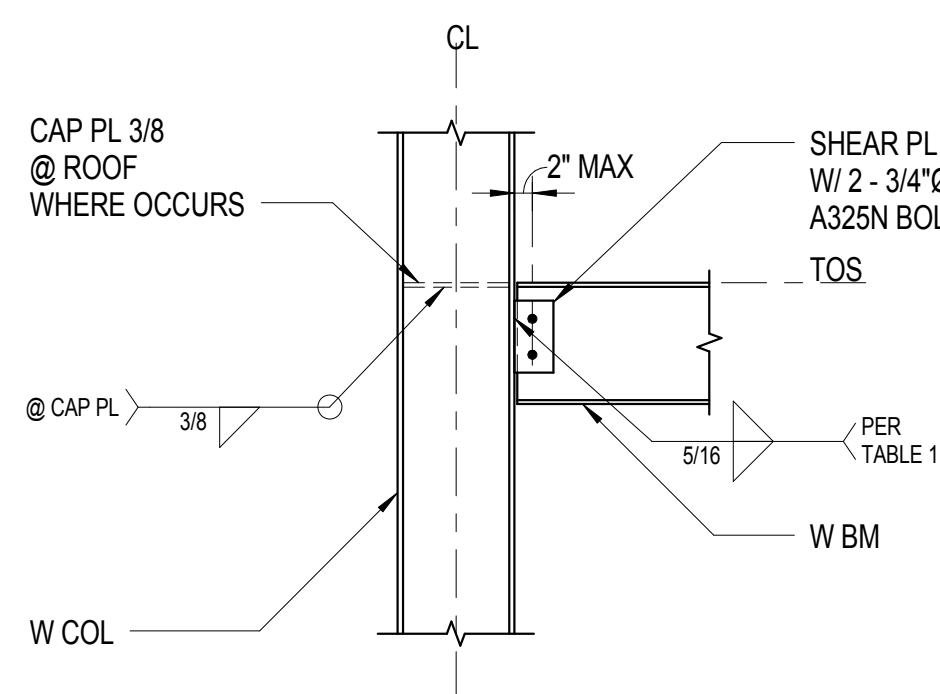

5 BM TO COL FLANGE
3/4" = 1'-0"

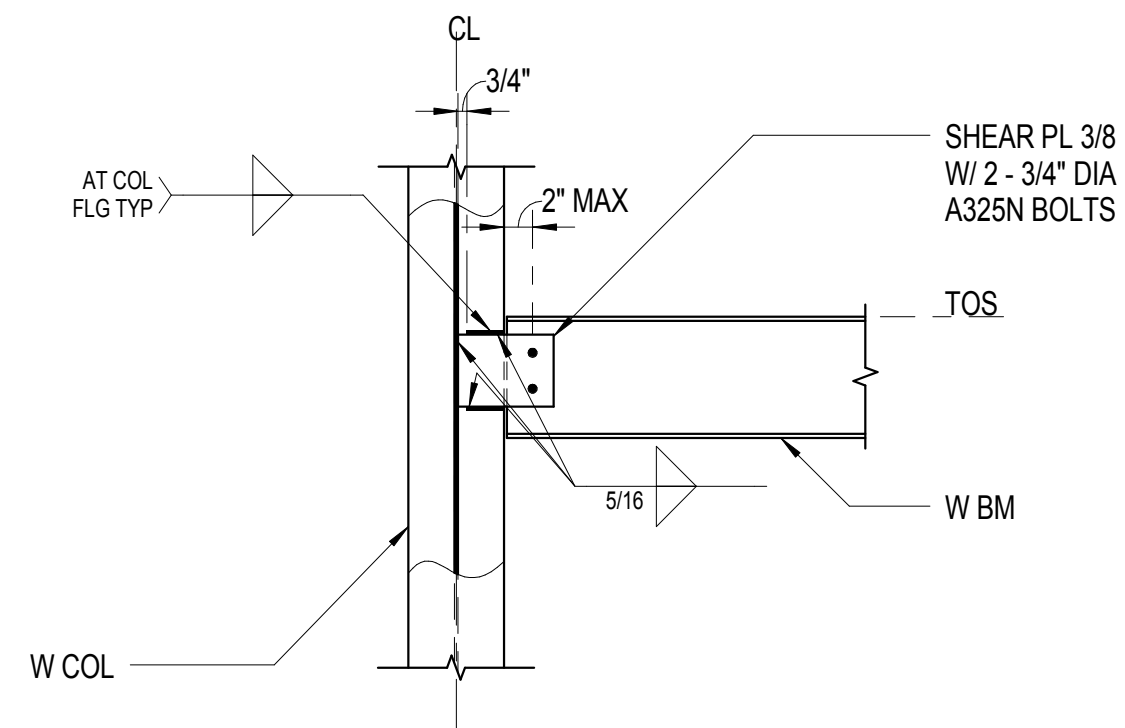

NOTE: OMIT TOP STIFFENER PLATES AT TOP OF COLUMN AND USE CAP PLATE 3/8.

6 BM TO COL WEB
3/4" = 1'-0"

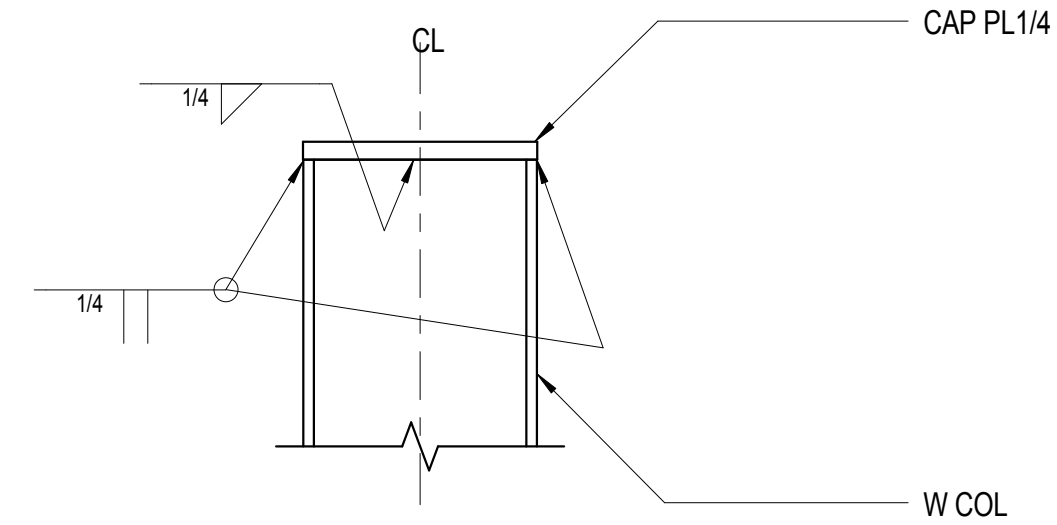

7 W COL CAP
1 1/2" = 1'-0"

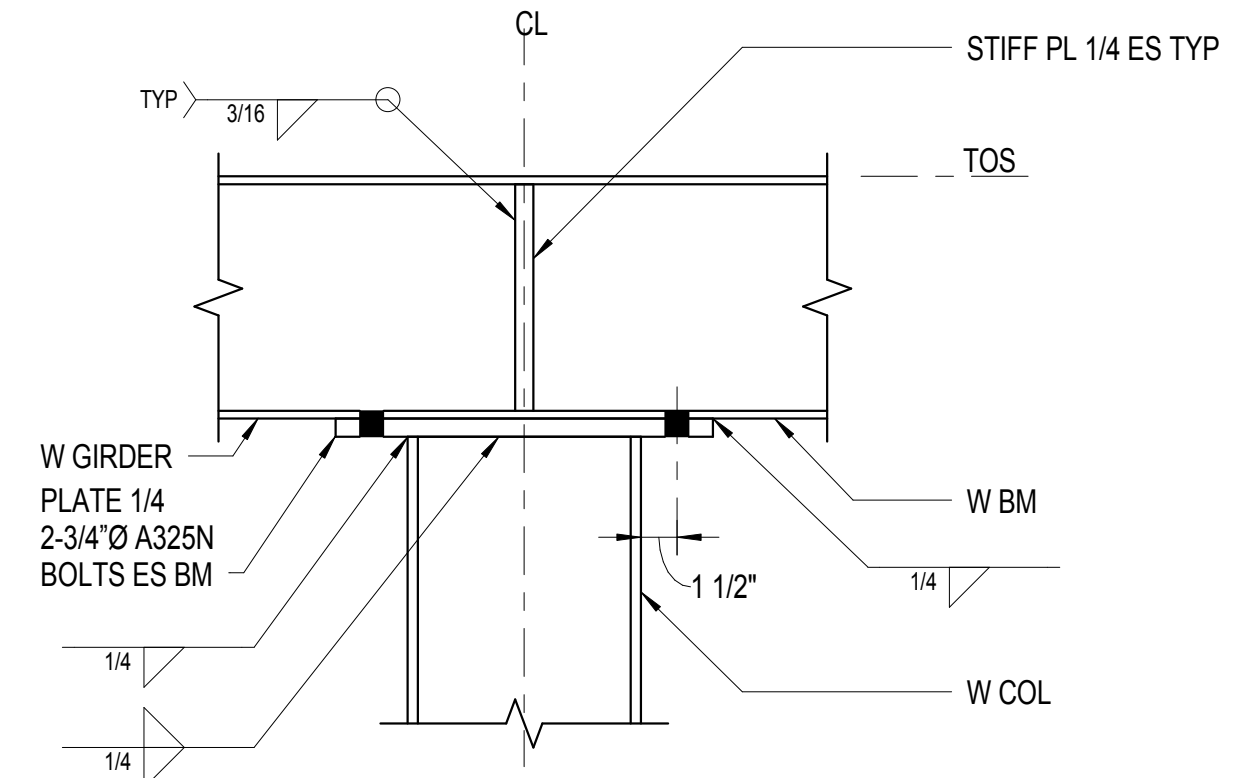

8 W BM TO W COL
1 1/2" = 1'-0"

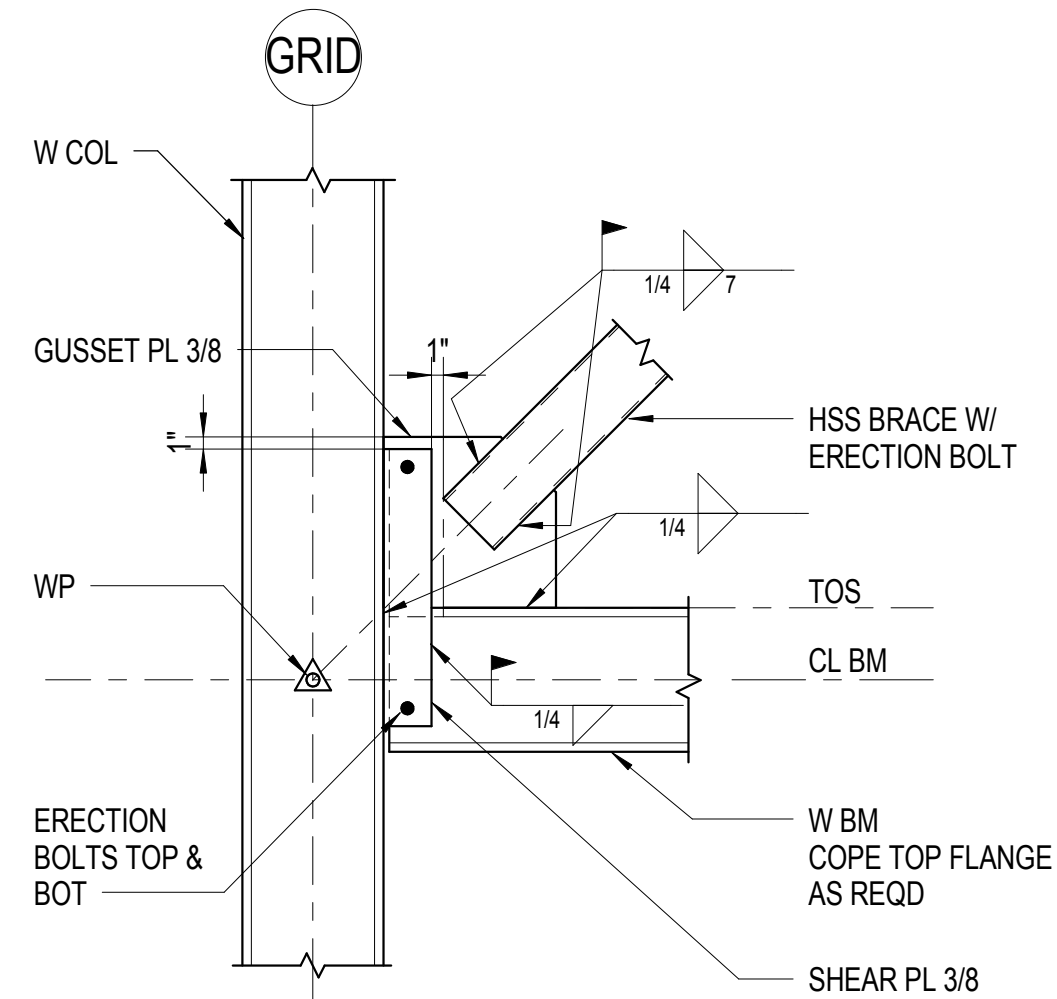

9 HSS BRACE TO W COL
3/4" = 1'-0"

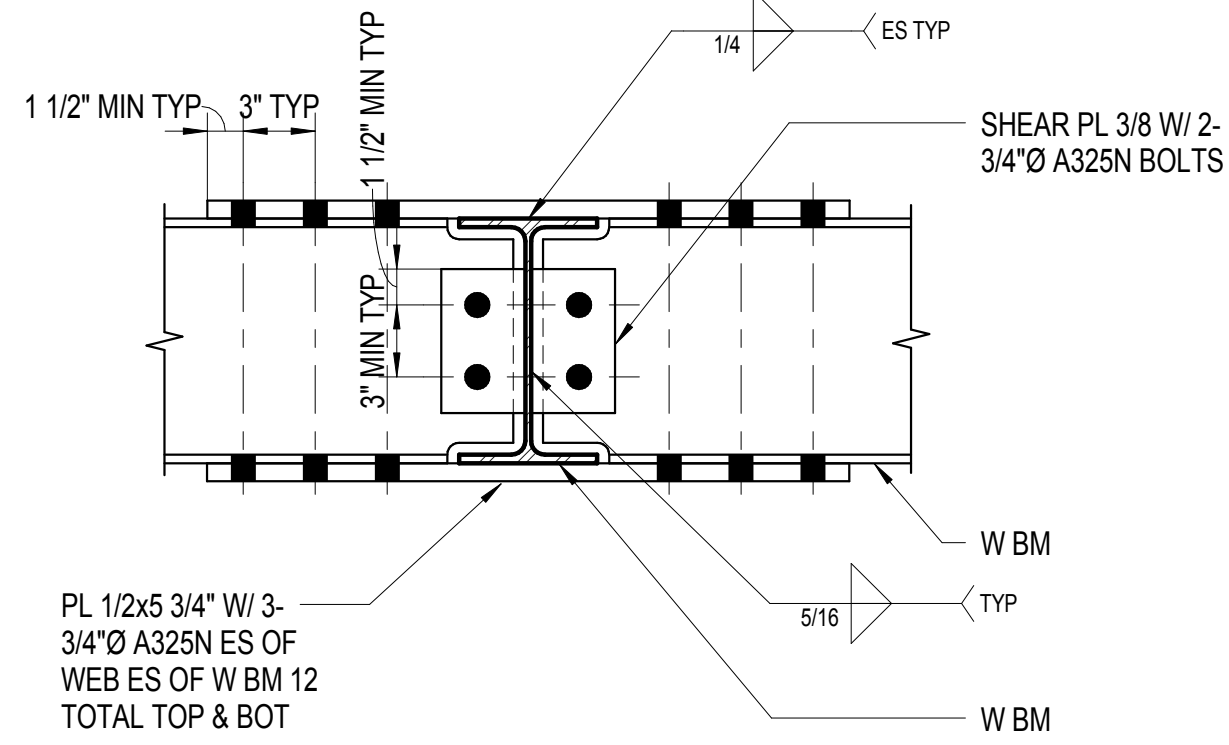

10 W BM CANTILEVER
1 1/2" = 1'-0"

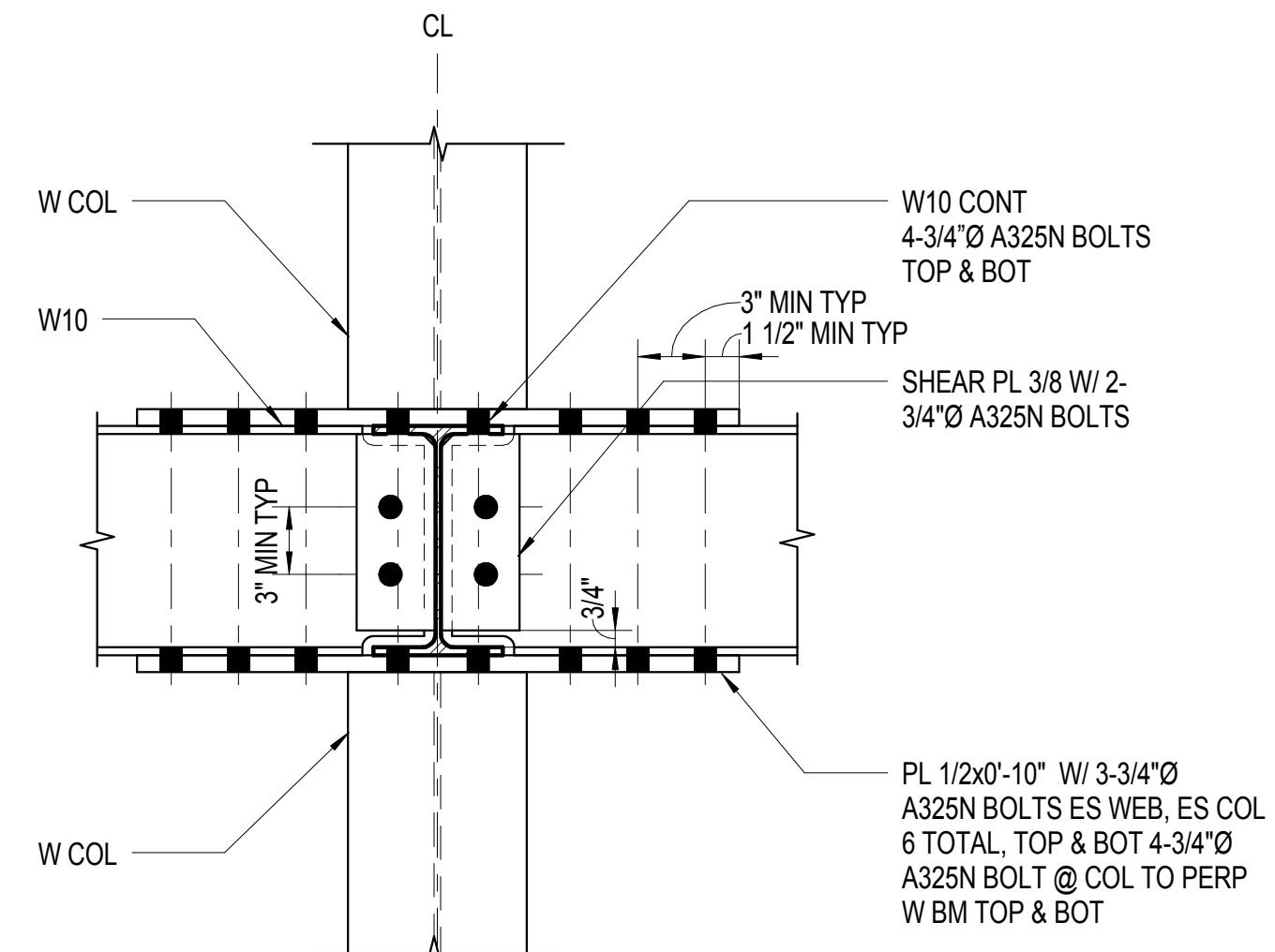

NOTE: FIT CONNECTION IN SHOP PRIOR TO PLACEMENT IN THE FIELD

11 W BM CANTILEVER CONN
1 1/2" = 1'-0"

Revisions	
#	Date
1	2-6-2014
3	2-4-2015

Drawn	Date
CMS	1-31-2013
Checked	Job No.
DLB	211090

Sheet Contents
DETAILS

Drawing No.
S5.1

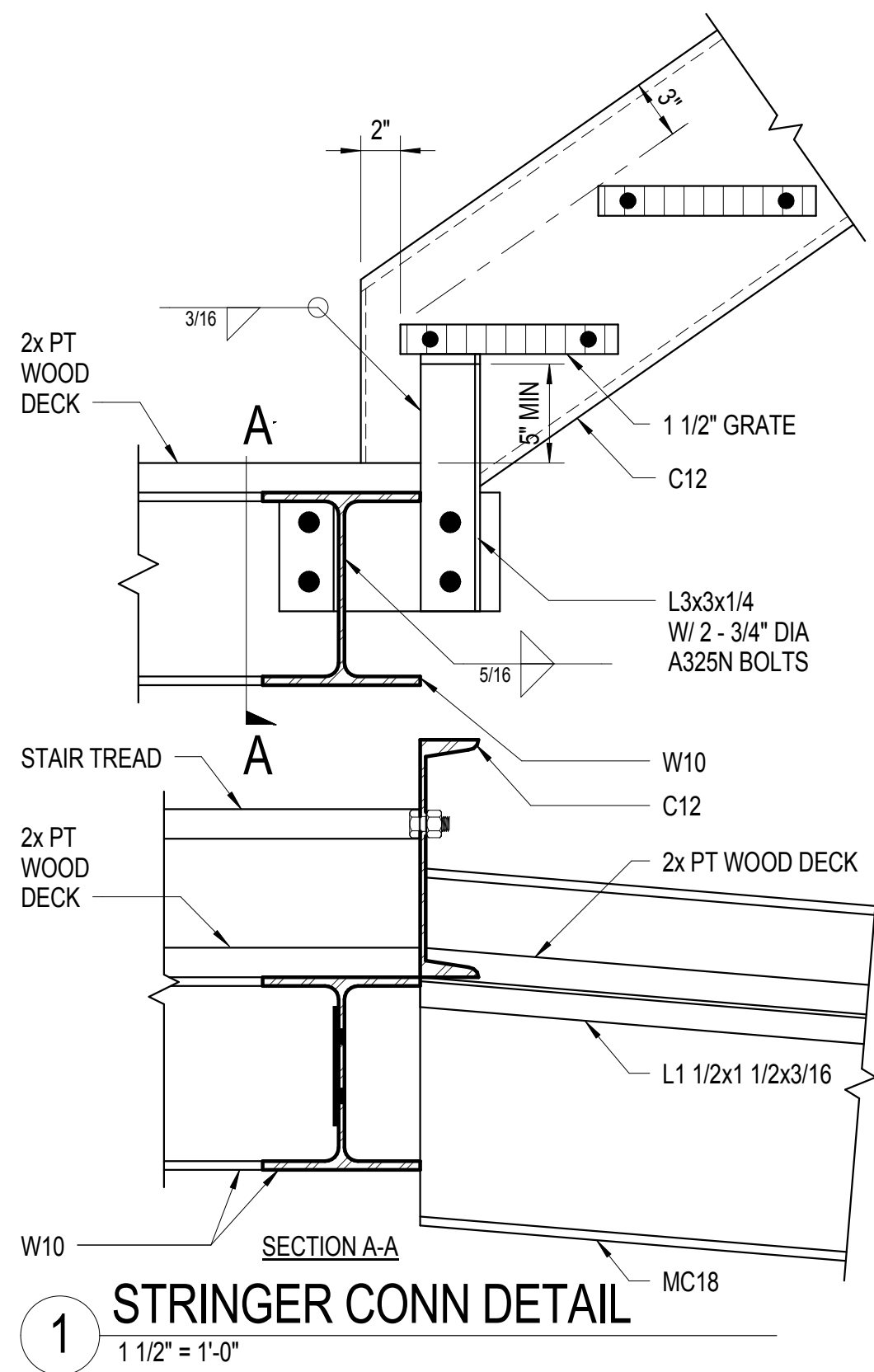

1 STRINGER CONN DETAIL
1 1/2" = 1'-0"

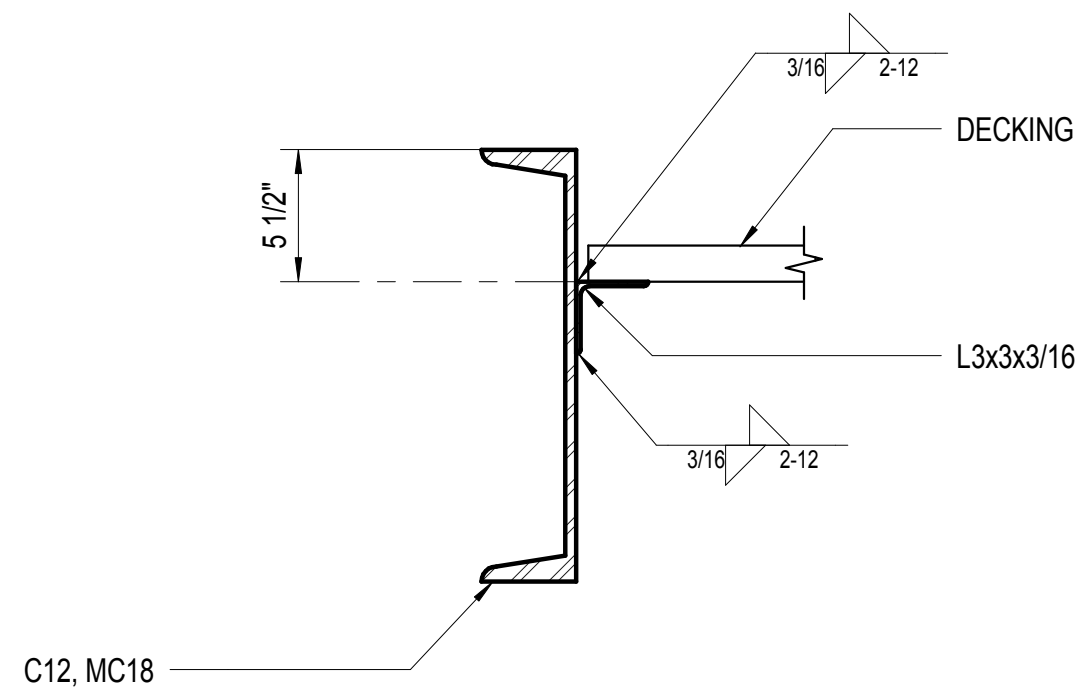

5 DECK TO MC & C
1 1/2" = 1'-0"

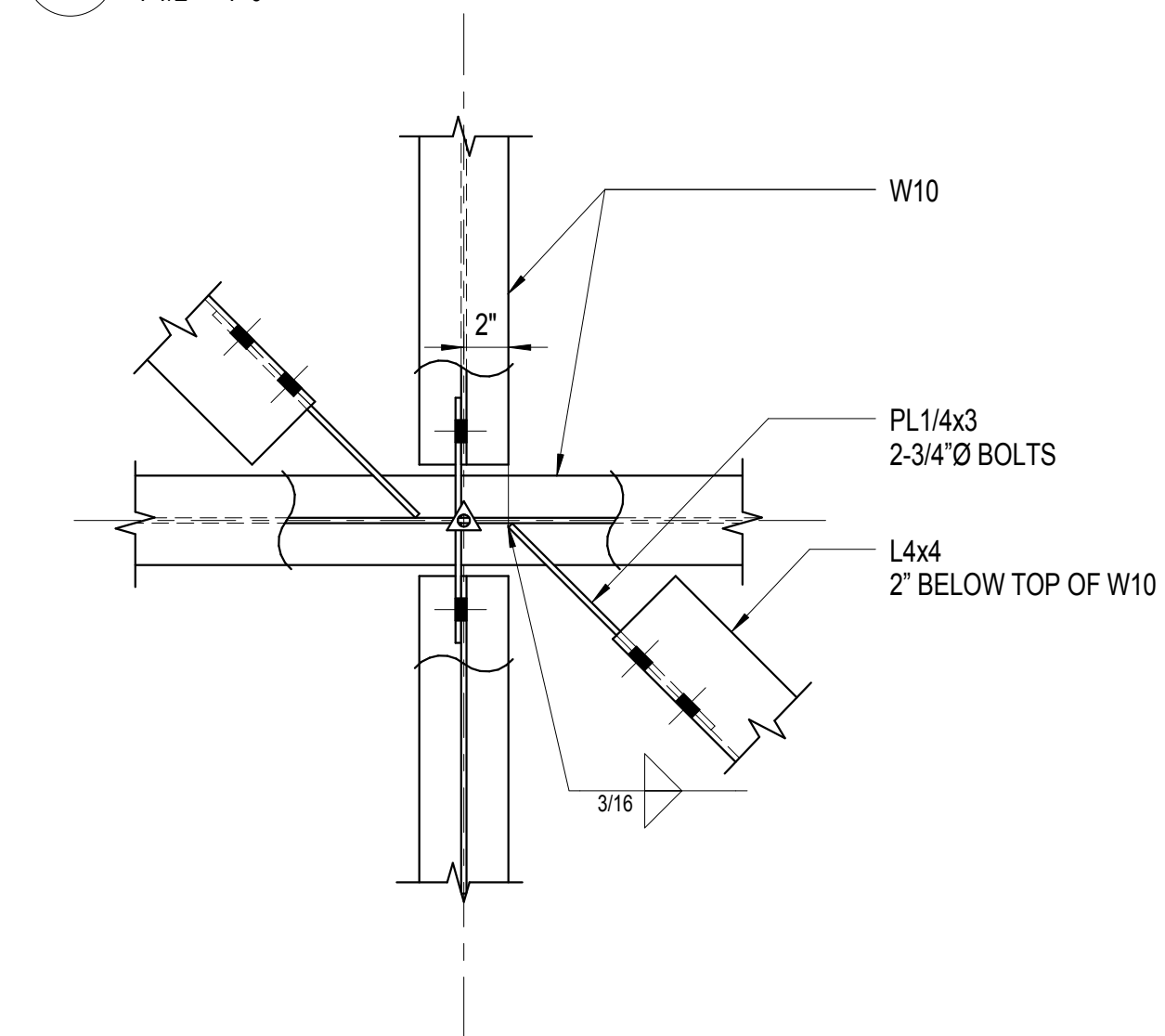

9 BRACE CONN
1 1/2" = 1'-0"

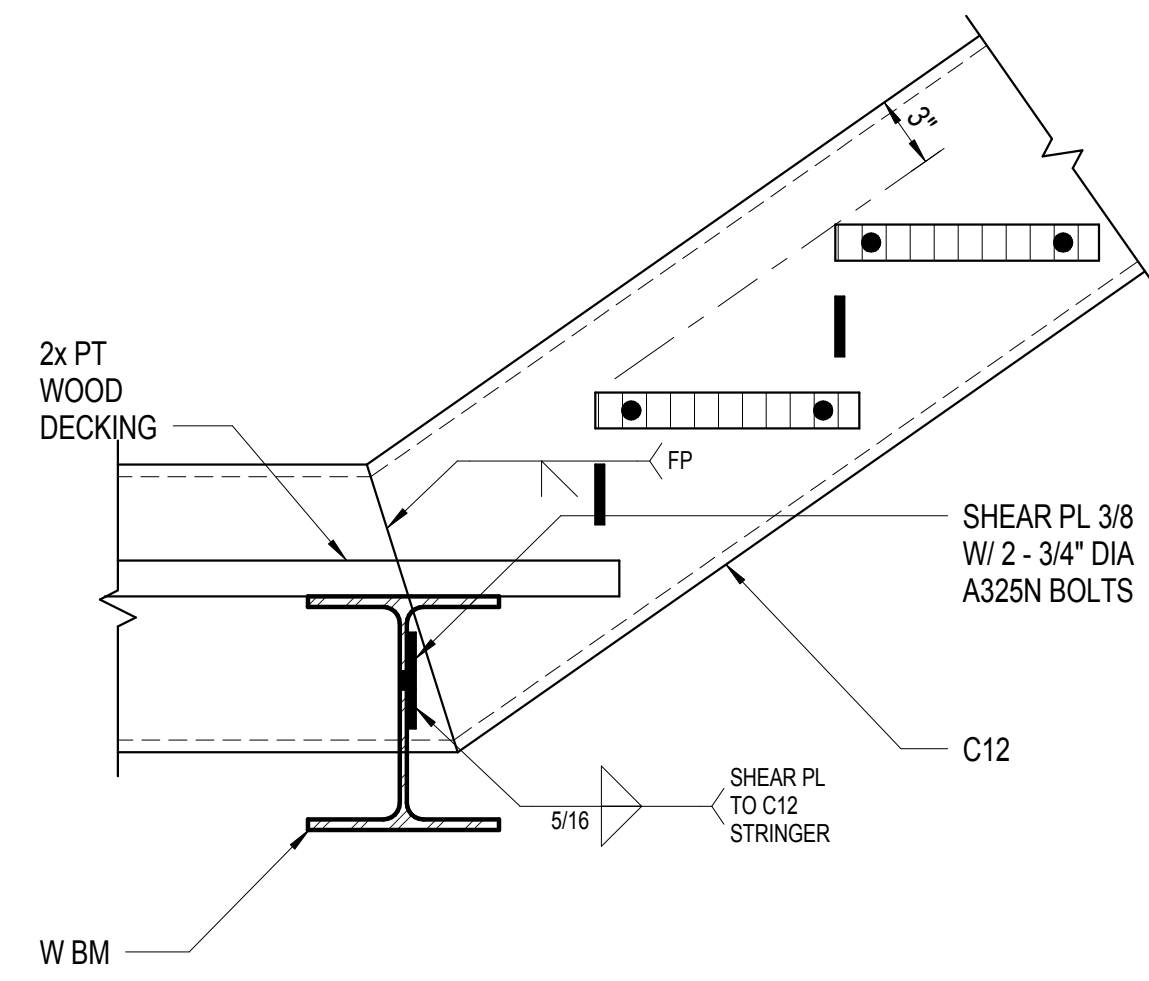

2 BENT STRINGER
1 1/2" = 1'-0"

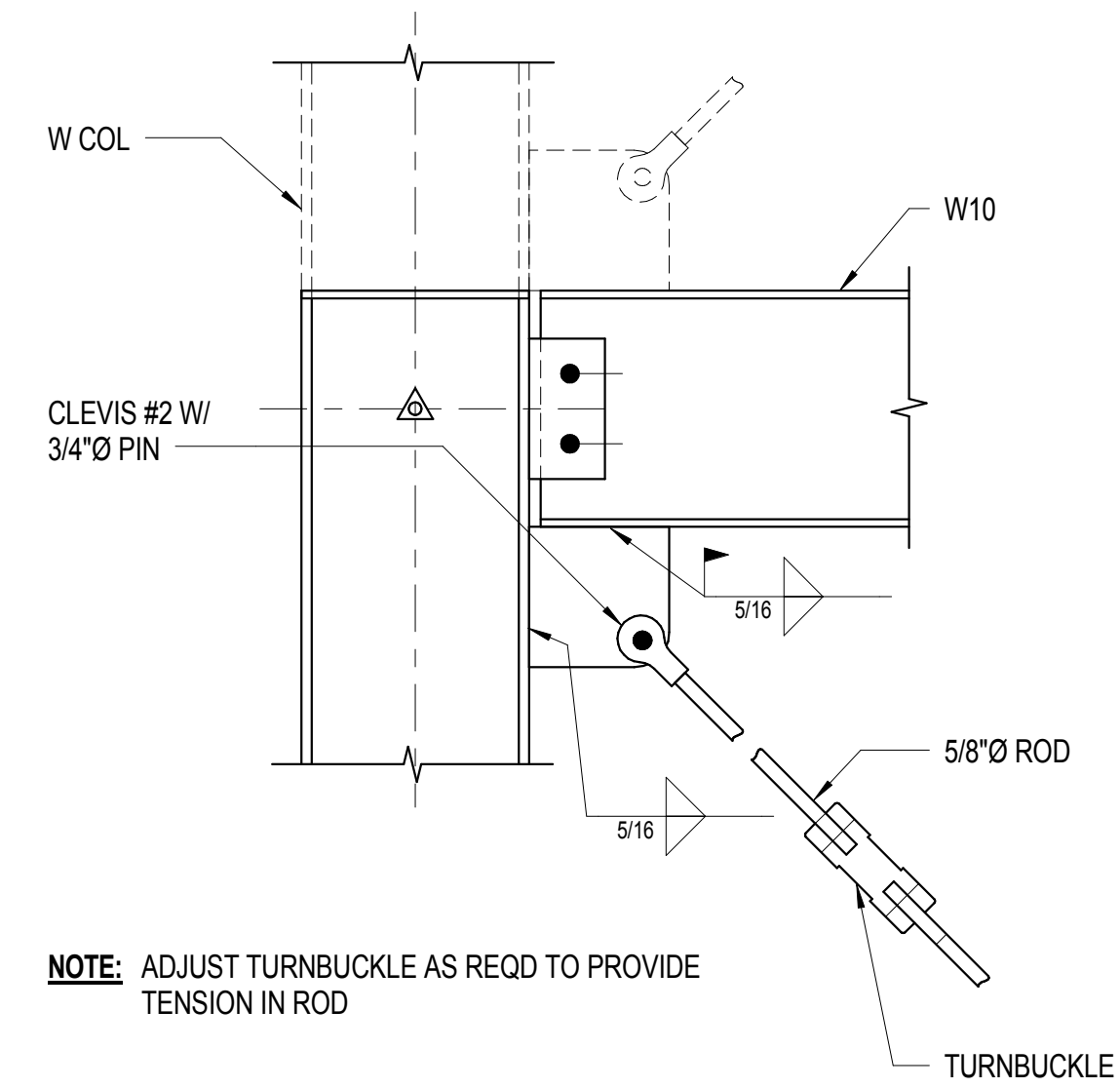

6 ROD BRACING DETAIL
1 1/2" = 1'-0"

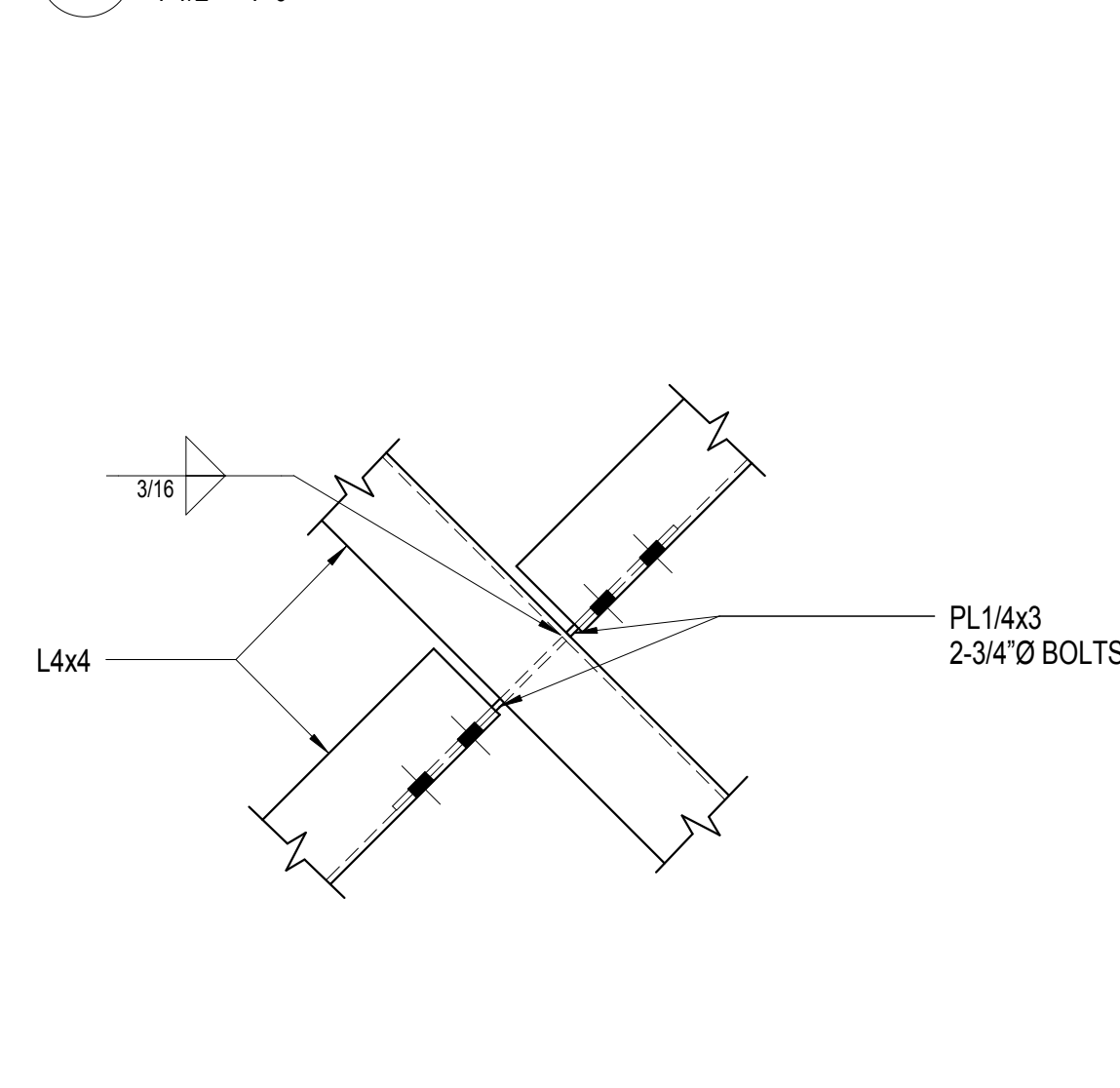

10 BRACE CONN
1 1/2" = 1'-0"

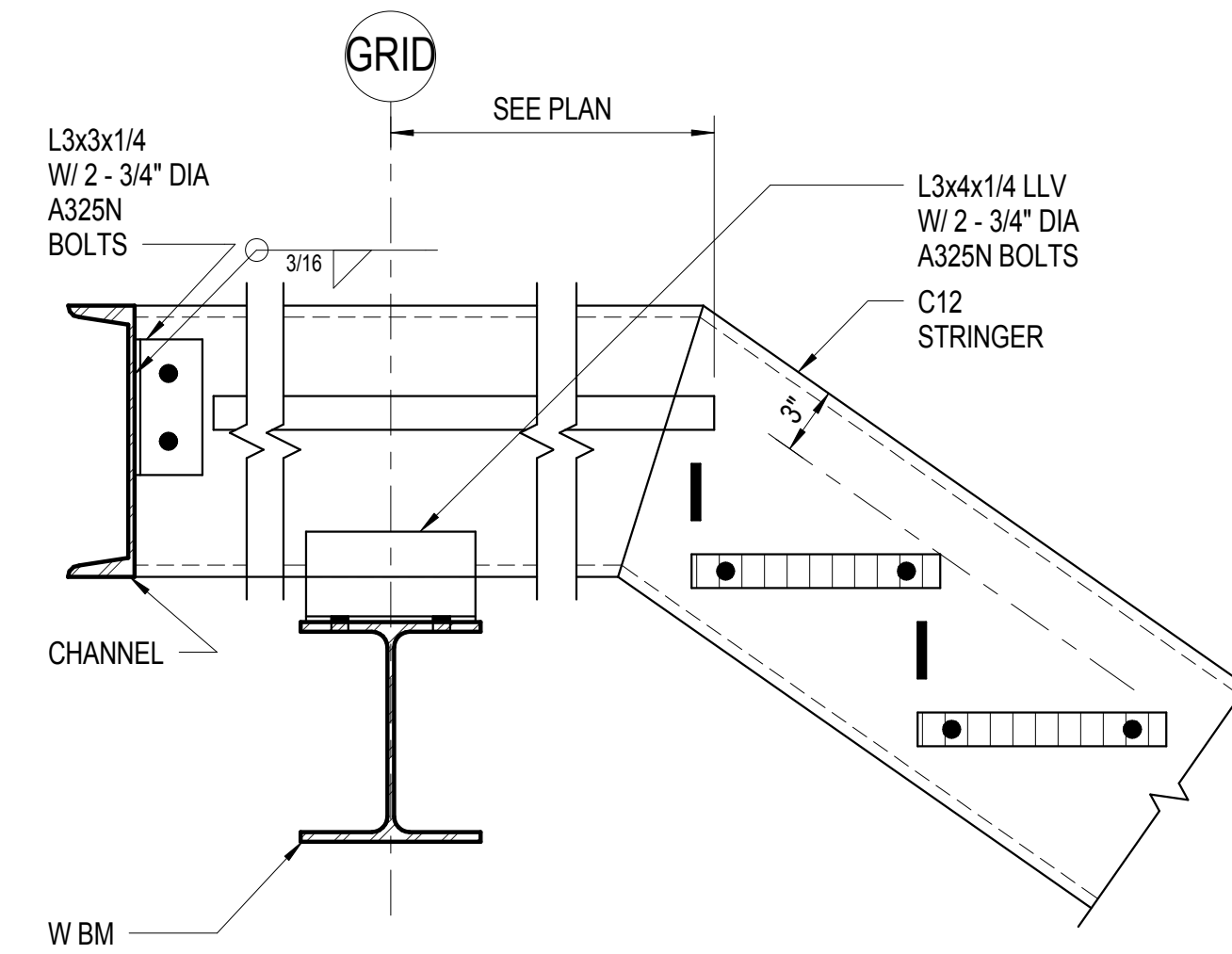

3 C12 TO W BM
1 1/2" = 1'-0"

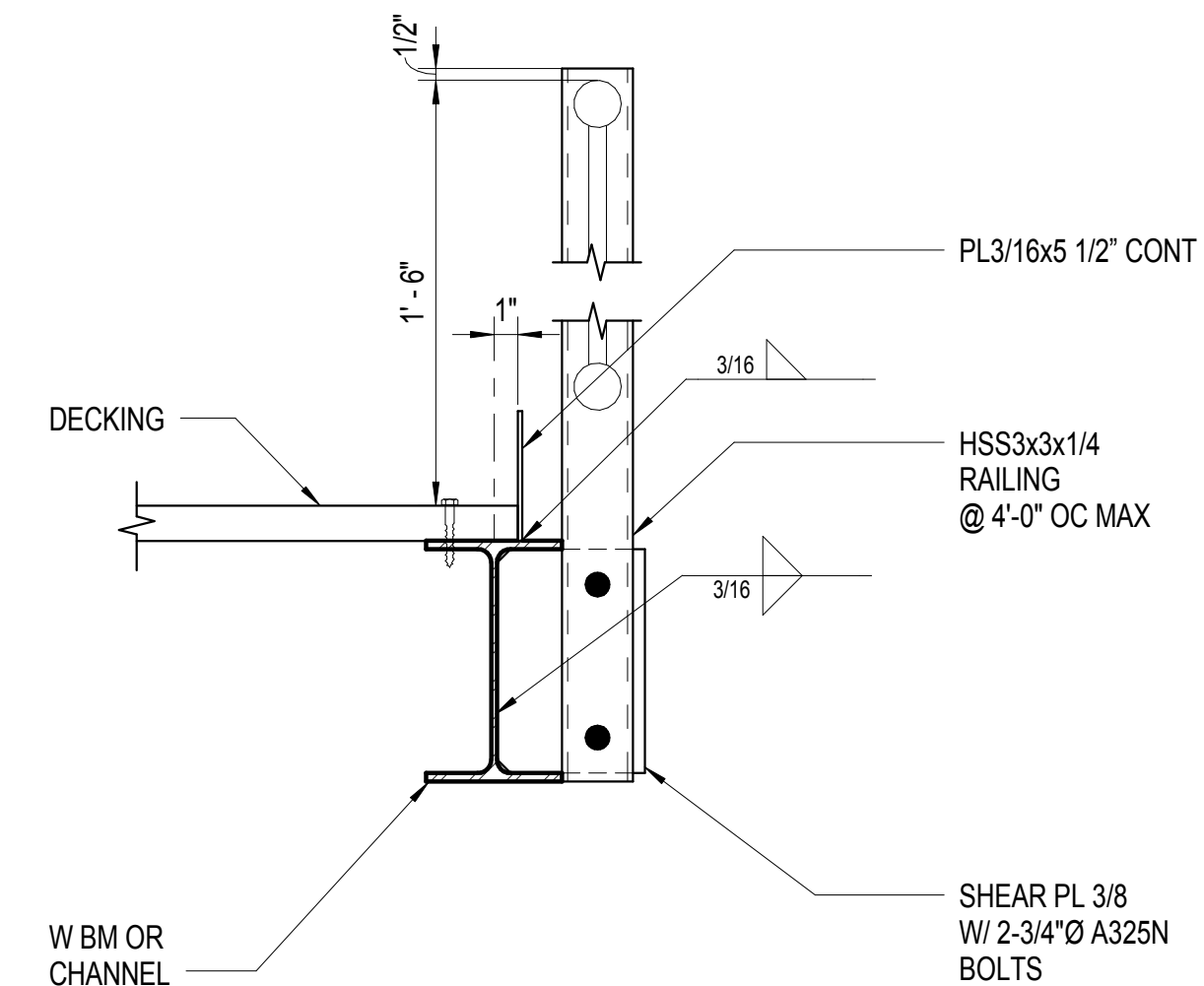

7 RAILING CONN DETAIL
1 1/2" = 1'-0"

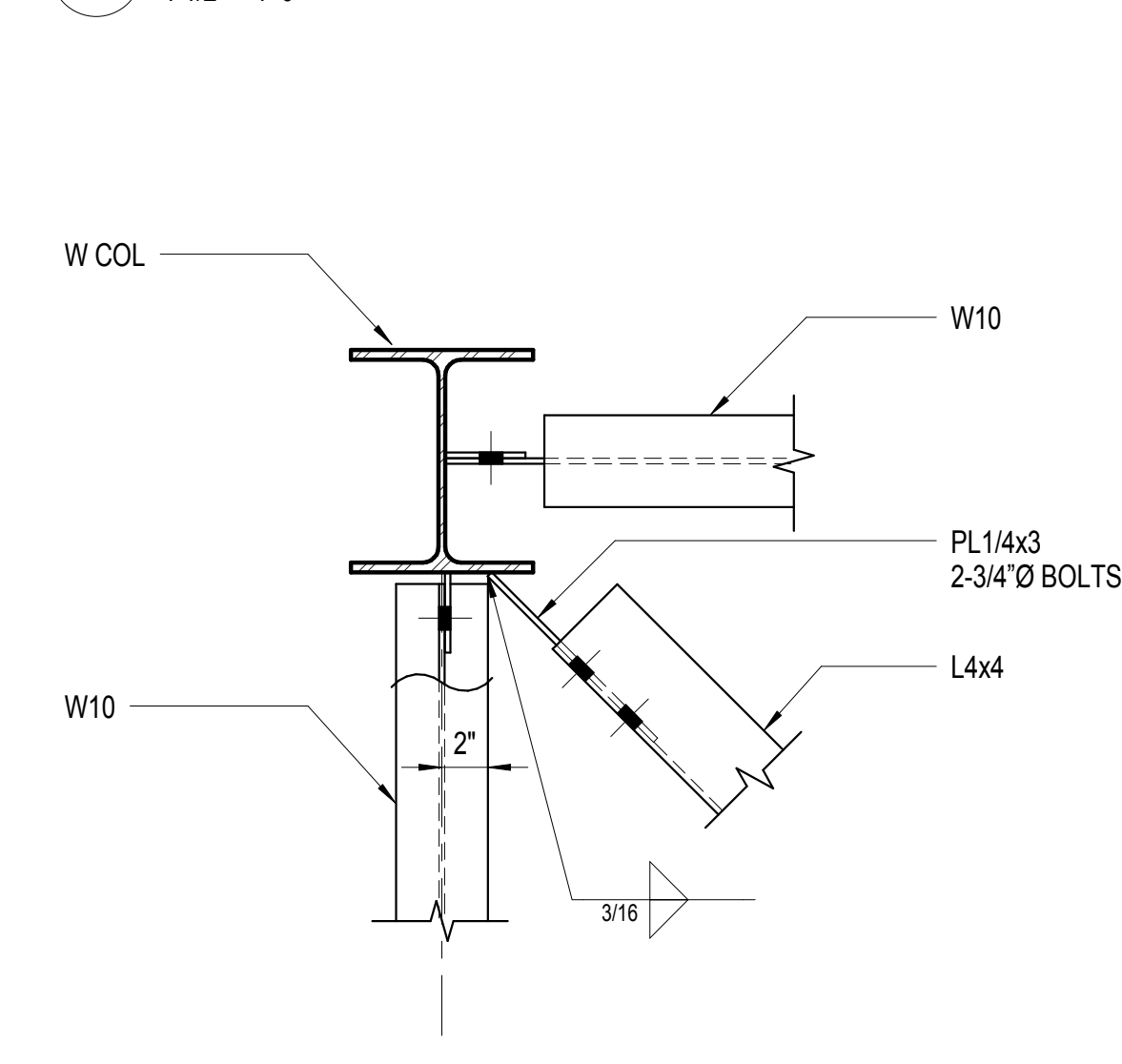

11 BRACE CONN
1 1/2" = 1'-0"

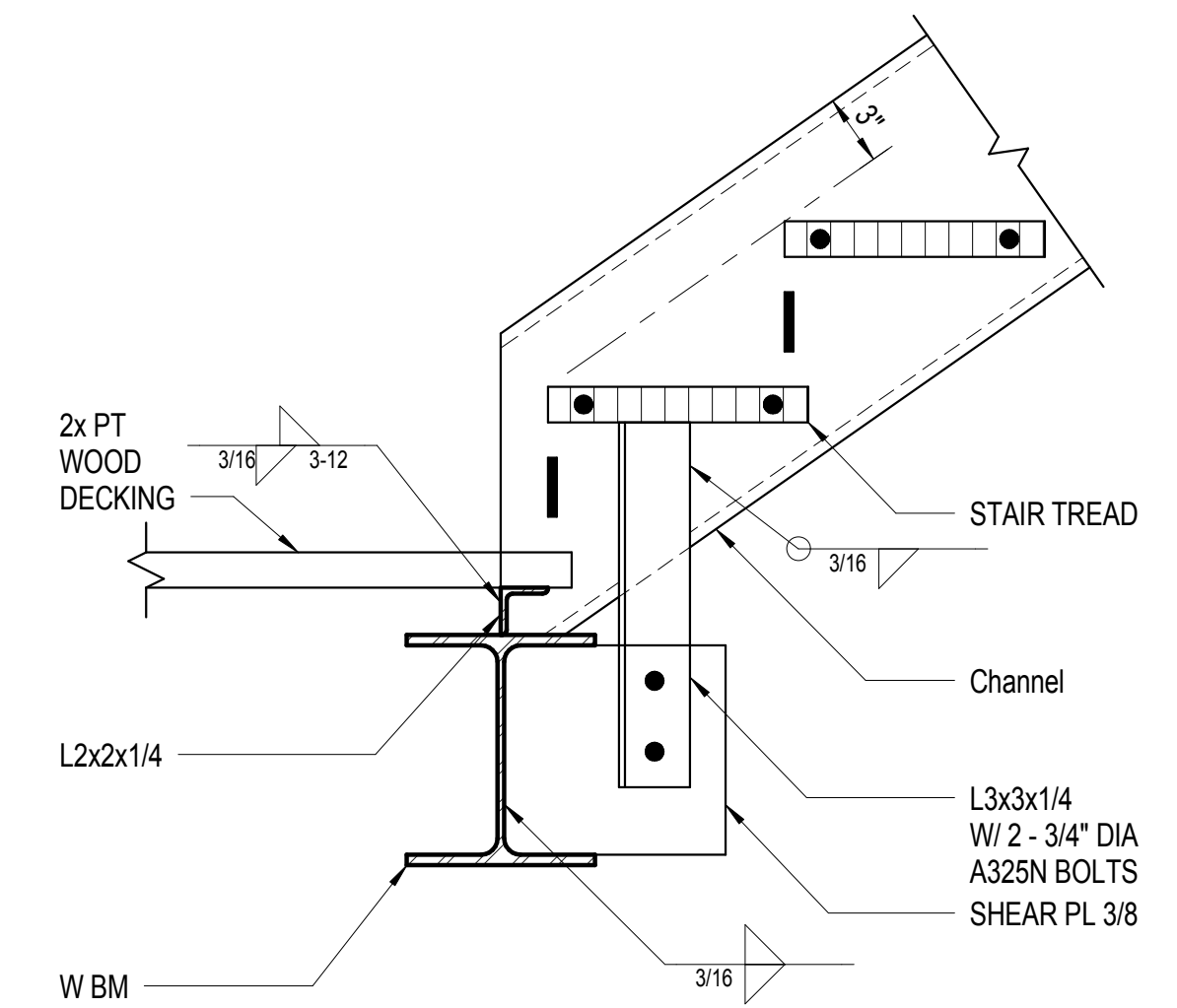

4 CHANNEL TO W BM
1 1/2" = 1'-0"

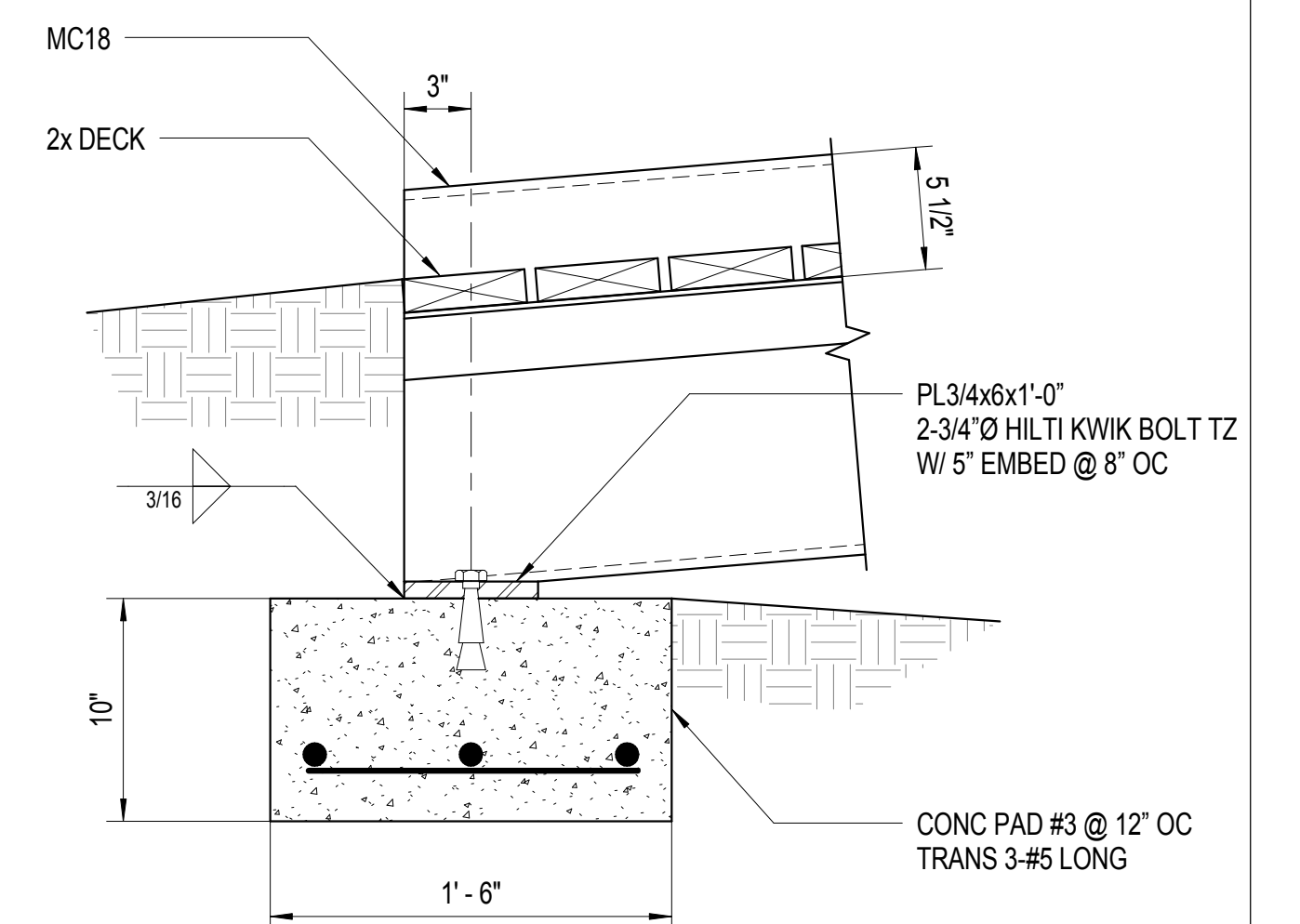

8 RAMP PAD
1 1/2" = 1'-0"

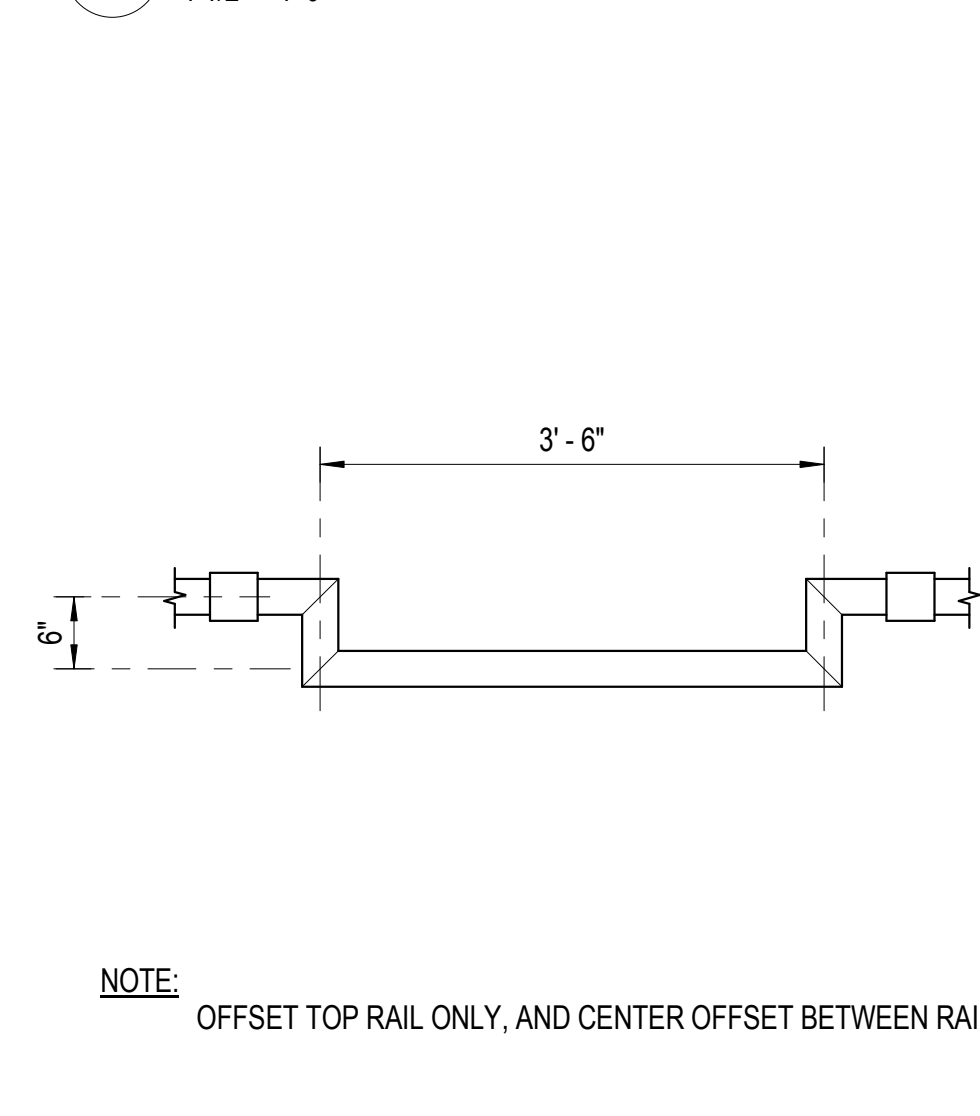

12 RAILING OFFSET
3/4" = 1'-0"

NOTE: OFFSET TOP RAIL ONLY, AND CENTER OFFSET BETWEEN RAIL POST.

Revisions	
#	Date

Drawn CMS	Date 1-31-2013
Checked DLB	Job No. 211090

Sheet Contents
STAIR DETAILS

Drawing No.
S5.2