

# STATE OF ALASKA INVITATION TO BID (ITB)



## FIRE RETARDANT TANK FABRICATION

ITB 2025-1000-0167

ISSUED DECEMBER 13, 2024

**IMPORTANT NOTICE:** If you received this solicitation from the State of Alaska's "Online Public Notice" web site, you must register with the procurement officer listed below if you desire to receive notification of subsequent amendments to the solicitation.

**BIDDER'S NOTICE:** By signature on this form, the bidder certifies that they comply with the following:

- (1) the bidder has a valid Alaska business license or will obtain one prior to award of any contract resulting from this ITB. If the bidder possesses a valid Alaska business license, the license number must be written below or one of the following forms of evidence must be submitted with the bid:
  - a canceled check for the business license fee;
  - a copy of the business license application with a receipt date stamp from the State's business license office;
  - a receipt from the State's business license office for the license fee;
  - a copy of the bidder's valid business license;
  - a sworn notarized affidavit that the bidder has applied and paid for a business license;
- (2) the price(s) submitted was arrived at independently and without collusion, under penalty of perjury, and that the bidder is complying with:
  - the laws of the State of Alaska;
  - the applicable portion of the Federal Civil Rights Act of 1964;
  - the Equal Employment Opportunity Act and the regulations issued thereunder by the state and federal government;
  - the Americans with Disabilities Act of 1990 and the regulations issued thereunder by the state and federal government;
  - the bid will remain open and valid for at least 90 days;
  - all terms and conditions set out in this Invitation to Bid (ITB).

If a bidder does not hold an Alaska Business License (1) at the time designated in the ITB for opening the state will disallow the Alaska Bidder Preference. Bids must also be submitted under the name as appearing on the bidder's current Alaska business license in order to receive the Alaska Bidder Preference. If a bidder fails to comply with (2) of this paragraph, the state may reject the bid, terminate the contract, or consider the contractor in default.

### DEPARTMENT OF NATURAL RESOURCES

DIVISION OF FORESTRY & FIRE PROTECTION

COMPANY SUBMITTING BID

AUTHORIZED SIGNATURE

PROCUREMENT OFFICER:

**MADELYN F. LOWE**

PRINTED NAME

PHONE: (907) 761-6357

EMAIL: [MADELYN.LOWE@ALASKA.GOV](mailto:MADELYN.LOWE@ALASKA.GOV)

DATE

# TABLE OF CONTENTS

<b>SECTION 1. INTRODUCTION &amp; INSTRUCTIONS.....</b>	<b>4</b>
SEC. 1.01 PURPOSE OF THE ITB .....	4
SEC. 1.02 BUDGET .....	4
SEC. 1.03 DEADLINE FOR RECEIPT OF BIDS .....	4
SEC. 1.04 PRIOR EXPERIENCE .....	4
SEC. 1.05 REQUIRED REVIEW .....	4
SEC. 1.06 QUESTIONS PRIOR TO DEADLINE FOR RECEIPT OF BIDS .....	5
SEC. 1.07 SITE INSPECTION.....	5
SEC. 1.08 RETURN INSTRUCTIONS.....	5
SEC. 1.09 ASSISTANCE TO BIDDERS WITH A DISABILITY .....	5
SEC. 1.10 AMENDMENTS TO BIDS .....	6
SEC. 1.11 AMENDMENTS TO THE ITB .....	6
SEC. 1.12 ITB SCHEDULE .....	6
SEC. 1.13 PRE-BID CONFERENCE/TELECONFERENCE .....	6
SEC. 1.14 ALTERNATE BIDS .....	6
SEC. 1.15 SUPPORTING INFORMATION .....	7
SEC. 1.16 FIRM, UNQUALIFIED, AND UNCONDITIONAL OFFER .....	7
<b>SECTION 2. SCOPE OF WORK AND CONTRACT INFORMATION.....</b>	<b>8</b>
SEC. 2.01 SCOPE OF WORK .....	8
SEC. 2.02 CONTRACT TERM .....	9
SEC. 2.03 CONTRACT TYPE .....	9
SEC. 2.04 PAYMENT FOR STATE PURCHASES .....	9
SEC. 2.05 ELECTRONIC PAYMENTS .....	9
SEC. 2.06 PROMPT PAYMENT FOR STATE PURCHASES .....	9
SEC. 2.07 CONTRACT ADMINISTRATION .....	9
SEC. 2.08 CONTRACT PRICE ADJUSTMENTS .....	10
SEC. 2.09 CONTRACT PERFORMANCE LOCATION .....	10
SEC. 2.10 THIRD-PARTY FINANCING AGREEMENTS NOT ALLOWED .....	10
SEC. 2.11 SUBCONTRACTORS.....	10
SEC. 2.12 JOINT VENTURES .....	11
SEC. 2.13 RIGHT TO INSPECT PLACE OF BUSINESS .....	11
SEC. 2.14 F.O.B. POINT .....	11
SEC. 2.15 INSPECTION & MODIFICATION - REIMBURSEMENT FOR UNACCEPTABLE DELIVERABLES .....	11
SEC. 2.16 EQUIPMENT INSPECTION .....	11
SEC. 2.17 NEW EQUIPMENT .....	11
SEC. 2.18 REMANUFACTURED/RECONDITIONED EQUIPMENT .....	11
SEC. 2.19 LEMON CLAUSE .....	12
SEC. 2.20 DISCONTINUED ITEMS.....	12
SEC. 2.21 LIQUIDATED DAMAGES .....	12
SEC. 2.22 SHIPPING DAMAGE .....	12
SEC. 2.23 CONTRACT CHANGES – UNANTICIPATED AMENDMENTS .....	12
SEC. 2.24 CONTINUING OBLIGATION OF CONTRACTOR .....	12
SEC. 2.25 BILLING INSTRUCTIONS .....	13
SEC. 2.26 ESTIMATED QUANTITIES .....	13
SEC. 2.27 WARRANTY .....	13
SEC. 2.28 NONDISCLOSURE AND CONFIDENTIALITY.....	14
SEC. 2.29 INDEMNIFICATION .....	15
SEC. 2.30 INSURANCE .....	15
<b>SECTION 3. BID FORMAT AND CONTENT .....</b>	<b>16</b>
SEC. 3.01 BID FORMS.....	16
SEC. 3.02 BID BOND – PERFORMANCE BOND – SURETY DEPOSIT .....	16
SEC. 3.03 PRICES.....	16

<b>SECTION 4. EVALUATION AND CONTRACTOR SELECTION.....</b>	<b>17</b>
SEC. 4.01 EVALUATION OF BIDS.....	17
SEC. 4.02 APPLICATION OF PREFERENCES.....	17
SEC. 4.03 ALASKA BIDDER PREFERENCE.....	17
SEC. 4.04 ALASKA VETERAN PREFERENCE.....	18
SEC. 4.05 ALASKA MILITARY SKILLS PROGRAM PREFERENCE.....	18
SEC. 4.06 USE OF LOCAL FOREST PRODUCTS.....	19
SEC. 4.07 LOCAL AGRICULTURAL AND FISHERIES PRODUCT PREFERENCE.....	19
SEC. 4.08 ALASKA PRODUCT PREFERENCE.....	19
SEC. 4.09 EMPLOYMENT PROGRAM PREFERENCE.....	19
SEC. 4.10 ALASKANS WITH DISABILITIES PREFERENCE.....	19
SEC. 4.11 PREFERENCE QUALIFICATION LETTER.....	19
SEC. 4.12 EXTENSION OF PRICES.....	19
SEC. 4.13 METHOD OF AWARD.....	19
SEC. 4.14 CONTRACTOR SELECTION PROCESS.....	19
SEC. 4.15 NOTICE OF INTENT TO AWARD.....	20
<b>SECTION 5. GENERAL PROCESS AND LEGAL INFORMATION.....</b>	<b>21</b>
SEC. 5.01 INFORMAL DEBRIEFING.....	21
SEC. 5.02 ALASKA BUSINESS LICENSE AND OTHER REQUIRED LICENSES.....	21
SEC. 5.03 AUTHORITY.....	21
SEC. 5.04 COMPLIANCE.....	21
SEC. 5.05 SUITABLE MATERIALS, ETC.....	22
SEC. 5.06 SPECIFICATIONS.....	22
SEC. 5.07 BRAND SPECIFIC.....	22
SEC. 5.08 ITEM UPGRADES.....	22
SEC. 5.09 WORKMANSHIP AND MATERIALS.....	22
SEC. 5.10 CONTRACTOR SITE INSPECTION.....	22
SEC. 5.11 ORDER DOCUMENTS.....	22
SEC. 5.12 HUMAN TRAFFICKING.....	22
SEC. 5.13 RIGHT OF REJECTION.....	23
SEC. 5.14 STATE NOT RESPONSIBLE FOR PREPARATION COSTS.....	23
SEC. 5.15 DISCLOSURE OF BID CONTENTS.....	23
SEC. 5.16 ASSIGNMENTS.....	24
SEC. 5.17 FORCE MAJEURE (IMPOSSIBILITY TO PERFORM).....	24
SEC. 5.18 DEFAULT.....	24
SEC. 5.19 DISPUTES.....	24
SEC. 5.20 SEVERABILITY.....	24
SEC. 5.21 CONTRACT CANCELLATION.....	24
SEC. 5.22 GOVERNING LAW; FORUM SELECTION.....	24
SEC. 5.23 QUALIFIED BIDDERS.....	25
SEC. 5.24 FEDERALLY IMPOSED TARIFFS.....	25
SEC. 5.25 PROTEST.....	26
<b>SECTION 6. ATTACHMENTS.....</b>	<b>27</b>
SEC. 6.01 ATTACHMENTS.....	27

## SECTION 1. INTRODUCTION & INSTRUCTIONS

### SEC. 1.01 PURPOSE OF THE ITB

The Department of Natural Resources, Division of Forestry & Fire Protection, is soliciting bids for the fabrication of retardant tanks as part of its efforts to modernize wildfire suppression infrastructure. These tanks are critical for storing and deploying fire retardant at air tanker bases across the state, supporting aerial firefighting operations.

The tanks must meet stringent specifications to ensure durability, compatibility with existing systems, and performance in Alaska's extreme conditions. This project is vital to enhancing the state's ability to combat wildfires and protect communities, requiring a qualified contractor with experience in metal fabrication and industrial-grade tank construction.

### SEC. 1.02 BUDGET

Department of **NATURAL RESOURCES**, Division of **FORESTRY & FIRE PROTECTION**, estimates a budget of between **\$180,000.00** and **\$375,000.00** USD for this contract. Bids priced at more than **\$375,000.00** will be considered non-responsive.

Payment for the contract is subject to funds already appropriated and identified.

### SEC. 1.03 DEADLINE FOR RECEIPT OF BIDS

Bids must be received no later than **2:00 PM** Alaska Time on **JANUARY 7, 2025**, at which time they will be publicly opened. Late bids or amendments will be considered non-responsive and will not be opened or accepted for evaluation.

### SEC. 1.04 PRIOR EXPERIENCE

No specific minimums have been set for this ITB.

### SEC. 1.05 REQUIRED REVIEW

Bidders shall carefully review this ITB for defects and questionable or objectionable material. Comments concerning defects and questionable or objectionable material in the ITB should be made in writing and received by the procurement officer at least ten days before the deadline for receipt of bids. This will allow time for an amendment to be issued if one is required. It will also help prevent the opening of a defective bid, upon which award cannot be made, and the resultant exposure of bidders' prices.

**SEC. 1.06 QUESTIONS PRIOR TO DEADLINE FOR RECEIPT OF BIDS**

All questions must be in writing and directed to the procurement officer. The interested party must confirm telephone conversations in writing. Two types of questions generally arise. One may be answered by directing the questioner to a specific section of the ITB. These questions may be answered over the telephone. Other questions may be more complex and may require a written amendment to the ITB. The procurement officer will make that decision.

Deadline to receive questions is **DECEMBER 27, 2024**, by **2:00 PM** Alaska Time.

Procurement Officer: **MADelyn F. LOWE**  
Phone: **(907) 761-6357**  
Email: **madelyn.lowe@alaska.gov**

**SEC. 1.07 SITE INSPECTION**

Not applicable to this ITB.

**SEC. 1.08 RETURN INSTRUCTIONS**

If submitting a bid via email, the Bid Schedule must be saved as a PDF document and emailed to **madelyn.lowe@alaska.gov**. The PDF document must be clearly labeled such as “Vendor A – Bid Schedule.pdf” (Vendor A is the name of the bidder). The email must contain the ITB number in the subject line.

The **maximum** size of a single email (including all text and attachments) that can be received by the State is **20mb (megabytes)**. If the email containing the bid exceeds this size, the bid must be sent in multiple emails that are each less than 20 megabytes and each email must comply with the requirements described above.

Please note that email transmission is not instantaneous. Similar to sending a hard copy bid, if you are emailing your bid, the State recommends sending it enough ahead of time to ensure the email is delivered by the deadline for receipt of bid.

If submitting bids using U.S. mail, or delivery service, bidders must submit one hard copy of their bid, in writing, to the Procurement Officer in a sealed package. The sealed bid package must be addressed as follows:

Department of Natural Resources  
Division of Forestry & Fire Protection  
Attention: **MADelyn F. LOWE**  
Invitation to Bid (ITB) Number: 2025-1000-0167  
ITB Title: FIRE RETARDANT TANK FABRICATION  
101 Airport Road  
Palmer, Alaska 99645

It is the bidder’s responsibility to contact the issuing agency at **1 (907) 761-6357** or **madelyn.lowe@alaska.gov** to confirm that the bid has been received. The State is not responsible for unreadable, corrupt, or missing attachments.

**SEC. 1.09 ENROLLMENT IN IRIS**

Bidders will be required to be enrolled in the State of Alaska’s Integrated Resource Information System (IRIS) database prior to the award of a contract resulting from this ITB. Enrollment can be done online at the following link: <https://iris-vss.alaska.gov>. Bidders who are not enrolled prior to the award of a contract will be notified by the Procurement Officer. Failure of a bidder to enroll in the IRIS database will delay award of the contract and may delay issuance of contract work.

**SEC. 1.10 ASSISTANCE TO BIDDERS WITH A DISABILITY**

The State of Alaska complies with Title II of the Americans with Disabilities Act of 1990. Individuals with disabilities who may need auxiliary aids, services, and/or special modifications to submit a bid should contact the Procurement Officer no later than ten days prior to the closing of the bid to make any necessary arrangements.

**SEC. 1.11 AMENDMENTS TO BIDS**

Amendments to or withdrawals of bids will only be allowed if acceptable requests are received prior to the deadline that is set for receipt of bids, in accordance with 2 AAC 12.140. No amendments or withdrawals will be accepted after the deadline unless the delay is due to an error of the contracting agency, in accordance with 2 AAC 12.160.

**SEC. 1.12 AMENDMENTS TO THE ITB**

If an amendment is issued before the deadline for receipt of bids, the amendment will be posted on the State of Alaska Online Public Notice (OPN) website. The link to the posting of the amendment will be provided to all who were notified of the ITB and to those who have registered with the procurement officer after receiving the ITB from the OPN.

**SEC. 1.13 ITB SCHEDULE**

The ITB schedule below represents the State of Alaska’s best estimate of the schedule that will be followed. If a component of this schedule, such as the deadline for receipt of bids, is delayed, the rest of the schedule may be shifted accordingly. All times are Alaska Standard Time (AST).

ACTIVITY	TIME	DATE
Issue Date / ITB Released	N/A	December 13, 2024
Deadline for Receipt of Questions	2:00 PM	December 27, 2024
Deadline for Receipt of Bids / Bid Due Date	2:00 PM	January 7, 2025
ANTICIPATED Bid Evaluations Complete	Week of	January 7, 2025
ANTICIPATED Notice of Intent to Award	Week of	January 7, 2025
ANTICIPATED Contract Issued	Week of	January 13, 2025

This ITB does not, by itself, obligate the state. The state's obligation will commence when the contract is approved by the Commissioner of the Department of **NATURAL RESOURCES**, or the Commissioner's designee. Upon written notice to the contractor, the state may set a different starting date for the contract. The state will not be responsible for any work done by the contractor, even work done in good faith, if it occurs prior to the contract start date set by the state.

**SEC. 1.14 PRE-BID CONFERENCE/TELECONFERENCE**

Not applicable to this ITB.

**SEC. 1.15 ALTERNATE BIDS**

Bidders may only submit one bid for evaluation. In accordance with 2 AAC 12.830 alternate bids (bids that offer something different than what is asked for) will be rejected.

**SEC. 1.16 SUPPORTING INFORMATION**

Provided a bid meets the requirements for a definite, firm, unqualified, and unconditional offer, the state reserves the right to request supplemental information from the bidder, after the bids have been opened, to ensure that the products or services offered completely meet the ITB requirements. The requirement for such supplemental information will be at the reasonable discretion of the state and may include the requirement that a bidder will provide a sample product(s) so that the state can make a first-hand examination and determination.

A bidder's failure to provide this supplemental information or the product sample(s), within the time set by the state, may cause the state to consider the offer non-responsive and reject the bid.

**SEC. 1.17 FIRM, UNQUALIFIED, AND UNCONDITIONAL OFFER**

To be responsive a bid must constitute a definite, firm, unqualified and unconditional offer to meet all the material terms of the ITB. Material terms are those that could affect the price, quantity, quality, or delivery. Also included as material terms are those which are clearly identified in the ITB, and which must be complied with at risk of bid rejection for non-responsiveness.

## SECTION 2. SCOPE OF WORK AND CONTRACT INFORMATION

### SEC. 2.01 SCOPE OF WORK

Division of Forestry & Fire Protection requires the fabrication, delivery, and installation of four fire-retardant storage tank systems as outlined below. The successful contractor will furnish and install all components in compliance with the specifications, ensuring full functionality and reliability.

Fabrication of the tank will take place at the contractor's facility. The Project Manager or designated party will inspect the tank at the contractor's facility prior to delivery and installation. The intended destination of the completed tanks is one to Tanacross Airfield and the remaining three to Kenai Municipal Airport.

#### Fire Retardant Storage Tank

- Capacity: Minimum 10,000 gallons.
- Construction: Shop-fabricated, welded steel tank with a minimum gauge of 2 steel.
- Mounting: Tank shall be skid-mounted, supported by a minimum of five saddles for stability.
- Exterior Coating: Prime the exterior with an iron oxide primer and finish with a white Chemline polyurethane paint to prevent corrosion. (Alternative coatings subject to approval by PM. Any alternatives must be equal or better quality.)
- Interior Coating: Apply Devoe Devmat 111 coating to a suitably prepared interior surface for durability and chemical resistance. (Alternative coatings subject to approval by PM. Any alternatives must be equal or better quality.)
- Manholes and Tappings: Provide manholes and tappings as specified in Attachment 6 for safe access and connection points. Attention shall be given to drain connections and interior piping requirements.
- Labeling: Stencil "FIRE RETARDANT" on both ends of the tank in letters no smaller than 6 inches for clear identification.

#### Mechanical Specifications

- Materials: All materials shall be new and unused. Installation must follow manufacturer guidelines and adhere to best practices.
- Project Manager Approval: Contractor must obtain the Project Managers approval for all products prior to ordering or installation.

#### Compressed Air Piping

- Specifications: Use ASTM A53, Schedule 40 steel pipe with threaded fittings.
- Coating: Apply specified coating after drilling bubbler holes to maintain corrosion resistance and durability.

#### Retardant Recirculation Piping

- Specifications: Use ASTM A53, Schedule 40 steel pipe with threaded fittings.
- Coating: Apply specified coating after drilling recirculation holes to prevent interior corrosion and ensure smooth operation.



**Valves**

- Butterfly Valves: Iron body with a bronze disc, resilient seat for temperature range of -40°F to 120°F, lug ends, and 10-position lever handle.
- Ball Valves: Bronze two-piece body, full port with forged brass, chrome-plated ball, Teflon seats, and threaded ends with union. Seat material must be compatible with fire retardant fluid.

**Operation and Maintenance Manual**

- Documentation: Provide a comprehensive operation and maintenance manual, including manufacturer's specifications, installation, and maintenance instructions. Include warranty details and contact information for spare parts and service providers.

**SEC. 2.02 CONTRACT TERM**

The length of the contract will be from the date of award for approximately **1 year** until completion.

**SEC. 2.03 CONTRACT TYPE**

This contract is a firm fixed price contract.

**SEC. 2.04 PAYMENT FOR STATE PURCHASES**

No payment will be made until the contract is approved by the Commissioner of the Department of **NATURAL RESOURCES** or the Commissioner's designee. Under no conditions will the state be liable for the payment of any interest charges associated with the cost of the contract. The state is not responsible for and will not pay local, state, or federal taxes. All costs associated with the contract must be stated in U.S. currency.

Payment for agreements under \$500,000 for the undisputed purchase of goods or services provided to a state agency, will be made within 30 days of the receipt of a proper billing or the delivery of the goods or services to the location(s) specified in the agreement, whichever is later. A late payment is subject to 1.5% interest per month on the unpaid balance. Interest will not be paid if there is a dispute or if there is an agreement that establishes a lower interest rate or precludes the charging of interest.

**SEC. 2.05 ELECTRONIC PAYMENTS**

The State of Alaska prefers vendors receive payment via Electronic Funds Transfer (EFT). Bidders may review information concerning the EFT process and access the [Electronic Payment Agreement Form for Vendors](https://doa.alaska.gov/dof/vendor.html) at the following link: <https://doa.alaska.gov/dof/vendor.html>. Method of payment is not a factor in the State's determination for award.

Any single contract payments of \$1 million or higher must be accepted by the contractor via Electronic Funds Transfer (EFT).

**SEC. 2.06 PROMPT PAYMENT FOR STATE PURCHASES**

Not applicable to this ITB.

**SEC. 2.07 CONTRACT ADMINISTRATION**

The administration of this contract is the responsibility of the procurement officer or person appointed by the Department of **Natural Resources**, Division of **Forestry & Fire Protection**.

**SEC. 2.08 CONTRACT PRICE ADJUSTMENTS**

Not applicable to this ITB.

**SEC. 2.09 CONTRACT PERFORMANCE LOCATION**

The State **WILL NOT** provide workspace for the contractor. The contractor must provide its own workspace.

By signature on their bid, the bidder certifies that all services provided under this contract by the contractor and all subcontractors shall be performed in the United States.

If the bidder cannot certify that all work will be performed in the United States, the bidder must contact the procurement officer in writing to request a waiver at least 10 days prior to the deadline for receipt of bids.

The request must include a detailed description of the portion of work that will be performed outside the United States, where, by whom, and the reason the waiver is necessary.

Failure to comply with these requirements may cause the state to reject the bid as non-responsive or cancel the contract.

**SEC. 2.10 THIRD-PARTY FINANCING AGREEMENTS NOT ALLOWED**

Because of the additional administrative and accounting time required of the state when third party financing agreements are permitted, they will not be allowed under this contract.

**SEC. 2.11 SUBCONTRACTORS**

Subcontractors may be used to perform work under this contract. If a bidder intends to use subcontractors, the bidder must identify in the bids the names of the subcontractors and the portions of the work the subcontractors will perform.

Subcontractor experience **SHALL** be considered in determining whether the bidder meets the requirements set forth in **SEC. 2.01 PRIOR EXPERIENCE**.

If a bid with subcontractors is selected, the bidder must provide the following information concerning each prospective subcontractor within five working days from the date of the state's request:

- complete name of the subcontractor;
- complete address of the subcontractor;
- type of work the subcontractor will be performing;
- percentage of work the subcontractor will be providing;
- evidence that the subcontractor holds a valid Alaska business license; and
- a written statement signed by each proposed subcontractor that clearly verifies that the subcontractor is committed to render the services required by the contract.

A bidder's failure to provide this information, within the time set, may cause the state to consider their bid non-responsive and reject it.

Note that if the subcontractor will not be performing work within Alaska, they will not be required to hold an Alaska business license.

**SEC. 2.12 JOINT VENTURES**

Joint ventures will not be allowed.

**SEC. 2.13 RIGHT TO INSPECT PLACE OF BUSINESS**

At reasonable times, the state may inspect those areas of the contractor's place of business that are related to the performance of a contract. If the state makes such an inspection, the contractor must provide reasonable assistance.

**SEC. 2.14 F.O.B. POINT**

The F.O.B. point for all items purchased under this contract is the final destination anywhere within the State of Alaska. Ownership of and title to the ordered items remains with the contractor until the items have been delivered to their final destination and are accepted by the state.

The cost of shipping and delivery to Tanacross Airfield and Kenai Municipal Airport is to be included in the bid price. There will be no additional charge for shipping and delivery.

**SEC. 2.15 INSPECTION & MODIFICATION - REIMBURSEMENT FOR UNACCEPTABLE DELIVERABLES**

The contractor is responsible for providing all products or the completion of all work set out in the contract. All products or work is subject to inspection, evaluation, and approval by the state. The state may employ all reasonable means to ensure that the work is progressing and being performed in compliance with the contract. The state may instruct the contractor to make corrections or modifications if needed in order to accomplish the contract's intent. The contractor will not unreasonably withhold such changes.

Substantial failure of the contractor to perform the contract may cause the state to terminate the contract. In this event, the state may require the contractor to reimburse monies paid (based on the identified portion of unacceptable products or work received) and may seek associated damages.

**SEC. 2.16 EQUIPMENT INSPECTION**

Equipment offered (including for lease) may be subject to inspection and approval by the state prior to the award of the ITB. The equipment and attachments must be in good repair and capable of performing the work for which they were designed.

**SEC. 2.17 NEW EQUIPMENT**

Equipment offered in response to this ITB must be new equipment. New equipment means equipment that is currently in production by the manufacturer and is still the latest model, edition or version generally offered. The equipment must be warranted as new by the manufacturer and may not have been used for any purpose, other than display (not demonstration), prior to its sale to the state. The state will not accept remanufactured, used, or reconditioned equipment. It is the contractor's responsibility to ensure that each piece of equipment delivered to the state complies with this requirement. A contractor's failure to comply with this requirement will cause the state to seek remedies under breach of contract.

**SEC. 2.18 REMANUFACTURED/RECONDITIONED EQUIPMENT**

Not applicable to this ITB.

**SEC. 2.19 LEMON CLAUSE**

This clause applies to all equipment purchased through this contract. The application period is **1 YEAR** from the date of installation. This clause takes precedence over any other warranty or service maintenance clauses associated with this contract.

Any equipment that fails (except due to operator error) to operate according to the manufacturer's published performance specifications and/or is subject to recurring related problems must be replaced with the same make and model of new equipment at no cost to the state.

**SEC. 2.20 DISCONTINUED ITEMS**

In the event an item is discontinued by the manufacturer during the life of the contract, another item may be substituted, provided that the procurement officer makes a written determination that it is equal to or better than the discontinued item and provided that it is sold at the same price or less than the discontinued item.

**SEC. 2.21 LIQUIDATED DAMAGES**

Not applicable to this ITB.

**SEC. 2.22 SHIPPING DAMAGE**

The state will not accept or pay for damaged goods. The contractor must file all claims against the carrier(s) for damages incurred to items in transit from the point of origin to the ultimate destination. The state will provide the contractor with written notice when damaged goods are received. The state will deduct the cost of the damaged goods from the invoice prior to payment. The contractor must file all claims against the carrier(s) for reimbursement of the loss.

**SEC. 2.23 CONTRACT CHANGES – UNANTICIPATED AMENDMENTS**

During the course of this contract, the contractor may be required to perform additional work. That work will be within the general scope of the initial contract. When additional work is required, the state will provide the contractor a written description of the additional work and request the contractor to submit a firm time schedule for accomplishing the additional work and a firm price for the additional work. Cost and pricing data must be provided to justify the cost of such amendments per AS 36.30.400.

The contractor will not commence additional work until the procurement officer has secured required state approvals necessary and issued a written contract amendment.

**SEC. 2.24 CONTINUING OBLIGATION OF CONTRACTOR**

Notwithstanding the expiration date of a contract resulting from this ITB, the contractor is obligated to fulfill its responsibilities until warranty, guarantee, maintenance, and parts availability requirements have completely expired.

**SEC. 2.25 BILLING INSTRUCTIONS**

All invoices produced by the contractor must contain the following information at a minimum:

1. **CONTRACT NUMBER AND TITLE;**
2. **IDENTIFICATION OF BILLING PERIOD;**
3. **ITEMIZED LIST OF DELIVERABLES AND CHARGES FOR INVOICED PERIOD;**
4. **TOTAL AMOUNT BILLED;**
5. **DATE INVOICE SUBMITTED FOR PAYMENT;**
6. **ENTITY NAME, CONTACT INFORMATION, AND ALASKA VENDOR NUMBER.**

Invoices must be billed to the ordering agency's address shown on the individual Purchase Order, Contract Award or Delivery Order. The state will make payment after it receives the goods or services and the invoice. Questions concerning payment must be addressed to the ordering agency.

**SEC. 2.26 ESTIMATED QUANTITIES**

The quantities referenced in this ITB are estimated requirements and may vary more or less from the quantities actually purchased. The State does not guarantee any minimum or maximum purchase. Orders will be issued throughout the contract period on an as-needed basis.

**SEC. 2.27 WARRANTY**

The contractor warrants every unit purchased against faulty materials and workmanship for a minimum period of at least **LENGTH**. If, during this period, faults develop with the unit or components of the unit, they will be repaired or replaced without any cost, including any transportation or freight cost, to the state. Bids, which include supplemental warranties, will be accepted, but supplemental warranties that conflict with or diminish the state's rights under this warranty clause will be considered null and void. The state is not responsible for identifying conflicting warranty conditions before issuing a contract award. After award of the contract:

1. if a conflict arises between the supplemental warranty and the warranty in this ITB, the warranty in the ITB will prevail; and
2. if the state's rights are diminished as a result of application of the supplemental warranty, the supplemental warranty will be considered null and void and the ITB warranty will prevail.

By signature on the face page of this ITB the bidder acknowledges this requirement and indicates unconditional acceptance of this warranty clause.

**SEC. 2.28 NONDISCLOSURE AND CONFIDENTIALITY**

Contractor agrees that all confidential information shall be used only for purposes of providing the deliverables and performing the services specified herein and shall not disseminate or allow dissemination of confidential information except as provided for in this section. The contractor shall hold as confidential and will use reasonable care (including both facility physical security and electronic security) to prevent unauthorized access by, storage, disclosure, publication, dissemination to and/or use by third parties of, the confidential information. “Reasonable care” means compliance by the contractor with all applicable federal and state law, including the Social Security Act and HIPAA. The contractor must promptly notify the state in writing if it becomes aware of any storage, disclosure, loss, unauthorized access to or use of the confidential information.

Confidential information, as used herein, means any data, files, software, information or materials (whether prepared by the state or its agents or advisors) in oral, electronic, tangible or intangible form and however stored, compiled or memorialized that is classified confidential as defined by State of Alaska classification and categorization guidelines provided by the state to the contractor or a contractor agent or otherwise made available to the contractor or a contractor agent in connection with this contract, or acquired, obtained or learned by the contractor or a contractor agent in the performance of this contract. Examples of confidential information include, but are not limited to technology infrastructure, architecture, financial data, trade secrets, equipment specifications, user lists, passwords, research data, and technology data (infrastructure, architecture, operating systems, security tools, IP addresses, etc.).

If confidential information is requested to be disclosed by the contractor pursuant to a request received by a third party and such disclosure of the confidential information is required under applicable state or federal law, regulation, governmental or regulatory authority, the contractor may disclose the confidential information after providing the state with written notice of the requested disclosure ( to the extent such notice to the state is permitted by applicable law) and giving the state opportunity to review the request. If the contractor receives no objection from the state, it may release the confidential information within 30 days. Notice of the requested disclosure of confidential information by the contractor must be provided to the state within a reasonable time after the contractor’s receipt of notice of the requested disclosure and, upon request of the state, shall seek to obtain legal protection from the release of the confidential information.

The following information shall not be considered confidential information: information previously known to be public information when received from the other party; information freely available to the general public; information which now is or hereafter becomes publicly known by other than a breach of confidentiality hereof; or information which is disclosed by a party pursuant to subpoena or other legal process and which as a result becomes lawfully obtainable by the general public.

**SEC. 2.29 INDEMNIFICATION**

The contractor shall indemnify, hold harmless, and defend the contracting agency from and against any claim of, or liability for error, omission or negligent act of the contractor under this agreement. The contractor shall not be required to indemnify the contracting agency for a claim of, or liability for, the independent negligence of the contracting agency. If there is a claim of, or liability for, the joint negligent error or omission of the contractor and the independent negligence of the contracting agency, the indemnification and hold harmless obligation shall be apportioned on a comparative fault basis.

“Contractor” and “contracting agency”, as used within this and the following article, include the employees, agents and other contractors who are directly responsible, respectively, to each. The term “independent negligence” is negligence other than in the contracting agency’s selection, administration, monitoring, or controlling of the contractor and in approving or accepting the contractor’s work.

**SEC. 2.30 INSURANCE**

Without limiting the contractor's indemnification, it is agreed that the contractor shall purchase at its own expense and maintain in force at all times during the performance of services under this agreement the following policies of insurance. Where specific limits are shown, it is understood that they shall be the minimum acceptable limits. If the contractor's policy contains higher limits, the state shall be entitled to coverage to the extent of such higher limits.

Certificates of Insurance must be furnished to the procurement officer prior to contract approval and must provide for a notice of cancellation, non-renewal, or material change of conditions in accordance with policy provisions. Failure to furnish satisfactory evidence of insurance or lapse of the policy is a material breach of this contract and shall be grounds for termination of the contractor's services. All insurance policies shall comply with and be issued by insurers licensed to transact the business of insurance under AS 21.

**Proof of insurance is required for the following:**

- Workers' Compensation Insurance: The contractor shall provide and maintain, for all employees engaged in work under this contract, coverage as required by AS 23.30.045, and where applicable, any other statutory obligations including but not limited to Federal U.S.L. & H. and Jones Act requirements. The policy must waive subrogation against the state.
- Commercial General Liability Insurance: covering all business premises and operations used by the contractor in the performance of services under this agreement with minimum coverage limits of \$300,000 combined single limit per occurrence.
- Commercial Automobile Liability Insurance: covering all vehicles used by the contractor in the performance of services under this agreement with minimum coverage limits of \$300,000 combined single limit per occurrence.

## SECTION 3. BID FORMAT AND CONTENT

### SEC. 3.01 BID FORMS

Bidders shall use the front page of this ITB, the Bid Submission Cover Sheet, and any other forms identified in this ITB for submitting bids. All bids must be signed by an individual authorized to bind the bidder to the provisions of the ITB.

#### BIDDER'S CERTIFICATION

By signature on the bid, the bidder certifies that they comply with the following:

- B. the laws of the State of Alaska;
- C. the applicable portion of the Federal Civil Rights Act of 1964;
- D. the Equal Employment Opportunity Act and the regulations issued thereunder by the state and federal government;
- E. the Americans with Disabilities Act of 1990 and the regulations issued thereunder by the state and federal government and certifies that programs, services, and activities provided to the general public on behalf of the State under a contract resulting from this solicitation comply with the Americans with Disabilities Act of 1990, 28 CFR, Part 35, Subpart B 35.130;
- F. all terms and conditions set out in this ITB;
- G. the price(s) submitted was arrived at independently arrived and without collusion, under penalty of perjury; and
- H. that the bid will remain open and valid for at least 90 days.

If any bidder fails to comply with [a] through [g] of this paragraph, the state reserves the right to disregard the bid, terminate the contract, or consider the contractor in default.

#### CONFLICT OF INTEREST

Each bid shall include a statement indicating whether the company or any individuals working on the contract has a possible conflict of interest (e.g., currently employed by the State of Alaska or formerly employed by the State of Alaska within the past two years) and, if so, the nature of that conflict. The procurement officer reserves the right to **consider a bid non-responsive and reject it** or cancel the award if any interest disclosed from any source could either give the appearance of a conflict or cause speculation as to the objectivity of the contract to be performed by the bidder.

### SEC. 3.02 BID BOND – PERFORMANCE BOND – SURETY DEPOSIT

Not applicable to this ITB.

### SEC. 3.03 PRICES

The bidder shall state prices in the units of issue on this ITB. Prices quoted in bids must be exclusive of federal, state, and local taxes. If the bidder believes that certain taxes are payable by the state, the bidder may list such taxes separately, directly below the bid price for the affected item.



## SECTION 4. EVALUATION AND CONTRACTOR SELECTION

### SEC. 4.01 EVALUATION OF BIDS

After bid opening, the procurement officer will evaluate the bids for responsiveness. Bids deemed non-responsive will be eliminated from further consideration. An evaluation may not be based on discrimination due the race, religion, color, national origin, sex, age, marital status, pregnancy, parenthood, disability, or political affiliation of the bidder.

### SEC. 4.02 APPLICATION OF PREFERENCES

Certain preferences apply to all state contracts, regardless of their dollar value. The Alaska Bidder and Alaska Veteran preferences are the most common preferences involved in the ITB process. Additional preferences that may apply to this procurement are listed below. Guides that contain excerpts from the relevant statutes and codes, explain when the preferences apply and provide examples of how to calculate the preferences are available at the following website:

<https://oppm.doa.alaska.gov/policy-oversight/policy-resources/user-guide-matrixes/>

- Alaska Military Skills Program Preference – AS 36.30.321(I)
- Alaska Products Preference - AS 36.30.332
- Recycled Products Preference - AS 36.30.337
- Local Agriculture and Fisheries Products Preference - AS 36.15.050
- Employment Program Preference - AS 36.30.321(b)
- Alaskans with Disabilities Preference - AS 36.30.321(d)

The Division of Vocational Rehabilitation in the Department of Labor and Workforce Development keeps a list of qualified employment programs and individuals who qualify as persons with a disability. As evidence of a business' or an individual's right to the Employment Program or Alaskans with Disabilities preferences, the Division of Vocational Rehabilitation will issue a certification letter. To take advantage of these preferences, a business or individual must be on the appropriate Division of Vocational Rehabilitation list prior to the time designated for receipt of proposals. Bidders must attach a copy of their certification letter to the proposal. **A bidder's failure to provide this certification letter with their proposal will cause the state to disallow the preference.**

### SEC. 4.03 ALASKA BIDDER PREFERENCE

An Alaska Bidder Preference of 5% will be applied to the total bid price. The preference will be given to a bidder who:

- 1) holds a current Alaska business license prior to the deadline for receipt of bids;
- 2) submits a bid for goods or services under the name appearing on the bidder's current Alaska business license;
- 3) has maintained a place of business within the state staffed by the bidder, or an employee of the bidder, for a period of six months immediately preceding the date of the bid;
- 4) is incorporated or qualified to do business under the laws of the state, is a sole proprietorship and the proprietor is a resident of the state, is a limited liability company (LLC) organized under AS 10.50 and all members are residents of the state, or is a partnership under AS 32.06 or AS 32.11 and all partners are residents of the state; and
- 5) if a joint venture, is composed entirely of ventures that qualify under (1)-(4) of this subsection.

**Alaska Bidder Preference Certification Form**

To receive the Alaska Bidder Preference, the bid must include the Alaska Bidder Preference Certification Form attached to this ITB. A bidder does not need to complete the Alaska Veteran Preference questions on the form if not claiming the Alaska Veteran Preference. A bidder's failure to provide this completed form with their bid will cause the state to disallow the preference.

**SEC. 4.04 ALASKA VETERAN PREFERENCE**

An Alaska Veteran Preference of 5%, not to exceed \$5,000, will be applied to the total bid price. The preference will be given to a bidder who qualifies under AS 36.30.990(2) as an Alaska Bidder and is a:

- a) sole proprietorship owned by an Alaska veteran;
- b) partnership under AS 32.06 or AS 32.11 if a majority of the partners are Alaska veterans;
- c) limited liability company organized under AS 10.50 if a majority of the members are Alaska veterans; or
- d) corporation that is wholly owned by individuals, and a majority of the individuals are Alaska veterans.

In accordance with AS 36.30.321(i), the bidder must also add value by actually performing, controlling, managing, and supervising the services provided, or for supplies, the bidder must have sold supplies of the general nature solicited to other state agencies, other government, or the general public.

**Alaska Veteran Preference Certification**

To receive the Alaska Veteran Preference, the bid must include the Alaska Bidder Preference Certification Form attached to this ITB. A bidder's failure to provide this completed form with their bid will cause the state to disallow the preference.

**SEC. 4.05 ALASKA MILITARY SKILLS PROGRAM PREFERENCE**

An Alaska Military Skills Program Preference of 2%, not to exceed \$5,000, will be applied to the price in the proposal. The preference will be given to an offeror who qualifies under AS 36.30.990(2) as an Alaska bidder and:

- a) Employs at least one person who is currently enrolled in, or within the previous two years graduated from, a United States Department of Defense SkillBridge or United States Army career skills program for service members or spouses of service members that offers civilian work experience through specific industry training, pre-apprenticeships, registered apprenticeships, or internships during the last 180 days before a service member separates or retires from the service; or
- b) has an active partnership with an entity that employs an apprentice through a program described above.

In accordance with AS 36.30.321(i), the bidder must also add value by actually performing, controlling, managing, and supervising the services provided, or for supplies, the bidder must have sold supplies of the general nature solicited to other state agencies, other government, or the general public.

**Alaska Military Skills Program Preference Certification**

In order to receive the Alaska Military Skills Program Preference, the bid must include the Alaska Bidder Preference Certification Form attached to this ITB. A bidder's failure to provide this completed form with their bid will cause the state to disallow the preference.

In addition, proof of graduation of the qualifying employee from an eligible program as described in AS 36.30.321(l) must be provided to the Procurement Officer at time of bid submission. Bidders must provide clarification or additional information requested by the Procurement Officer related to the preference not later than 5:00 PM Alaska Time one (1) business day following the date of the request. Failure to provide sufficient documentation will result in the bidder not receiving the Military Skills Program Preference.

**SEC. 4.06 USE OF LOCAL FOREST PRODUCTS**

Not applicable to this ITB.

**SEC. 4.07 LOCAL AGRICULTURAL AND FISHERIES PRODUCT PREFERENCE**

Not applicable to this ITB.

**SEC. 4.08 ALASKA PRODUCT PREFERENCE**

Not applicable to this ITB.

**SEC. 4.09 EMPLOYMENT PROGRAM PREFERENCE**

If a bidder qualifies for the Alaska Bidder Preference and is offering goods or services through an employment program as defined under AS 36.30.990(12), an Employment Program Preference of 15% will be applied to the total bid price.

In accordance with AS 36.30.321(i), the bidder must also add value by actually performing, controlling, managing, and supervising the services provided, or for supplies, the bidder must have sold supplies of the general nature solicited to other state agencies, other government, or the general public.

**SEC. 4.10 ALASKANS WITH DISABILITIES PREFERENCE**

If a bidder qualifies for the Alaska Bidder Preference and is a qualifying entity as defined in AS 36.30.321(d), an Alaskans with Disabilities Preference of 10% will be applied to the total bid price.

In accordance with AS 36.30.321(i), the bidder must also add value by actually performing, controlling, managing, and supervising the services provided, or for supplies, the bidder must have sold supplies of the general nature solicited to other state agencies, other government, or the general public.

**SEC. 4.11 PREFERENCE QUALIFICATION LETTER**

Regarding the Employment Program Preference and the Alaskans with Disabilities Preference, the Division of Vocational Rehabilitation in the Department of Labor and Workforce Development maintains lists companies who qualify for those preferences. As evidence of a company's right to the preferences, the Division of Vocational Rehabilitation will issue a certification letter. To take advantage of the preferences, a bidder must be on the appropriate Division of Vocational Rehabilitation list at the time the bid is opened and must attach a copy of their certification letter to their bid. The bidder's failure to provide this certification letter with their bid will cause the state to disallow the preference.

**SEC. 4.12 EXTENSION OF PRICES**

In case of error in the extension of prices in the bid, the unit prices will govern; in a lot bid, the lot prices will govern.

**SEC. 4.13 METHOD OF AWARD**

Award will be made to the lowest responsive and responsible bidder. To be considered responsive, bidders must bid on all items.

**SEC. 4.14 CONTRACTOR SELECTION PROCESS**

Not applicable to this ITB.

**SEC. 4.15 NOTICE OF INTENT TO AWARD**

After the responses to this ITB have been opened and evaluated, a tabulation of the bids will be prepared. This tabulation, called a Notice of Intent to Award, serves two purposes. It lists the name of each company or person that offered a bid and the price they bid. It also provides notice of the state's intent to award a contract(s) to the bidder(s) indicated. A copy of the Notice of Intent will be sent to each company or person who responded to the ITB. Bidders identified as the apparent low responsive bidders are instructed not to proceed until a Purchase Order, Contract Award, Lease, or some other form of written notice is given by the procurement officer. A company or person who proceeds prior to receiving a Purchase Order, Contract Award, Lease, or some other form of written notice from the procurement officer does so without a contract and at their own risk.

## SECTION 5. GENERAL PROCESS AND LEGAL INFORMATION

### SEC. 5.01 INFORMAL DEBRIEFING

When the contract is completed, an informal debriefing may be performed at the discretion of the procurement officer. If performed, the scope of the debriefing will be limited to the products provided or work performed by the contractor.

### SEC. 5.02 ALASKA BUSINESS LICENSE AND OTHER REQUIRED LICENSES

Prior to the award of a contract, a bidder must hold a valid Alaska business license. However, to receive the Alaska Bidder Preference and other related preferences, such as the Alaska Veteran Preference and Alaskans with Disabilities Preference, a bidder must hold a valid Alaska business license prior to the deadline for receipt of bids. Bidders should contact the **Department of Commerce, Community and Economic Development, Division of Corporations, Business, and Professional Licensing, PO Box 110806, Juneau, Alaska 99811-0806**, for information on these licenses. Acceptable evidence that the bidder possesses a valid Alaska business license may consist of any one of the following:

- copy of an Alaska business license,
- certification on the bid that the bidder has a valid Alaska business license and has included the license number in the bid,
- a canceled check for the Alaska business license fee,
- a copy of the Alaska business license application with a receipt stamp from the state's occupational licensing office, or
- a sworn and notarized statement that the bidder has applied and paid for the Alaska business license.

You are not required to hold a valid Alaska business license at the time bids are opened if you possess one of the following licenses and are offering services or supplies under that specific line of business:

- fisheries business licenses issued by Alaska Department of Revenue or Alaska Department of Fish and Game,
- liquor licenses issued by Alaska Department of Revenue for alcohol sales only,
- insurance licenses issued by Alaska Department of Commerce, Community and Economic Development, Division of Insurance, or
- Mining licenses issued by Alaska Department of Revenue.

Prior the deadline for receipt of bids, all bidders must hold any other necessary applicable professional licenses required by Alaska Statute.

### SEC. 5.03 AUTHORITY

This ITB is written in accordance with AS 36.30 and 2 AAC 12.

### SEC. 5.04 COMPLIANCE

In the performance of a contract that results from this ITB, the contractor must comply with all applicable federal, state, and borough regulations, codes, and laws; be liable for all required insurance, licenses, permits and bonds; and pay all applicable federal, state, and borough taxes.

**SEC. 5.05 SUITABLE MATERIALS, ETC.**

Unless otherwise specified in this ITB, all materials, supplies or equipment offered by a bidder shall be new, unused, and of the latest edition, version, model, or crop and of recent manufacture.

**SEC. 5.06 SPECIFICATIONS**

Unless otherwise specified in this ITB, product brand names or model numbers specified in this ITB are examples of the type and quality of product required and are not statements of preference. If the specifications describing an item conflict with a brand name or model number describing the item, the specifications govern. Reference to brand name or number does not preclude an offer of a comparable or better product, if full specifications and descriptive literature are provided for the product. Failure to provide such specifications and descriptive literature may be cause for rejection of the offer.

**SEC. 5.07 BRAND SPECIFIC**

Not applicable to this ITB.

**SEC. 5.08 ITEM UPGRADES**

The state reserves the right to accept upgrades to models on the basic contract when the upgrades improve the way the equipment operates or improve the accuracy of the equipment. Such upgraded items must be at the same price as the items in the basic contract.

**SEC. 5.09 WORKMANSHIP AND MATERIALS**

All work must be performed in a thorough and workmanlike manner and in accordance with current industry practices. The contractor will be held responsible for the quality of the service, maintenance, and inspections. Service, maintenance, and inspections that are improperly done will be redone, by the contractor, at the contractor's risk and expense.

**SEC. 5.10 CONTRACTOR SITE INSPECTION**

The state may conduct on-site visits to evaluate the bidder's capacity to perform the contract. A bidder must agree, at risk of being found non-responsive and having its bid rejected, to provide the state reasonable access to relevant portions of its work sites. Individuals designated by the procurement officer at the state's expense will make site inspection.

**SEC. 5.11 ORDER DOCUMENTS**

Except as specifically allowed under this ITB, an ordering agency will not sign any vendor contract. The state is not bound by a vendor contract signed by a person who is not specifically authorized to sign for the state under this ITB. Unless otherwise specified in this ITB, the State of Alaska Purchase Order, Contract Award and Delivery Order are the only order documents that may be used to place orders against the contract(s) resulting from this ITB.

**SEC. 5.12 HUMAN TRAFFICKING**

By signature on their bid, the bidder certifies that the bidder is not established and headquartered or incorporated and headquartered in a country recognized as Tier 3 in the most recent United States Department of State's Trafficking in Persons Report.

The most recent United States Department of State's Trafficking in Persons Report can be found at the following website: <http://www.state.gov/j/tip/>

Failure to comply with this requirement will cause the state to reject the bid as non-responsive or cancel the contract.

**SEC. 5.13 RIGHT OF REJECTION**

Bidders must comply with all the terms of the ITB, the State Procurement Code (AS 36.30), and all applicable local, state, and federal laws, codes, and regulations. The procurement officer may reject any bid that does not comply with all the material and substantial terms, conditions, and performance requirements of the ITB.

Bidders may not qualify the bid nor restrict the rights of the state. If a bidder does so, the procurement officer may determine the bid to be a non-responsive counteroffer and the bid may be rejected.

Minor informalities that:

- do not affect responsiveness,
- are merely a matter of form or format,
- do not change the relative standing or otherwise prejudice other bidders,
- do not change the meaning or scope of the ITB,
- are trivial, negligible, or immaterial in nature,
- do not reflect a material change in the work, or
- do not constitute a substantial reservation against a requirement or provision,

may be waived by the procurement officer.

The state reserves the right to refrain from making an award if it is determined to be in the state's best interest.

**A bid from a debarred or suspended bidder shall be rejected.**

**SEC. 5.14 STATE NOT RESPONSIBLE FOR PREPARATION COSTS**

The state will not pay any cost associated with the preparation, submittal, presentation, or evaluation of any bid.

**SEC. 5.15 DISCLOSURE OF BID CONTENTS**

All bid prices become public information at the bid opening. After the deadline for receipt of bids, all other bid material submitted become the property of the State of Alaska and may be returned only at the state's option. AS 40.25.110 requires public records to be open to reasonable inspection. All other bid information will be held in confidence during the evaluation process and prior to the time a Notice of Intent to Award is issued. Thereafter, bids will become public information.

The Office of Procurement and Property Management (OPPM), or their designee recognizes that some information a bidder submits might be confidential under the United States or the State of Alaska Constitution, a federal statute or regulation, or a State of Alaska statute: i.e., might be confidential business information (CBI). *See, e.g.*, article 1, section 1 of the Alaska Constitution; AS 45.50.910 – 45.50.945 (the Alaska Uniform Trade Secrets Act); *DNR v. Arctic Slope Regional Corp.*, 834 P.2d 134, 137-39 (Alaska 1991). For OPPM or their designee to treat information a bidder submits with its bid as CBI, the bidder must do the following when submitting their bid: (1) mark the specific information it asserts is CBI; and (2) for each discrete set of such information, identify, in writing, each authority the bidder asserts make the information CBI. If the bidder does not do these things, the information will become public after the Notice of Intent to Award is issued. If the bidder does these things, OPPM or their designee will evaluate the bidder's assertion upon receiving a request for the information. If OPPM or their designee reject the assertion, they will, to the extent permitted by federal and State of Alaska law, undertake reasonable measures to give the bidder an opportunity to object to the disclosure of the information.

**SEC. 5.16 ASSIGNMENTS**

Per 2 AAC 12.480, the contractor may not transfer or assign any portion of the contract without prior written approval from the procurement officer. Bids that are conditioned upon the state's approval of an assignment will be rejected as non-responsive.

**SEC. 5.17 FORCE MAJEURE (IMPOSSIBILITY TO PERFORM)**

The parties to a contract resulting from this ITB are not liable for the consequences of any failure to perform, or default in performing, any of its obligations under the contract, if that failure or default is caused by any unforeseeable Force Majeure, beyond the control of, and without the fault or negligence of, the respective party.

For the purposes of this ITB, Force Majeure will mean war (whether declared or not); revolution; invasion; insurrection; riot; civil commotion; sabotage; military or usurped power; lightning; explosion; fire; storm; drought; flood; earthquake; epidemic; quarantine; strikes; acts or restraints of governmental authorities affecting the project or directly or indirectly prohibiting or restricting the furnishing or use of materials or labor required; inability to secure materials, machinery, equipment or labor because of priority, allocation or other regulations of any governmental authorities.

**SEC. 5.18 DEFAULT**

In case of default by the contractor, for any reason whatsoever, the state may procure the goods or services from another source and hold the contractor responsible for any resulting excess cost and may seek other remedies under law or equity.

**SEC. 5.19 DISPUTES**

If the contractor has a claim arising in connection with the contract that it cannot resolve with the state by mutual agreement, it shall pursue the claim, if at all, in accordance with the provisions of AS 36.30.620 – AS 36.30.632.

**SEC. 5.20 SEVERABILITY**

If any provision of the contract or agreement is found to be invalid or declared by a court to be illegal or in conflict with any law, the validity of the remaining terms and provisions will not be affected; and the rights and obligations of the parties will be construed and enforced as if the contract did not contain the particular provision held to be invalid.

**SEC. 5.21 CONTRACT CANCELLATION**

- 1) The state reserves the right to cancel the contract at its convenience upon **30** calendar days written notice to the contractor. The state is only liable for payment in accordance with the payment provisions of this contract for supplies or services provide before the effective date termination.
- 2) By signature on their bid, the bidder certifies that they will not support or participate in a boycott of the State of Israel. Failure to comply with this requirement may cause the state to reject the bid as non-responsive or cancel the contract.

**SEC. 5.22 GOVERNING LAW; FORUM SELECTION**

A contract resulting from this ITB is governed by the laws of the State of Alaska. To the extent not otherwise governed by Section 5.15 of this ITB, any claim concerning the contract shall be brought only in the Superior Court of the State of Alaska and not elsewhere.



### SEC. 5.23 QUALIFIED BIDDERS

Per 2 AAC 12.875, unless provided for otherwise in the ITB, to qualify as a bidder for award of a contract issued under AS 36.30, the bidder must:

- 1) Add value in the contract by actually performing, controlling, managing, or supervising the services to be provided;  
or
- 2) Be in the business of selling and have actually sold on a regular basis the supplies that are the subject of the ITB.

If the bidder leases services or supplies or acts as a broker or agency in providing the services or supplies to meet these requirements, the procurement officer may not accept the bidder as a qualified bidder under AS 36.30.

### SEC. 5.24 FEDERALLY IMPOSED TARIFFS

Changes in price (increase or decrease) resulting directly from a new or updated federal tariff, excise tax, or duty, imposed after contract award may be adjusted during the contract period or before delivery into the United States via contract amendment.

- **Notification of Changes:** The contractor must promptly notify the procurement officer in writing of any new, increased, or decreased federal excise tax or duty that may result in either an increase or decrease in the contract price and shall take appropriate action as directed by the procurement officer.
- **After-imposed or Increased Taxes and Duties:** Any federal excise tax or duty for goods or services covered by this contract that was exempted or excluded on the contract award date but later imposed on the contractor during the contract period, as the result of legislative, judicial, or administrative action may result in a price increase provided:
  - a) The tax or duty takes effect after the contract award date and isn't otherwise addressed by the contract.
  - b) The contractor warrants, in writing, that no amount of the newly imposed federal excise tax or duty or rate increase was included in the contract price, as a contingency or otherwise.
- **After-relieved or Decreased Taxes and Duties:** The contract price shall be decreased by the amount of any decrease in federal excise tax or duty for goods or services under the contract, except social security or other employment [taxes](#), that the contractor is required to pay or bear, or does not obtain a refund of, through the contractor's fault, negligence, or failure to follow instructions of the procurement officer.
- **State's Ability to Make Changes:** The state reserves the right to request verification of federal excise tax or duty amounts on goods or services covered by this contract and increase or decrease the contract price accordingly.
- **Price Change Threshold:** No adjustment shall be made in the contract price under this clause unless the amount of the adjustment exceeds \$250.

**SEC. 5.25 PROTEST**

AS 36.30.560 provides that an interested party may protest the content of the ITB.

An interested party is defined in 2 AAC 12.990(a) (7) as "an actual or prospective bidder or bidder whose economic interest might be affected substantially and directly by the issuance of a contract solicitation, the award of a contract, or the failure to award a contract."

If an interested party wishes to protest the content of a solicitation, the protest must be received, in writing, by the procurement officer at least ten days prior to the deadline for receipt of bids.

AS 36.30.560 also provides that an interested party may protest the award of a contract or the proposed award of a contract.

If a bidder wishes to protest the award of a contract or the proposed award of a contract, the protest must be received, in writing, by the procurement officer within ten days after the date the Notice of Intent to Award the contract is issued.

A protester must have submitted a bid to have sufficient standing to protest the proposed award of a contract. Protests must include the following information:

- the name, address, and telephone number of the protester,
- the signature of the protester or the protester's representative,
- identification of the contracting agency and the solicitation or contract at issue,
- a detailed statement of the legal and factual grounds of the protest including copies of relevant documents, and
- the form of relief requested.

Protests filed by telex or telegram are not acceptable because they do not contain a signature. Fax copies containing a signature are acceptable.

The procurement officer will issue a written response to the protest. The response will set out the procurement officer's decision and contain the basis of the decision within the statutory time limit in AS 36.30.580. A copy of the decision will be furnished to the protester by certified mail, fax or another method that provides evidence of receipt.

All bidders will be notified of any protest. The review of protests, decisions of the procurement officer, appeals, and hearings, will be conducted in accordance with the State Procurement Code (AS 36.30), Article 8 "Legal and Contractual Remedies."

## **SECTION 6. ATTACHMENTS**

### **SEC. 6.01 ATTACHMENTS**

**Attachments:**

- 1) ITB Cover Submittal Form
- 2) Appendix B<sup>2</sup>
- 3) Bid Schedule
- 4) Fire Retardant Storage Tank Design

## ATTACHMENT 1 BID SUBMISSION COVER SHEET

### PROJECT INFORMATION

ITB NUMBER: \_\_\_\_\_

PROJECT NAME: \_\_\_\_\_

### BIDDER INFORMATION

COMPANY NAME: \_\_\_\_\_

ADDRESS: \_\_\_\_\_

TAX ID: \_\_\_\_\_

ALASKA BUSINESS LICENSE #: \_\_\_\_\_

### CONTACT INFORMATION

Provide contact information for the individual that can be contacted for clarification regarding this bid:

NAME: \_\_\_\_\_

TITLE: \_\_\_\_\_

ADDRESS: \_\_\_\_\_

EMAIL: \_\_\_\_\_

TELEPHONE: \_\_\_\_\_

### ADDENDA ACKNOWLEDGEMENT

The bidder acknowledges receipt of the following amendments and has incorporated the requirements of such amendments into their bid. Failure to identify and sign for all amendments may subject the bidder to disqualification. The bidder must list all amendments (by number), then initial and date to confirm that you have received and incorporated them into your bid (add more rows as necessary).

Number	Initials & Date

Number	Initials & Date

Number	Initials & Date

**CERTIFICATIONS**

No	Criteria	Response*
1	The bidder is presently engaged in the business of providing the products and/or services required in this ITB.	<input type="checkbox"/> YES <input type="checkbox"/> NO
2	The bidder confirms that it has the financial strength to provide and/or perform and maintain the services required under this ITB.	<input type="checkbox"/> YES <input type="checkbox"/> NO
3	The bidder accepts the terms and conditions set out in the ITB and agrees not to restrict the rights of the state.	<input type="checkbox"/> YES <input type="checkbox"/> NO
4	The bidder confirms that they can obtain and maintain all necessary insurance as required on this project.	<input type="checkbox"/> YES <input type="checkbox"/> NO
5	The bidder certifies that all services provided under this contract by the contractor and all subcontractors shall be performed in the United States.	<input type="checkbox"/> YES <input type="checkbox"/> NO
6	The bidder is not established and headquartered or incorporated and headquartered, in a country recognized as Tier 3 in the most recent United States Department of State's Trafficking in Persons Report.	<input type="checkbox"/> YES <input type="checkbox"/> NO
7	The bidder complies with the American with Disabilities Act of 1990 and the regulations issued thereunder by the federal government.	<input type="checkbox"/> YES <input type="checkbox"/> NO
8	The bidder complies with the Equal Employment Opportunity Act and the regulations issued thereunder by the federal government.	<input type="checkbox"/> YES <input type="checkbox"/> NO
9	The bidder complies with the applicable portion of the Federal Civil Rights Act of 1964.	<input type="checkbox"/> YES <input type="checkbox"/> NO
10	The bidder can provide (if requested) financial records for the organization for the past three years.	<input type="checkbox"/> YES <input type="checkbox"/> NO
11	The bidder has not had any contracts terminated by the State of Alaska (within the past five years).	<input type="checkbox"/> YES <input type="checkbox"/> NO
12	The bidder certifies that it is not currently debarred, suspended, proposed for debarment, or declared ineligible for award by any public or federal entity.	<input type="checkbox"/> YES <input type="checkbox"/> NO
13	The offeror certifies that they will not support or participate in a boycott of Israel. Failure to comply with this requirement may cause the state to reject the proposal as non-responsive or cancel the contract.	<input type="checkbox"/> YES <input type="checkbox"/> NO
14	The bidder certifies that they do not have any governmental or regulatory action against their organization that might have a bearing on their ability to provide products and/or services to the State.	<input type="checkbox"/> YES <input type="checkbox"/> NO
15	The bidder certifies, within the last five years, they have not been convicted or had judgment rendered against them for: fraud, embezzlement, theft, forgery, bribery, falsification or destruction of records, false statements, or tax evasion.	<input type="checkbox"/> YES <input type="checkbox"/> NO
16	The bidder does not have any judgments, claims, arbitrations or suits pending/outstanding against your company in which an adverse outcome would be material to the company.	<input type="checkbox"/> YES <input type="checkbox"/> NO
17	The bidder is not (now or in the past) been involved in bankruptcy or reorganized proceeding.	<input type="checkbox"/> YES <input type="checkbox"/> NO
18	The bidder certifies they comply with the laws of the State of Alaska.	<input type="checkbox"/> YES <input type="checkbox"/> NO
19	The bidder confirms their bid will remain valid and open for at least 90 days.	<input type="checkbox"/> YES <input type="checkbox"/> NO

\* Failure to answer or answering "False" may be grounds for disqualification. For any "False" responses, provide clarification (up to 250 word maximum for each "False" clarification) below **(add rows as necessary)**.

Number	Clarification

**CONFLICT OF INTEREST STATEMENT**

Indicate below whether or not the firm or any individuals that will work on the contract has a possible conflict of interest (e.g., currently employed by the State of Alaska or formerly employed by the State of Alaska within the past two years) and, if so, the nature of that conflict. The procurement officer reserves the right to consider a bid non-responsive and reject it or cancel the award if any interest disclosed from any source could either give the appearance of a conflict or cause speculation as to the objectivity services to be provided by the bidder.

Does the bidder, or any individuals that will work on this contract, have a possible conflict of interest?

<input type="checkbox"/> YES <input type="checkbox"/> NO
--

*\* Failure to answer may be grounds for disqualification.*

If “Yes”, please provide additional information regarding the nature of that conflict:

**ALASKA PREFERENCES**

If you wish to claim any Alaska Preferences, please complete the Alaska Bidder Preference Certification Form that follows the below signature section.

**SIGNATURE**

This bid must be signed by a company officer empowered to bind the company.

Printed Name \_\_\_\_\_

Title \_\_\_\_\_

Date \_\_\_\_\_

Signature \_\_\_\_\_

## PREFERENCE CERTIFICATION FORM

### AS 36.30.321 (A) / AS 36.30.990 (2)

<b>Solicitation Number</b>	
<b>Project Description</b>	
<b>Business Name</b>	
<b>Alaska Business License Number</b>	

A signed copy of this form must be included with your bid or proposal no later than the deadline set for receipt of bids or proposals.

**If the procuring agency is unable to verify a response, the preference may not be applied.** Knowingly or intentionally making false or misleading statements on this form, whether it succeeds in deceiving or misleading, constitutes misrepresentation per [AS 36.30.687](#) and may result in criminal penalties.

### **SIGNATURE**

By signature below, I certify under penalty of law that I am an authorized representative of the above entity and all information on this form is true and correct to the best of my knowledge.

<b>Printed Name:</b>	
<b>Title:</b>	
<b>Date:</b>	
<b>Signature:</b>	

<b>Alaska Bidder Preference:</b> Do you believe your firm qualifies for the Alaska Bidder Preference?	<input type="checkbox"/> Yes <input type="checkbox"/> No
<b>Alaska Veterans Preference:</b> Do you believe your firm qualifies for the Alaska Veteran Preference?	<input type="checkbox"/> Yes <input type="checkbox"/> No
<b>Alaska Military Skills Program Preference:</b> Do you believe your firm qualifies for the Alaska Military Skills Program Preference?	<input type="checkbox"/> Yes <input type="checkbox"/> No

To qualify for and claim the **Alaska Bidder Preference** you must answer **YES** to all questions in the Alaska Bidder Preference Question section below:

### Alaska Bidder Preference Questions

1	Does your business hold a current Alaska business license per AS 36.30.990(2)(A)?	<input type="checkbox"/> Yes <input type="checkbox"/> No
2	Is your business submitting a bid or proposal under the name appearing on the Alaska Business license identified above? Per AS36.30.990 (2)(B)?	<input type="checkbox"/> Yes <input type="checkbox"/> No
3	Has your business maintained a place of business within the state staffed by the bidder or offeror or an employee of the bidder or offeror for a period of six months immediately preceding the date of the bid or proposal per AS 36.30.990 (2)(C)?	<input type="checkbox"/> Yes <input type="checkbox"/> No

**Per AS 16.05.415(a) per 2AAC 12.990(b)(7), the bidder or offeror, or at least one employee of the bidder or offeror must be a resident of the state?**

1	Do you certify the bidder or offeror, or, at least one employee of the bidder or offeror is physically present in the state with the intent to remain in Alaska indefinitely and to make a home in the state per AS 16.05.415(a)(2)?	<input type="checkbox"/> Yes <input type="checkbox"/> No
2	Do you certify the resident(s) used to meet this requirement has maintained a domicile in Alaska for the 12 months immediately preceding the deadline set for receipt of bids or proposals per AS 16.05.415(a)(2)?	<input type="checkbox"/> Yes <input type="checkbox"/> No
3	Do you certify the resident(s) used to meet this requirement is only claiming residency in Alaska per AS 16.05.415(a)(3)?	<input type="checkbox"/> Yes <input type="checkbox"/> No

### Alaska Veterans Preference Questions:

To qualify for and claim the Alaska Veteran Preference, you must answer **YES** to the below questions as well as answer **YES** to all the questions in the Alaska Bidders Preference section above.

**Per AS36.30.321(F), is your business:**

1	A sole proprietorship owned by an Alaska veteran?	<input type="checkbox"/> Yes <input type="checkbox"/> No
2	A partnership under AS32.06 or AS32.11 and a majority of the members are Alaska veterans?	<input type="checkbox"/> Yes <input type="checkbox"/> No
3	A limited liability company organized under AS10.50 and a majority of the members are Alaska veterans?	<input type="checkbox"/> Yes <input type="checkbox"/> No
4	A corporation that is wholly owned by individuals, and a majority of the individuals are Alaska veterans?	<input type="checkbox"/> Yes <input type="checkbox"/> No

**Per AS36.30.321(F)(3), an “Alaska veteran” is defined as an individual who:**

A. Served in the:

- a. Armed forces of the United States, including a reserve unit of the United States armed forces; or
- b. Alaska Territorial Guard, The Alaska Army National Guard, the Alaska Air Nations Guards, or the Alaska Naval Militia; and,

B. Was separated from services under a condition that was not dishonorable.

4	Do you certify the individual(s) indicated in items 1-4 above meet this definition and can provide documentation of their service and discharge if necessary?	<input type="checkbox"/> Yes <input type="checkbox"/> No
---	---	--



**Alaska Military Skills Program Preference Questions**

To qualify for and claim the Alaska Military Skills Program Preference, you must answer **YES** to the below questions as well as answer **YES** to all the questions in the Alaska Bidder Preference section above.

**Per 36.30.321(I), does your business:**

1	Employ at least one person who is enrolled in, or within the past two years, graduated from, a United States Department of Defense SkillBridge or United States Army career skills program that offers civilian work experience through specific industry training, pre-apprenticeships, registered apprenticeships, or internships during the last 180 days before a service member separates or retires from the service; or during the last 180 days before a the person separates or retires from the service?	<input type="checkbox"/> Yes <input type="checkbox"/> No
2	Have an active partnership with an entity that employs an apprentice through a program described in item 1 above?	<input type="checkbox"/> Yes <input type="checkbox"/> No
3	Have proof of an employee's graduation or enrollment in a qualified program as described in 1. above?	<input type="checkbox"/> Yes <input type="checkbox"/> No

**ATTACHMENT 2****APPENDIX B<sup>2</sup>****INDEMNITY AND INSURANCE****Article 1. Indemnification**

The contractor shall indemnify, hold harmless, and defend the contracting agency from and against any claim of, or liability for error, omission or negligent act of the contractor under this agreement. The contractor shall not be required to indemnify the contracting agency for a claim of, or liability for, the independent negligence of the contracting agency. If there is a claim of, or liability for, the joint negligent error or omission of the contractor and the independent negligence of the contracting agency, the indemnification and hold harmless obligation shall be apportioned on a comparative fault basis. "Contractor" and "contracting agency", as used within this and the following article, include the employees, agents and other contractors who are directly responsible, respectively, to each. The term "independent negligence" is negligence other than in the contracting agency's selection, administration, monitoring, or controlling of the contractor and in approving or accepting the contractor's work.

**Article 2. Insurance**

Without limiting contractor's indemnification, it is agreed that contractor shall purchase at its own expense and maintain in force at all times during the performance of services under this agreement the following policies of insurance. Where specific limits are shown, it is understood that they shall be the minimum acceptable limits. If the contractor's policy contains higher limits, the state shall be entitled to coverage to the extent of such higher limits. Certificates of Insurance must be furnished to the contracting officer prior to beginning work and must provide for a notice of cancellation, non-renewal, or material change of conditions in accordance with policy provisions. Failure to furnish satisfactory evidence of insurance or lapse of the policy is a material breach of this contract and shall be grounds for termination of the contractor's services. All insurance policies shall comply with and be issued by insurers licensed to transact the business of insurance under AS 21.

**2.1 Workers' Compensation Insurance:** The Contractor shall provide and maintain, for all employees engaged in work under this contract, coverage as required by AS 23.30.045, and; where applicable, any other statutory obligations including but not limited to Federal U.S.L. & H. and Jones Act requirements. The policy must waive subrogation against the State.

**2.2 Commercial General Liability Insurance:** covering all business premises and operations used by the Contractor in the performance of services under this agreement with minimum coverage limits of \$300,000 combined single limit per claim.

**2.3 Commercial Automobile Liability Insurance:** covering all vehicles used by the Contractor in the performance of services under this agreement with minimum coverage limits of \$300,000 combined single limit per claim.

**2.4 Professional Liability Insurance:** covering all errors, omissions or negligent acts in the performance of professional services under this agreement. Limits required per the following schedule:

<b>Contract Amount</b>	<b>Minimum Required Limits</b>
Under \$100,000	\$300,000 per Claim / Annual Aggregate
\$100,000-\$499,999	\$500,000 per Claim / Annual Aggregate
\$500,000-\$999,999	\$1,000,000 per Claim / Annual Aggregate
\$1,000,000 or over	Refer to Risk Management

### ATTACHMENT 3 BID SCHEDULE

Bidders are to submit their bid using this Bid Schedule. Bidders that fail to complete this bid schedule shall be considered non-responsive and their bids rejected. Bid prices are to remain firm for the duration of the contract and are to include all costs associated with providing required services, including, but not limited to, direct expenses, payroll, supplies, equipment, overhead, and profit. The Total Cost shown on this form is the cost that will be used for evaluation and award purposes under this ITB.

Quantities shown are an estimate of the number of units that may be required. Numbers are estimates only and will be used only for evaluation and award purposes. The State does not guarantee a minimum or maximum number of services to be provided or dollar amount to be spent under any contract resulting from this ITB.

#### 1. Bid

ITEM	DESCRIPTION	ESTIMATED NO. OF SERVICES	UNIT COST PER SERVICE	EXTENDED COST
1.	Tank Fabrication	4	\$	\$
2.	Delivery and Installation at Tanacross Airfield	1	\$	\$
3.	Delivery and Installation at Kenai Municipal Airport	3	\$	\$
4.	<b>Company Name:</b>			
	Authorized Representative's Printed Name:			
	Authorized Representative's Signature:			
	Date Bid Schedule Signed:			

**ATTACHMENT 4  
FIRE RETARDANT STORAGE TANK DESIGN**

INTENTIONALLY LEFT BLANK

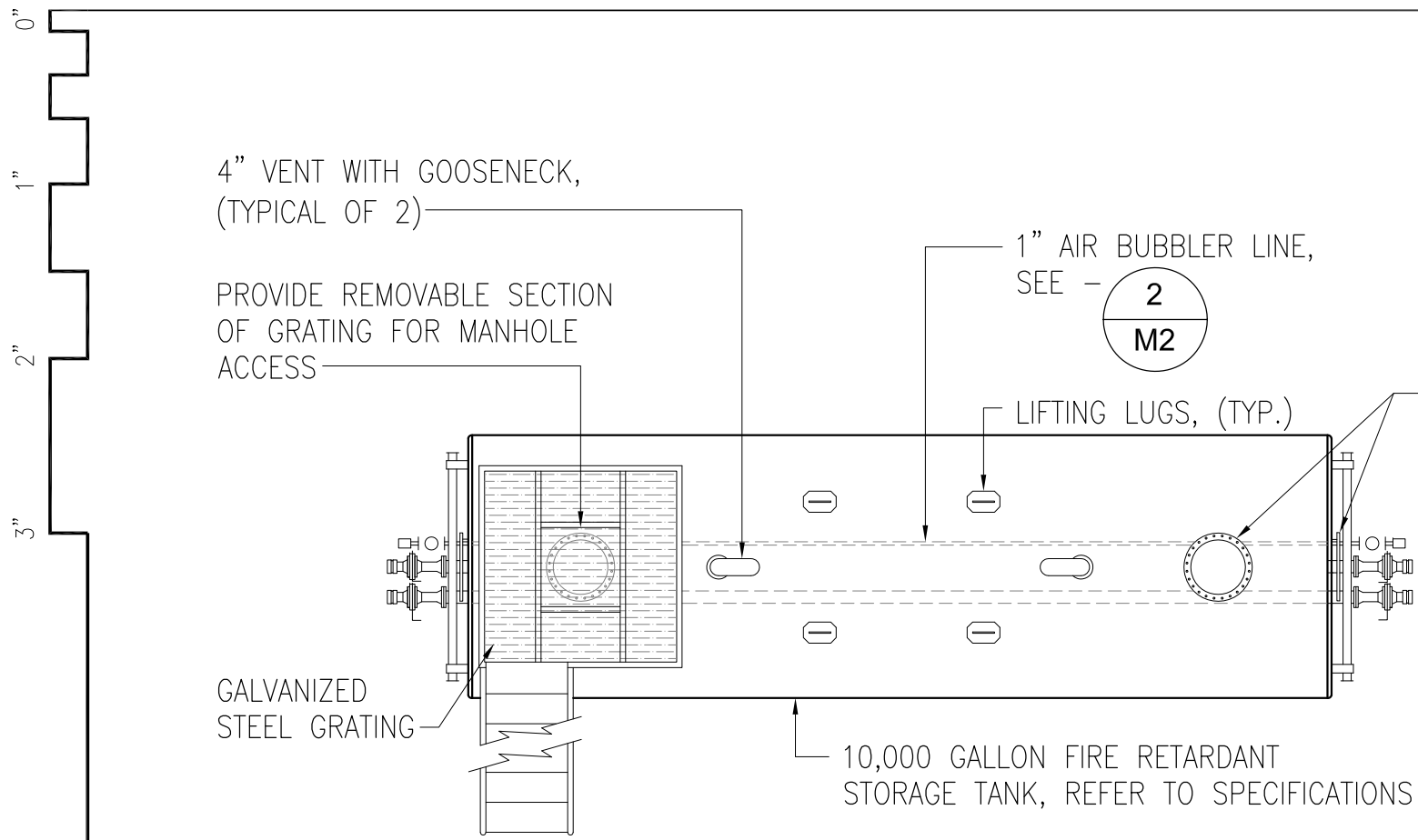

TOP VIEW

NOTES:  
 1. SANDBLAST EXTERIOR AND COAT WITH IRON OXIDE PRIMER WITH WHITE CHEMLINE POLYURETHANE PER MANUFACTURER SPECIFICATIONS AND PLUG ALL OPENINGS.  
 2. SANDBLAST INTERIOR AND COAT WITH DEVOE DEVMAT 111 PER MANUFACTURER SPECIFICATIONS.

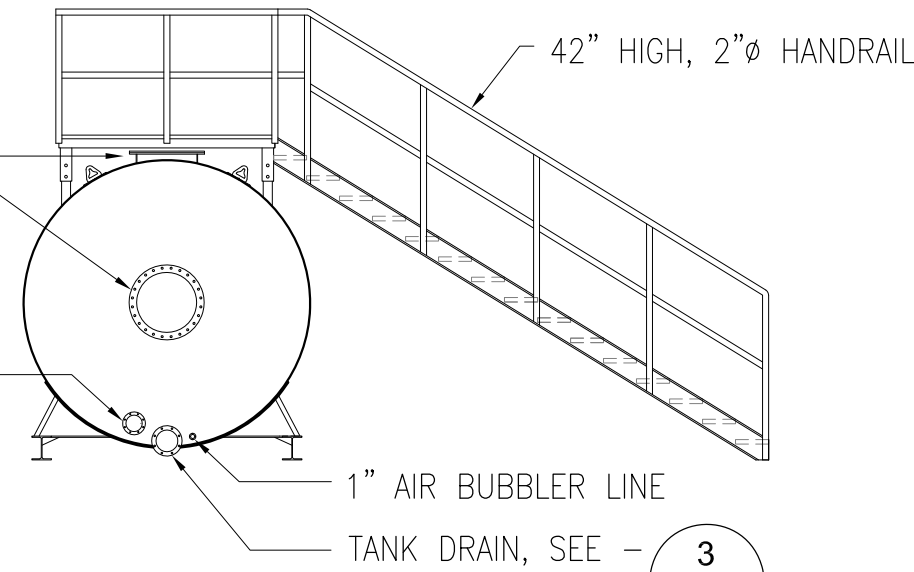

END VIEW  
(SKID SHOWN AS SECTION)

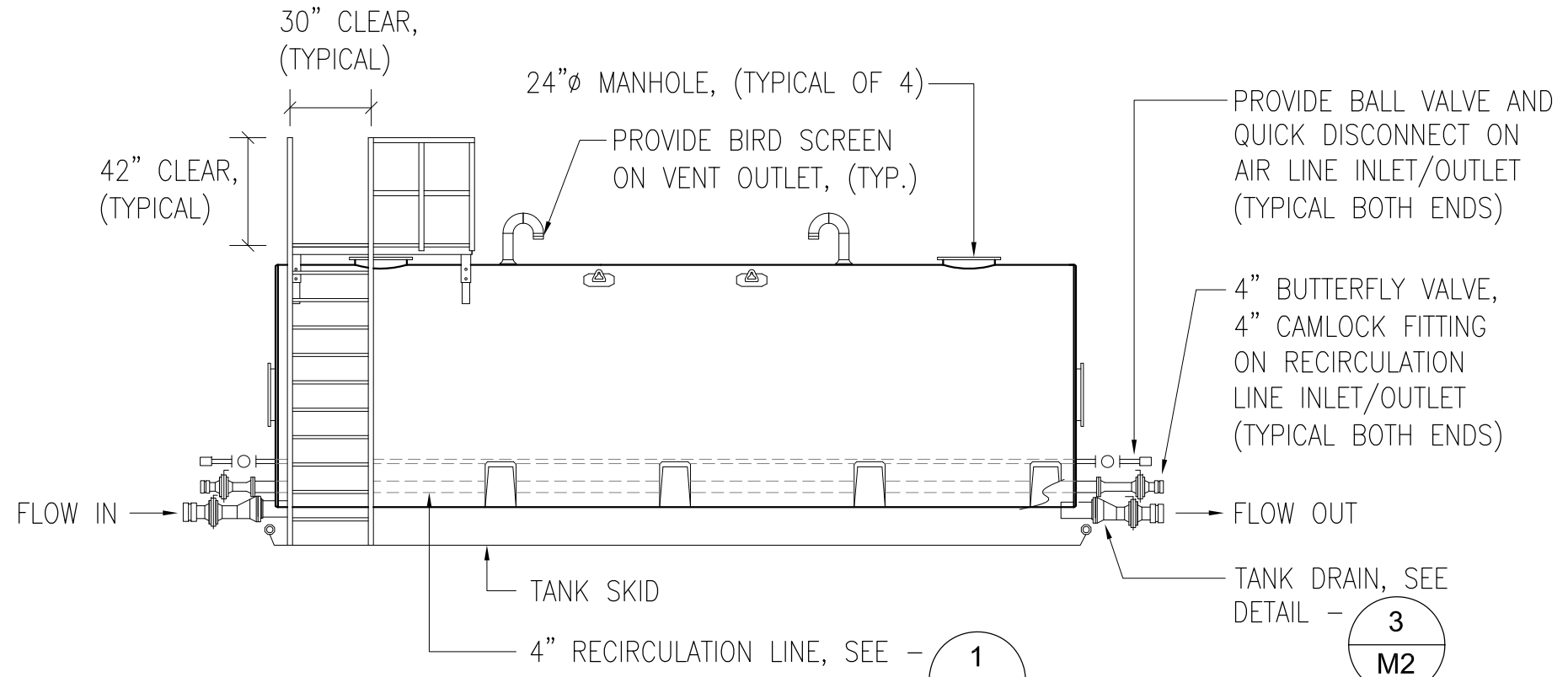

SIDE VIEW

DIMENSIONS	
DIAMETER	96"
LENGTH OF TANK	320"
LENGTH OVERALL	332"
CAPACITIES	
TANK (GALLONS)	10,034
MATERIALS	
TANK	1/4"
TANK HEAD	1/4"
SKID BEAMS	W8 x 35#
SADDLES	PL 3/16"
TOWBAR	4" SCHED 80
HEAD BRACE	C4 x 5.4
VENT SIZE	6"

**1 FIRE RETARDANT STORAGE TANK**  
N.T.S

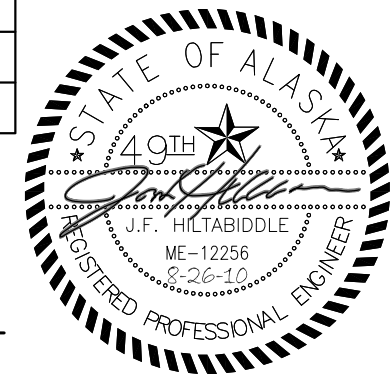

REVISIONS:

**RISA**  
**Engineering, Inc.**  
 MECHANICAL AND ELECTRICAL CONSULTING ENGINEERS  
 4533 Hildreth Street  
 Anchorage, Alaska 99504  
 Phone: (907) 276-0521  
 Fax: (907) 276-1121

**FIRE-RETARDANT STORAGE TANK DESIGN**

DRAWN BY: SR  
 CHECKED BY: JFH  
 DATE: 08/25/2010  
 JOB NUMBER: L0195  
 DWG FILE:

**M1**

# MECHANICAL SPECIFICATIONS

**WARRANTY** – ALL WORK PERFORMED UNDER THIS CONTRACT TO BE FREE FROM DEFECTS IN MATERIALS AND WORKMANSHIP FOR A PERIOD OF ONE YEAR FROM ACCEPTANCE. ANY FAULTY MATERIALS OR WORKMANSHIP SHALL BE REPAIRED OR REPLACED TO THE SATISFACTION OF THE OWNER DURING THE GUARANTEE PERIOD.

**MATERIALS** – ALL MATERIALS SHALL BE NEW AND UNUSED, INSTALLED IN ACCORDANCE WITH THE MANUFACTURER'S DIRECTIONS AND IN THE BEST PRACTICE OF THE CRAFT. OBTAIN OWNER'S APPROVAL OF ALL PRODUCTS PRIOR TO ORDERING OR INSTALLING ANY PART OF ANY SYSTEM.

**COMPRESSED AIR PIPING:** STEEL PIPE, ASTM A53, SCHEDULE 40 WITH THREADED FITTINGS. APPLY COATING AFTER DRILLING OF BUBBLER HOLES IN PIPING.

**RETARDANT RECIRCULATION PIPING:** STEEL PIPE, ASTM A53, SCHEDULE 40 WITH THREADED FITTINGS. APPLY COATING AFTER DRILLING OF RECIRCULATION HOLES.

**BUTTERFLY VALVES:** IRON BODY, BRONZE DISC, RESILIENT SEAT FOR-40 TO 120 F OPERATION, LUG ENDS AND 10 POSITION LEVER HANDLE.

**BALL VALVES:** BRONZE TWO PIECE BODY, FULL PORT, FORGED BRASS, CHROME PLATED BALL, TEFLON SEATS AND STUFFING BOX RING, LEVER HANDLE, THREADED ENDS WITH UNION. SEAT MATERIAL TO BE COMPATIBLE WITH FLUID HANDLED.

**OPERATION AND MAINTENANCE MANUAL** – PROVIDE THE OWNER WITH AN OPERATING AND MAINTENANCE MANUAL, TO INCLUDE MANUFACTURER'S SPECIFICATIONS, OPERATING AND MAINTENANCE INSTRUCTIONS, WARRANTY INFORMATION ON EACH PIECE OF EQUIPMENT, AS WELL AS A SOURCE OF SUPPLY FOR SPARE PARTS AND SERVICE.

**FIRE RETARDANT STORAGE TANK** – 10,000 GALLON CAPACITY, SHOP FABRICATED, WELDED STEEL TANK, MINIMUM STEEL GAUGE 2, SKID MOUNTED WITH MINIMUM OF 5 SADDLES, EXTERIOR COATING IRON OXIDE PRIMER WITH WHITE CHEMLINE POLYURETHANE PAINT. INTERIOR COATING ON SUITABLY PREPARED INTERIOR SURFACE WITH DEVOE DEVMAT 111 COATING. PROVIDE MANHOLES AND TAPPINGS AS INDICATED. SPECIAL ATTENTION SHALL BE PAID TO DRAIN CONNECTION AND INTERIOR PIPING REQUIREMENTS. STENCIL CONTENTS ON BOTH ENDS OF TANK IN MINIMUM 6" HIGH LETTERS "FIRE RETARDANT".

**STAIR/PLATFORM SPECIFICATIONS** – ALL STAIRS, HANDRAILS, GUARDRAILS, AND PLATFORMS SHALL BE CONSTRUCTED TO BE COMPLETELY COMPLIANT WITH O.S.H.A. AND ALL OTHER APPLICABLE CODES AND STANDARDS. THE STAIRS AND PLATFORM SHALL BE CONSTRUCTED SEPARATELY FROM THE TANK FOR SEPARATE SHIPPING AND FIELD CONNECTION TO TANK. STAIRS AND PLATFORMS SHALL BE OF WELDED STEEL CONSTRUCTION AND SHALL BE BOLTED TO MOUNTS WELDED TO THE TANK. ALL STAIRS AND PLATFORMS SHALL BE FINISHED SIMILAR TO THE EXTERIOR OF THE TANK WITH THE EXCEPTION OF STAIR TREADS AND PLATFORM GRATING. STAIR TREADS AND PLATFORM WALKWAY SHALL BE CONSTRUCTED OF GALVANIZED GRATING DESIGNED TO SUPPORT A MINIMUM LOAD OF 600 LBS. THE PLATFORM SHALL BE CONSTRUCTED WITH A REMOVABLE SECTION OF GRATING IN THE CENTER FOR MANHOLE ACCESS. THE PLATFORM DIMENSIONS SHALL BE A MINIMUM OF 6'-0" X 6'-0". HANDRAILS/GUARDRAILS SHALL HAVE A MINIMUM DIAMETER OF 2 INCHES. THE PLATFORM SHALL BE FRAMED WITH A MINIMUM OF 3 INCH C-CHANNEL.

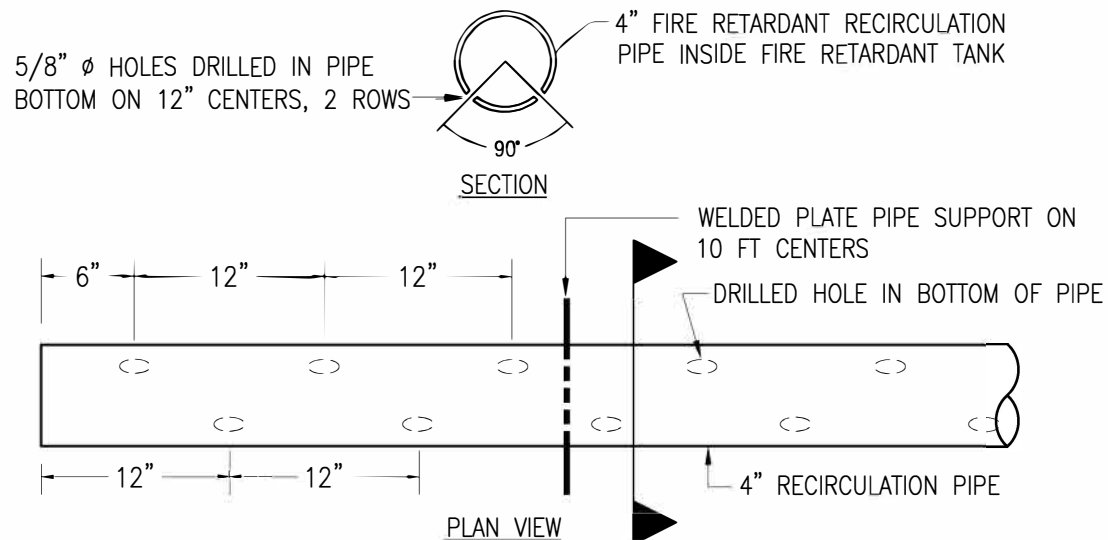

**1 FIRE RETARDANT RECIRCULATION LINE**  
N.T.S

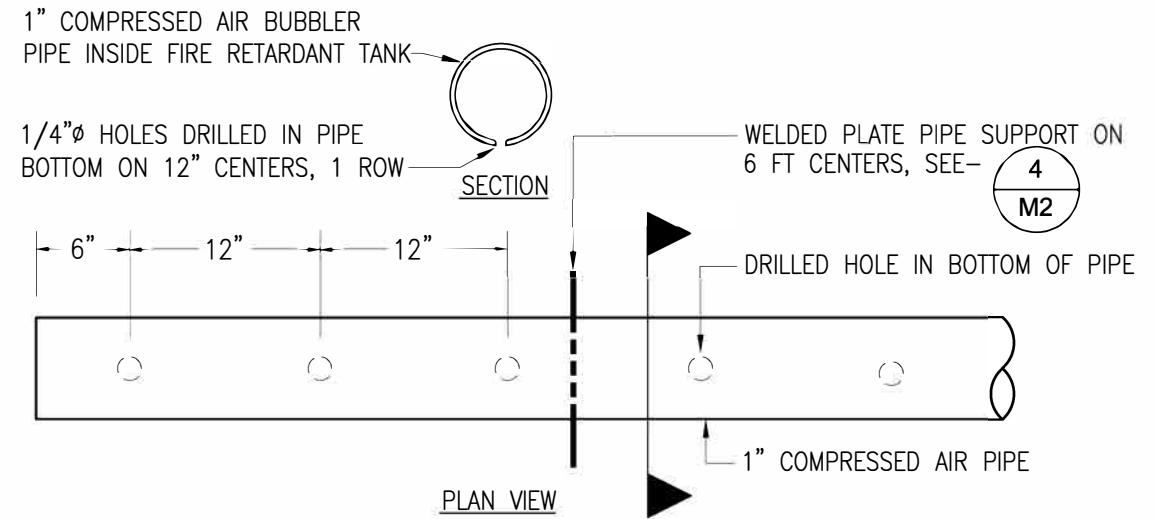

**2 COMPRESSED AIR BUBBLER LINE**  
N.T.S

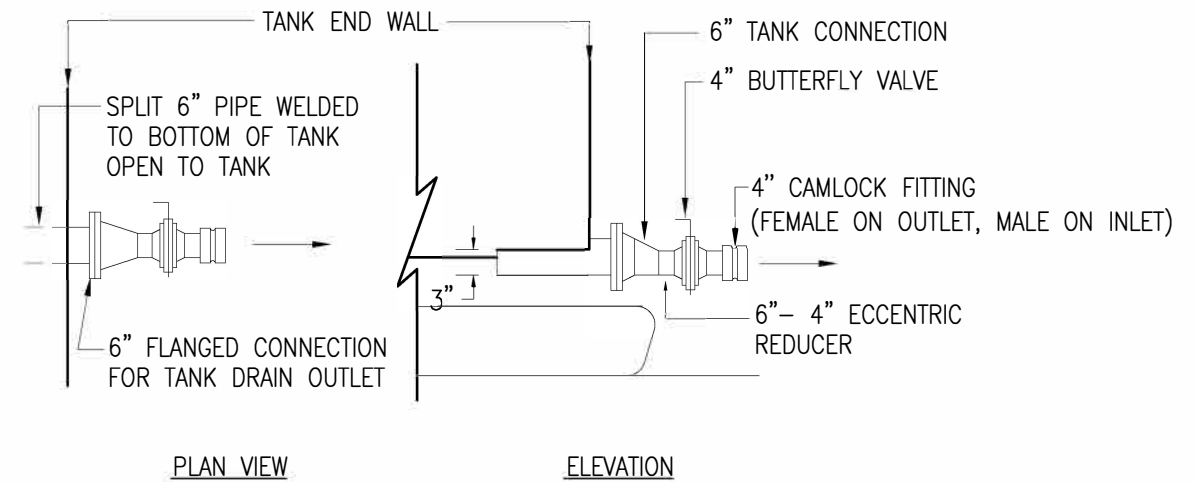

**3 TYPICAL TANK OUTLET/INLET DETAIL**  
N.T.S

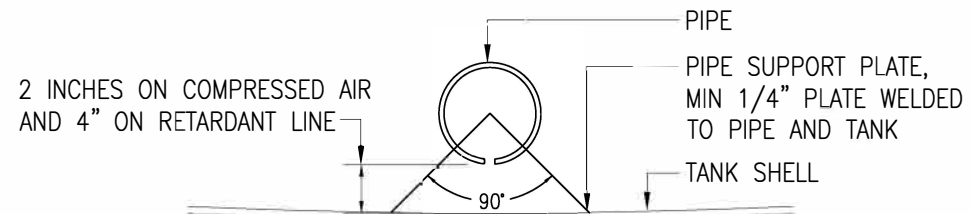

**4 INTERNAL TANK PIPE SUPPORT**  
N.T.S



REVISIONS:

**RISA Engineering, Inc.**  
MECHANICAL AND ELECTRICAL CONSULTING ENGINEERS  
1520 4th Ave. Ste. 100  
Anchorage, AK 99503  
Phone: (907) 275-0521  
Fax: (907) 275-1521

FIRE-RETARDANT STORAGE TANK DESIGN

DRAWN BY: SR  
CHECKED BY: JFH  
DATE: 08/26/2010  
JOB NUMBER: L0195  
DWG FILE:

M2

INTENTIONALLY LEFT BLANK