

KEY MAP



REGIONAL MAP

TIDAL DATA	
HTL	18.6'
MHW	13.2'
MLLW	0.0'
ELW	-5.5'

ADJACENT PROPERTY OWNERS:

STATE OF ALASKA, DNR
P.O. BOX 111020
JUNEAU, AK 99801

KOOTZNOOWOO, INC.
8585 OLD DAIRY ROAD
SUITE 104
JUNEAU, AK 99801

WATER BODIES:
KILLISNOO HARBOR, AK

KEY & REGIONAL MAPS

APPLICATION BY:

ALASKA STATE DEPT. OF TRANSPORTATION
AND PUBLIC FACILITIES
DESIGN & ENGINEERING SERVICES DIVISION
SOUTHCOAST REGION

**ANGOON FERRY TERMINAL
MODIFICATIONS**

PROJECT NO. SFHWY00466 / 0003288

AT: KILLISNOO HARBOR, ANGOON, ALASKA
IN: TOWNSHIP 51 SOUTH, RANGE 68 EAST,
SECTIONS 6 & 7, CRM
57D 28' 21.22" N, 134D 34' 02.48" W

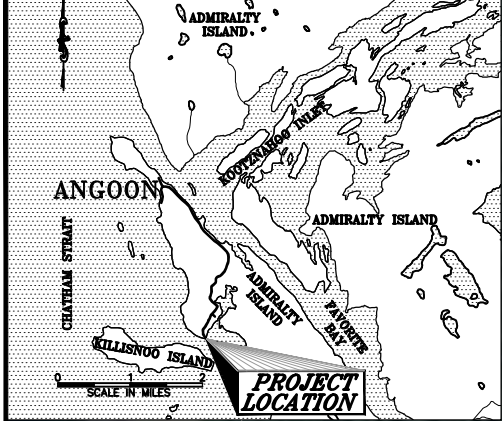

ADJACENT PROPERTY OWNERS:	
STATE OF ALASKA, DNR P.O. BOX 111020 JUNEAU, AK 99801	KOOTZNOOWOO, INC. 8585 OLD DAIRY ROAD SUITE 104 JUNEAU, AK 99801
WATER BODIES: KILLISNOO HARBOR, AK	

VICINITY MAP

APPLICATION BY:
ALASKA STATE DEPT. OF TRANSPORTATION
AND PUBLIC FACILITIES
DESIGN & ENGINEERING SERVICES DIVISION
SOUTHCOAST REGION

**ANGOON FERRY TERMINAL
MODIFICATIONS**
PROJECT NO. SFHWY00466 / 0003288

AT: KILLISNOO HARBOR, ANGOON, ALASKA
IN: TOWNSHIP 51 SOUTH, RANGE 68 EAST,
SECTIONS 6 & 7, CRM
57D 28' 21.22" N, 134D 34' 02.48" W

DATE: OCTOBER 2024 SHEET **2** OF **12**

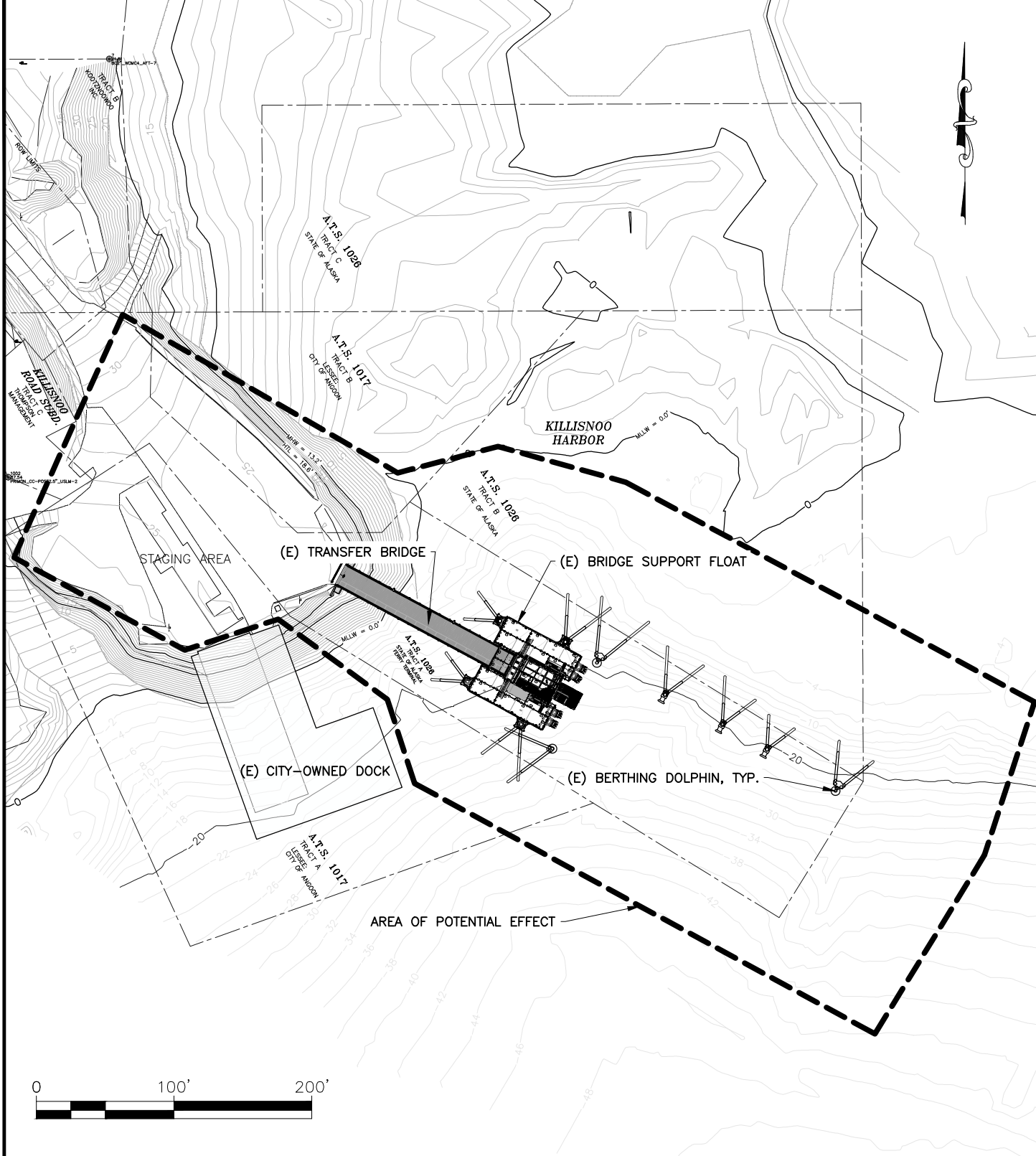

ADJACENT PROPERTY OWNERS:

STATE OF ALASKA, DNR
 P.O. BOX 111020
 JUNEAU, AK 99801

KOOTZNOOWOO, INC.
 8585 OLD DAIRY ROAD
 SUITE 104
 JUNEAU, AK 99801

WATER BODIES:

KILLISNOO HARBOR, AK

AREA OF POTENTIAL EFFECT

APPLICATION BY:

ALASKA STATE DEPT. OF TRANSPORTATION
 AND PUBLIC FACILITIES
 DESIGN & ENGINEERING SERVICES DIVISION
 SOUTHCOAST REGION

**ANGOON FERRY TERMINAL MODIFICATIONS
 PROJECT NO. SFHWY00466 / 0003288**

AT: KILLISNOO HARBOR, ANGOON, ALASKA
IN: TOWNSHIP 51 SOUTH, RANGE 68 EAST,
 SECTIONS 6 & 7, CRM
 57D 28' 21.22" N, 134D 34' 02.48" W

DATE: OCTOBER 2024

SHEET **3** OF **12**

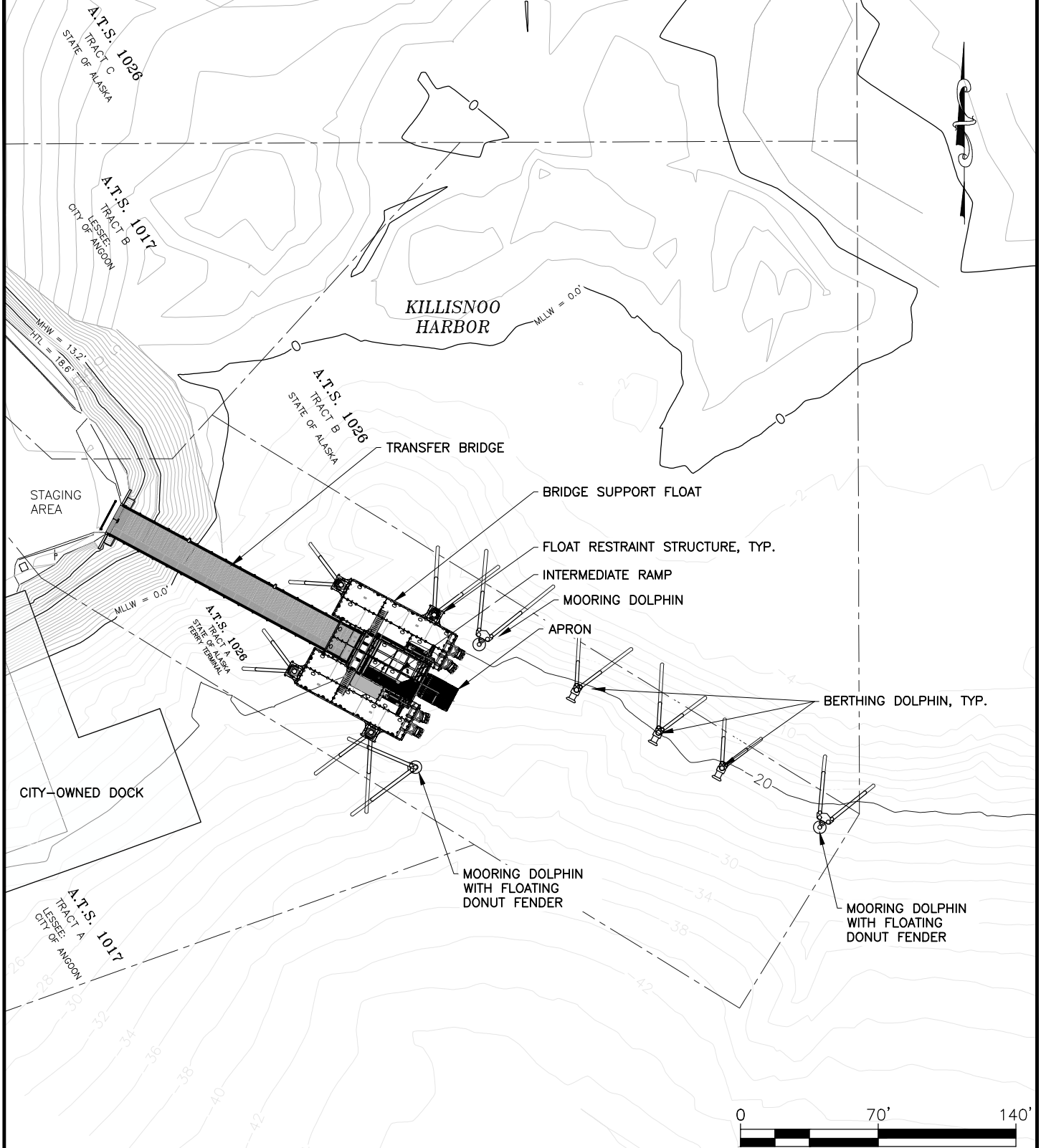

ADJACENT PROPERTY OWNERS:

STATE OF ALASKA, DNR P.O. BOX 111020 JUNEAU, AK 99801	KOOTZNOOWOO, INC. 8585 OLD DAIRY ROAD SUITE 104 JUNEAU, AK 99801
---	---

WATER BODIES:
KILLISNOO HARBOR, AK

EXISTING CONDITIONS

APPLICATION BY:

ALASKA STATE DEPT. OF TRANSPORTATION
AND PUBLIC FACILITIES
DESIGN & ENGINEERING SERVICES DIVISION
SOUTHCOAST REGION

**ANGOON FERRY TERMINAL
MODIFICATIONS
PROJECT NO. SFHWY00466 / 0003288**

AT: KILLISNOO HARBOR, ANGOON, ALASKA
IN: TOWNSHIP 51 SOUTH, RANGE 68 EAST,
SECTIONS 6 & 7, CRM
57D 28' 21.22" N, 134D 34' 02.48" W

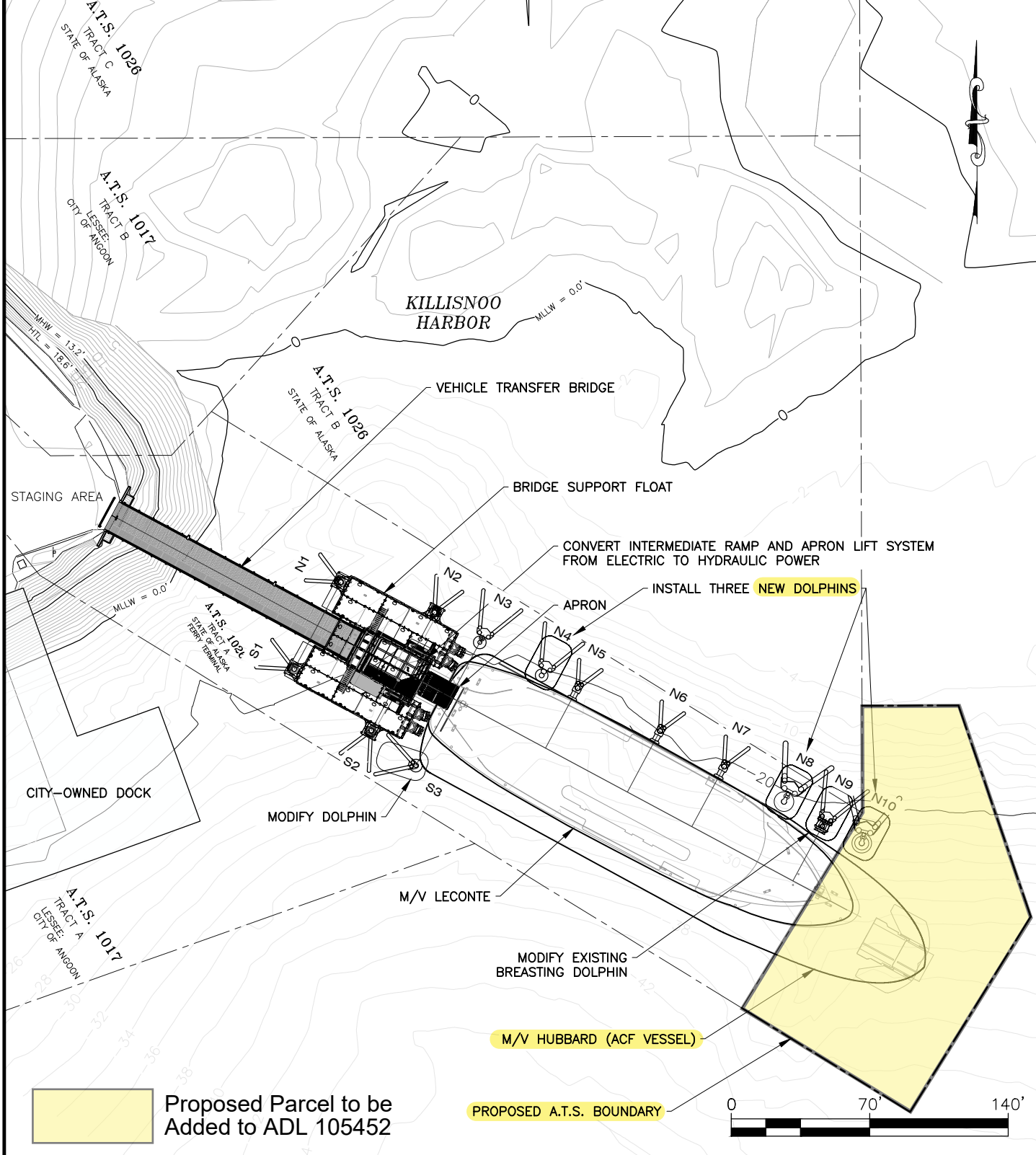

ADJACENT PROPERTY OWNERS:
 STATE OF ALASKA, DNR
 P.O. BOX 111020
 JUNEAU, AK 99801

KOOTZNOOWOO, INC.
 8585 OLD DAIRY ROAD
 SUITE 104
 JUNEAU, AK 99801

WATER BODIES:
 KILLISNOO HARBOR, AK

PROPOSED SITE PLAN

APPLICATION BY:
 ALASKA STATE DEPT. OF TRANSPORTATION
 AND PUBLIC FACILITIES
 DESIGN & ENGINEERING SERVICES DIVISION
 SOUTHCOAST REGION

ANGOON FERRY TERMINAL MODIFICATIONS

PROJECT NO. SFHWY00466 / 0003288

AT: KILLISNOO HARBOR, ANGOON, ALASKA
 IN: TOWNSHIP 51 SOUTH, RANGE 68 EAST,
 SECTIONS 6 & 7, CRM
 57D 28' 21.22" N, 134D 34' 02.48" W

DATE: OCTOBER 2024 SHEET **5** OF **12**

PILE DATA TABLE

STRUCTURE	PILE SIZE & DESIGNATION	ELEVATION (FT)			TENSION ANCHOR	ROCK SOCKET	ANODES	ESTIMATED LENGTH (FT)		
		ESTIMATED ORG. GROUND	ESTIMATED PILE TIP	CUTOFF				30x0.750	24x0.625	20x0.500
FLOATING FENDER DOLPHIN N4	30" FENDER PILE	-22	-75	+52.32	NO	YES	YES	137		
	24" VERTICAL L	-20	-65	+36.17	YES	NO	YES		111	
	24" VERTICAL R	-20	-65	+36.17	YES	NO	YES		111	
	24" BATTER L	-12	-80	+45.92	YES	NO	YES		143	
	24" BATTER R	-12	-80	+45.92	YES	NO	YES		143	
FLOATING FENDER DOLPHIN N8	30" FENDER PILE	-22	-55	+55.31	NO	YES	YES	120		
	30" VERTICAL L	-20	-45	+39.00	YES	NO	YES	94		
	30" VERTICAL R	-20	-45	+39.00	YES	NO	YES	94		
	30" BATTER L	-15	-45	+48.75	YES	NO	YES	109		
	30" BATTER R	-15	-45	+48.75	YES	NO	YES	109		
FLOATING FENDER DOLPHIN N10	30" FENDER PILE	-25	-50	+55.31	NO	YES	YES	115		
	30" VERTICAL L	-25	-40	+39.00	YES	NO	YES	89		
	30" VERTICAL R	-25	-40	+39.00	YES	NO	YES	89		
	30" BATTER L	-18	-35	+48.75	YES	NO	YES	99		
	30" BATTER R	-18	-35	+48.75	YES	NO	YES	99		
FLOATING FENDER DOLPHIN S3	24" FENDER PILE	-28	-60	+37.50	YES	NO	YES			108
	20" BATTER L	-35	-60	+43.50	YES	NO	YES			120
	20" BATTER R	-25	-60	+43.50	YES	NO	YES			120
UP TO 16 TEMPORARY PILES	UP TO 24" VERTICAL	-12 TO -25	-35 TO -80	VARIES	N/A					
TOTAL PILE LENGTH								1,155	509	347

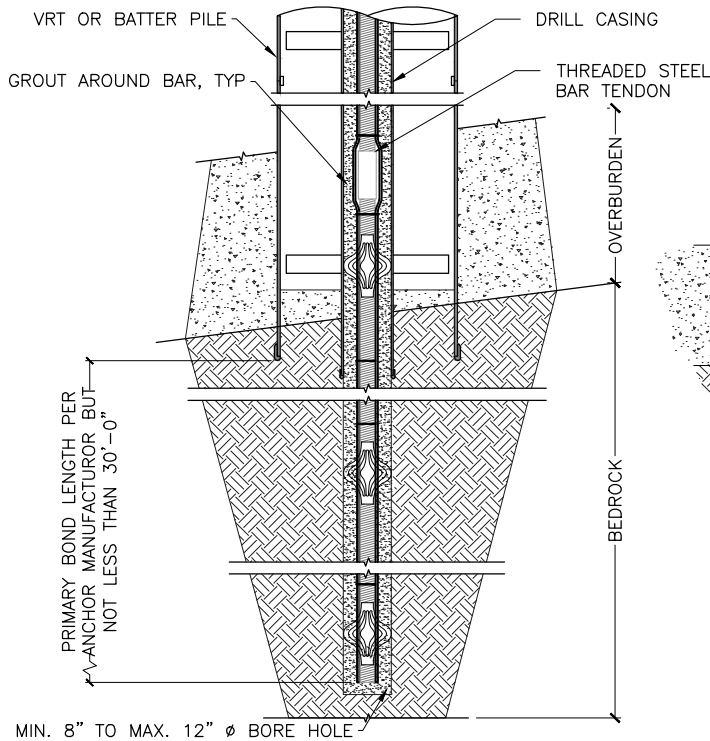

TENSION PILE ANCHOR

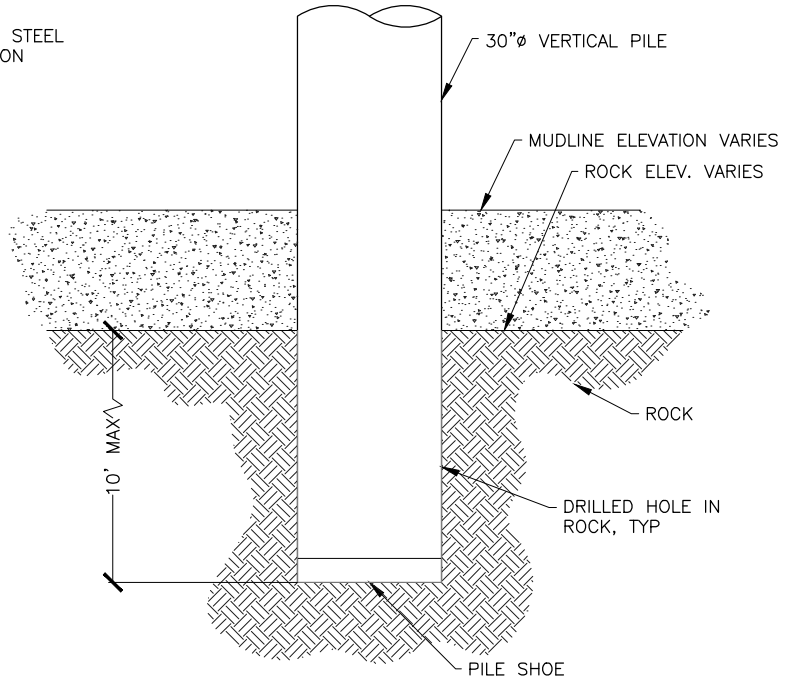

VERTICAL PILE ROCK SOCKET

ADJACENT PROPERTY OWNERS:

STATE OF ALASKA, DNR
P.O. BOX 111020
JUNEAU, AK 99801

KOOTZNOOWOO, INC.
8585 OLD DAIRY ROAD
SUITE 104
JUNEAU, AK 99801

WATER BODIES:

KILLISNOO HARBOR, AK

PILE DETAILS

APPLICATION BY:

ALASKA STATE DEPT. OF TRANSPORTATION
AND PUBLIC FACILITIES
DESIGN & ENGINEERING SERVICES DIVISION
SOUTHCOAST REGION

**ANGOON FERRY TERMINAL
MODIFICATIONS
PROJECT NO. SFHWY00466 / 0003288**

AT: KILLISNOO HARBOR, ANGOON, ALASKA
IN: TOWNSHIP 51 SOUTH, RANGE 68 EAST,
SECTIONS 6 & 7, CRM
57D 28' 21.22" N, 134D 34' 02.48" W

DATE: OCTOBER 2024

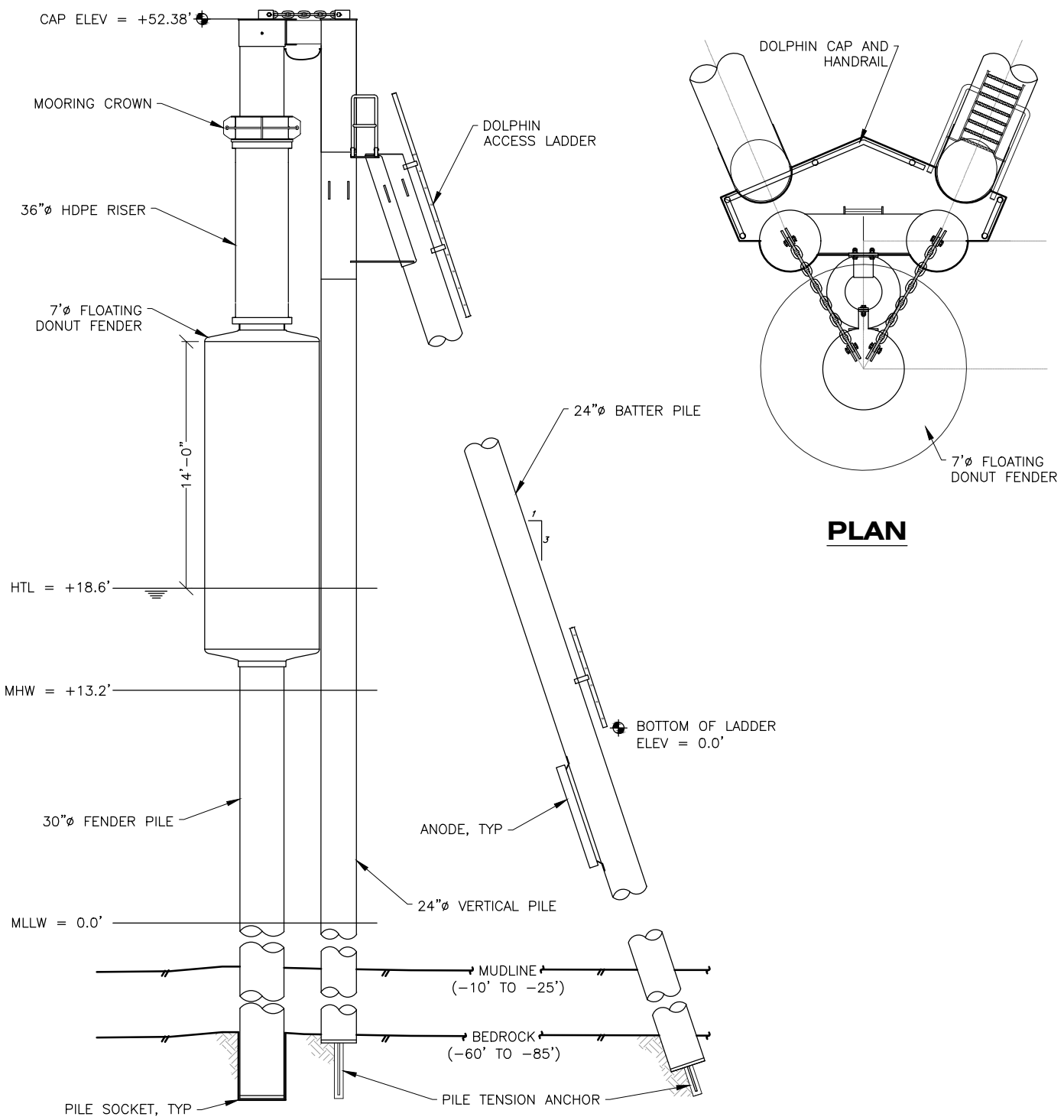

ELEVATION

PLAN

ADJACENT PROPERTY OWNERS:

STATE OF ALASKA, DNR
 P.O. BOX 111020
 JUNEAU, AK 99801

KOOTZNOOWOO, INC.
 8585 OLD DAIRY ROAD
 SUITE 104
 JUNEAU, AK 99801

WATER BODIES:
 KILLISNOO HARBOR, AK

DOLPHIN N4

APPLICATION BY:

ALASKA STATE DEPT. OF TRANSPORTATION
 AND PUBLIC FACILITIES
 DESIGN & ENGINEERING SERVICES DIVISION
 SOUTHCOAST REGION

**ANGOON FERRY TERMINAL
 MODIFICATIONS
 PROJECT NO. SFHWY00466 / 0003288**

AT: KILLISNOO HARBOR, ANGOON, ALASKA
IN: TOWNSHIP 51 SOUTH, RANGE 68 EAST,
 SECTIONS 6 & 7, CRM
 57D 28' 21.22" N, 134D 34' 02.48" W

DATE: OCTOBER 2024

CAP ELEV = +55.38'

MOORING CROWNS

36"Ø HDPE RISER

10'Ø FLOATING DONUT FENDER

14'-0"

HTL = +18.6'

MHW = +13.2'

30"Ø FENDER PILE

MLLW = 0.0'

PILE SOCKET, TYP

DOLPHIN CAP AND HANDRAIL

10'Ø FLOATING DONUT FENDER

PILE CUTOFF = +39.0'

PLAN

LADDER NOT SHOWN

30"Ø BATTER PILE

30"Ø VERTICAL PILE

ANODE, TYP

MUDLINE (-20' TO -25')

BEDROCK (-40' TO -45')

PILE TENSION ANCHOR, TYP

ELEVATION

ADJACENT PROPERTY OWNERS:

STATE OF ALASKA, DNR
P.O. BOX 111020
JUNEAU, AK 99801

KOOTZNOOWOO, INC.
8585 OLD DAIRY ROAD
SUITE 104
JUNEAU, AK 99801

WATER BODIES:

KILLISNOO HARBOR, AK

DOLPHIN N8

APPLICATION BY:

ALASKA STATE DEPT. OF TRANSPORTATION
AND PUBLIC FACILITIES
DESIGN & ENGINEERING SERVICES DIVISION
SOUTHCOAST REGION

ANGOON FERRY TERMINAL MODIFICATIONS

PROJECT NO. SFHWY00466 / 0003288

AT: KILLISNOO HARBOR, ANGOON, ALASKA
IN: TOWNSHIP 51 SOUTH, RANGE 68 EAST,
SECTIONS 6 & 7, CRM
57D 28' 21.22" N, 134D 34' 02.48" W

DATE: OCTOBER 2024

SHEET **8** OF **12**

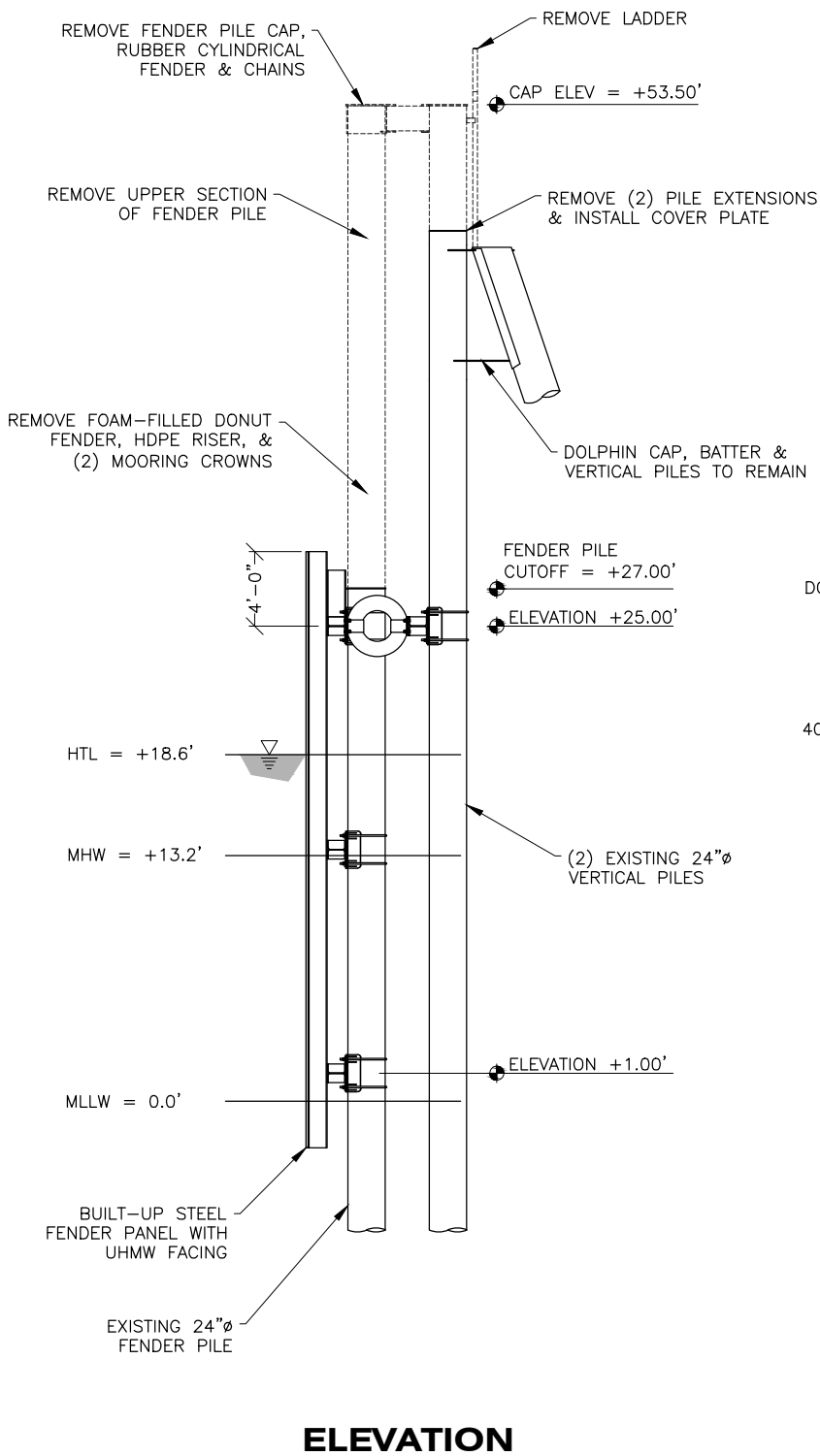

ELEVATION

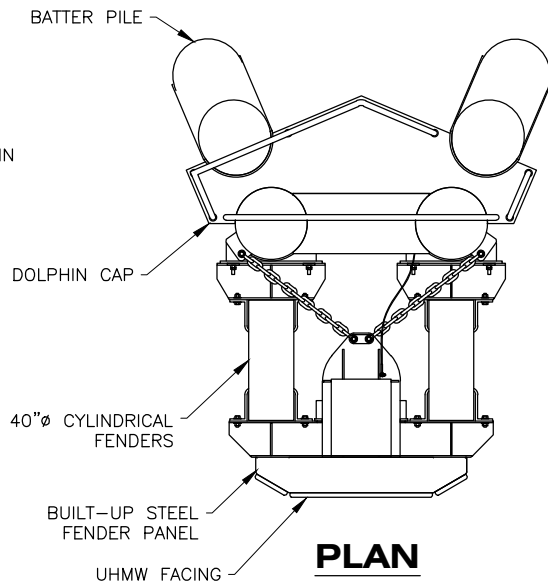

ADJACENT PROPERTY OWNERS:

STATE OF ALASKA, DNR
P.O. BOX 111020
JUNEAU, AK 99801

KOOTZNOOWOO, INC.
8585 OLD DAIRY ROAD
SUITE 104
JUNEAU, AK 99801

WATER BODIES:

KILLISNOO HARBOR, AK

DOLPHIN N9

APPLICATION BY:

ALASKA STATE DEPT. OF TRANSPORTATION
AND PUBLIC FACILITIES
DESIGN & ENGINEERING SERVICES DIVISION
SOUTHCOST REGION

**ANGOON FERRY TERMINAL
MODIFICATIONS**

PROJECT NO. SFHWY00466 / 0003288

AI: KILLISNOO HARBOR, ANGOON, ALASKA
IN: TOWNSHIP 51 SOUTH, RANGE 68 EAST,
SECTIONS 6 & 7, CRM
57D 28' 21.22" N, 134D 34' 02.48" W

DATE: OCTOBER 2024

SHEET **9** OF **12**

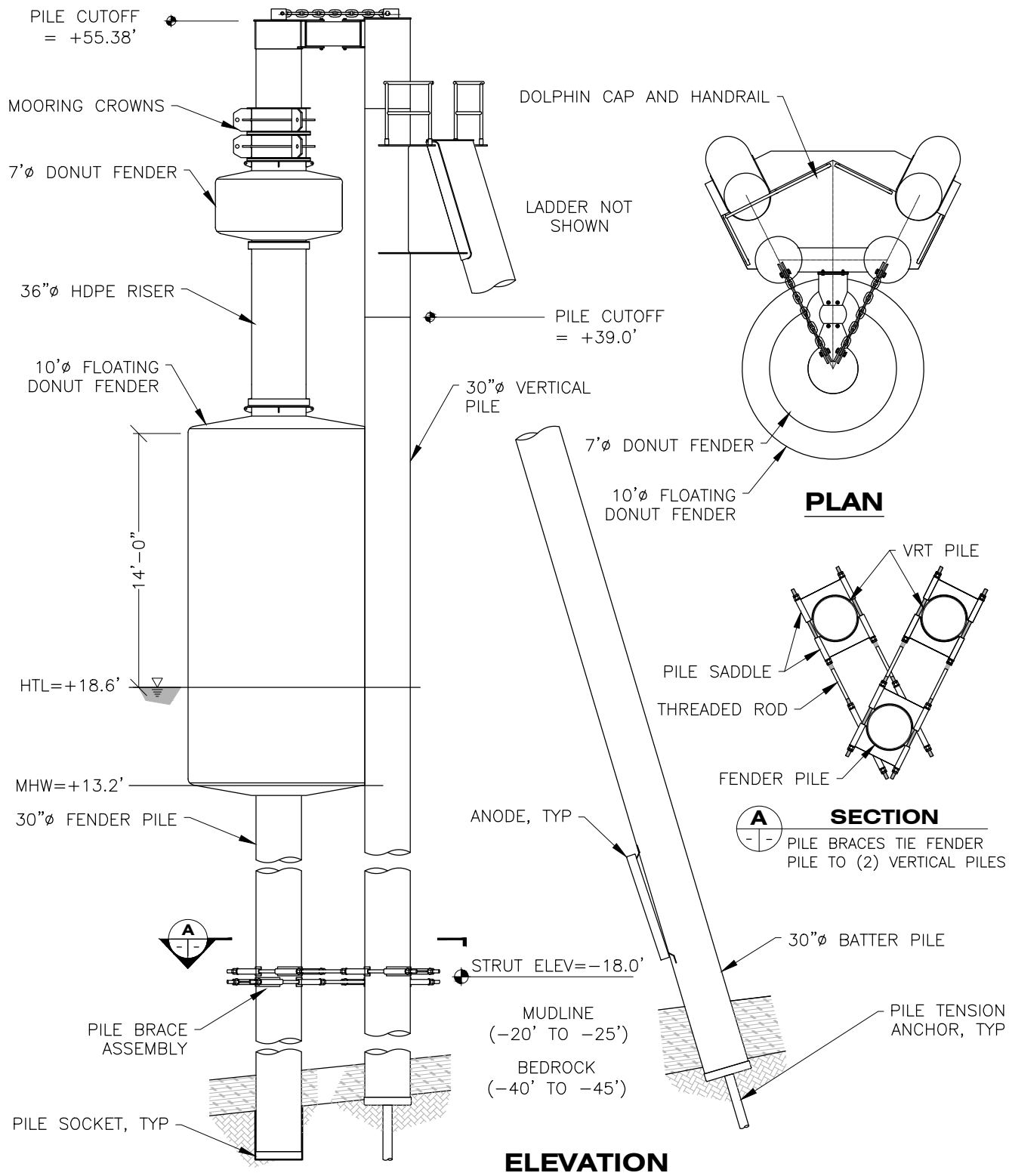

ADJACENT PROPERTY OWNERS:

STATE OF ALASKA, DNR
P.O. BOX 111020
JUNEAU, AK 99801

KOOTZNOOWOO, INC.
8585 OLD DAIRY ROAD
SUITE 104
JUNEAU, AK 99801

WATER BODIES:

KILLISNOO HARBOR, AK

DOLPHIN N10

APPLICATION BY:

ALASKA STATE DEPT. OF TRANSPORTATION
AND PUBLIC FACILITIES
DESIGN & ENGINEERING SERVICES DIVISION
SOUTHCOAST REGION

**ANGOON FERRY TERMINAL
MODIFICATIONS
PROJECT NO. SFHWY00466 / 0003288**

AT: KILLISNOO HARBOR, ANGOON, ALASKA
IN: TOWNSHIP 51 SOUTH, RANGE 68 EAST,
SECTIONS 6 & 7, CRM
57D 28' 21.22" N, 134D 34' 02.48" W

DATE: OCTOBER 2024

SHEET **10** OF **12**

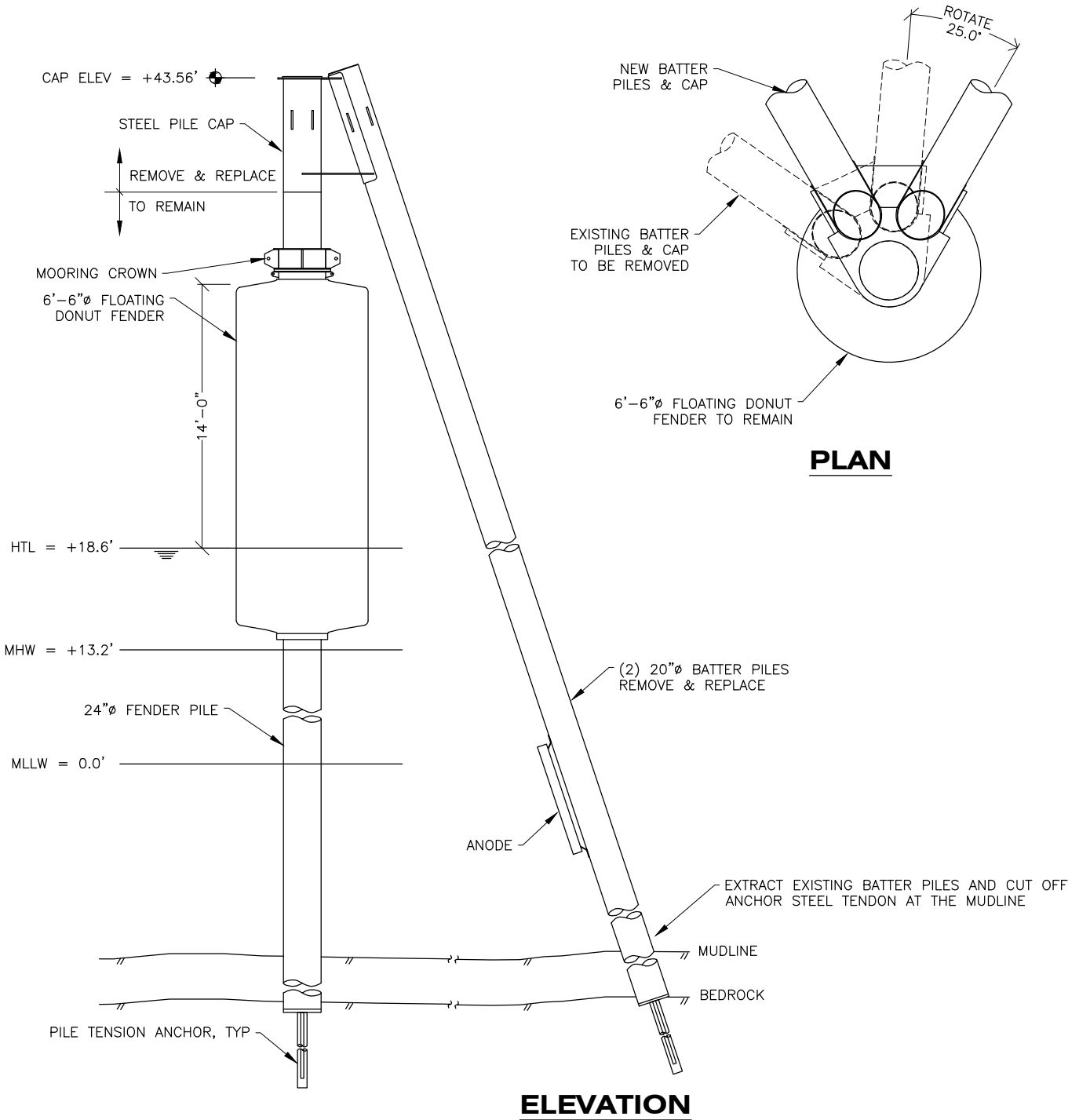

ADJACENT PROPERTY OWNERS:

STATE OF ALASKA, DNR
 P.O. BOX 111020
 JUNEAU, AK 99801

KOOTZNOOWOO, INC.
 8585 OLD DAIRY ROAD
 SUITE 104
 JUNEAU, AK 99801

WATER BODIES:

KILLISNOO HARBOR, AK

DOLPHIN S3

APPLICATION BY:

ALASKA STATE DEPT. OF TRANSPORTATION
 AND PUBLIC FACILITIES
 DESIGN & ENGINEERING SERVICES DIVISION
 SOUTHCOAST REGION

**ANGOON FERRY TERMINAL
 MODIFICATIONS**

PROJECT NO. SFHWY00466 / 0003288

AT: KILLISNOO HARBOR, ANGOON, ALASKA
IN: TOWNSHIP 51 SOUTH, RANGE 68 EAST,
 SECTIONS 6 & 7, CRM
 57D 28' 21.22" N, 134D 34' 02.48" W

DATE: OCTOBER 2024

SHEET **11** OF **12**

RAMP MODIFICATIONS:

1. REMOVE INTERMEDIATE RAMP ELECTRO-MECHANICAL ACTUATORS & REPLACE WITH HYDRAULIC CYLINDERS.
2. REMOVE APRON ELECTRO-MECHANICAL ACTUATORS & REPLACE WITH HYDRAULIC CYLINDERS.
3. AT CONTRACTOR'S OPTION, REPLACE APRON LIFT ASSEMBLY OR MAKE FIELD MODIFICATIONS.
4. INSTALL NEW HYDRAULIC POWER UNIT UNDER INTERMEDIATE RAMP.
5. ADD GATE TO LEFT SIDE OF INTERMEDIATE RAMP BARRIER. CLEAN FLOAT DECK OF DEBRIS.
6. POWER WASH APRON AND INSTALL NEW CLASPS TO UNDERSIDE OF APRON.
7. INSTALL NEW GATES ON INTERMEDIATE RAMP ON BOTH SIDES OF APRON.
8. FURNISH AND INSTALL NEW OBJECT MARKER SIGNS TO PLATFORM RAILING.

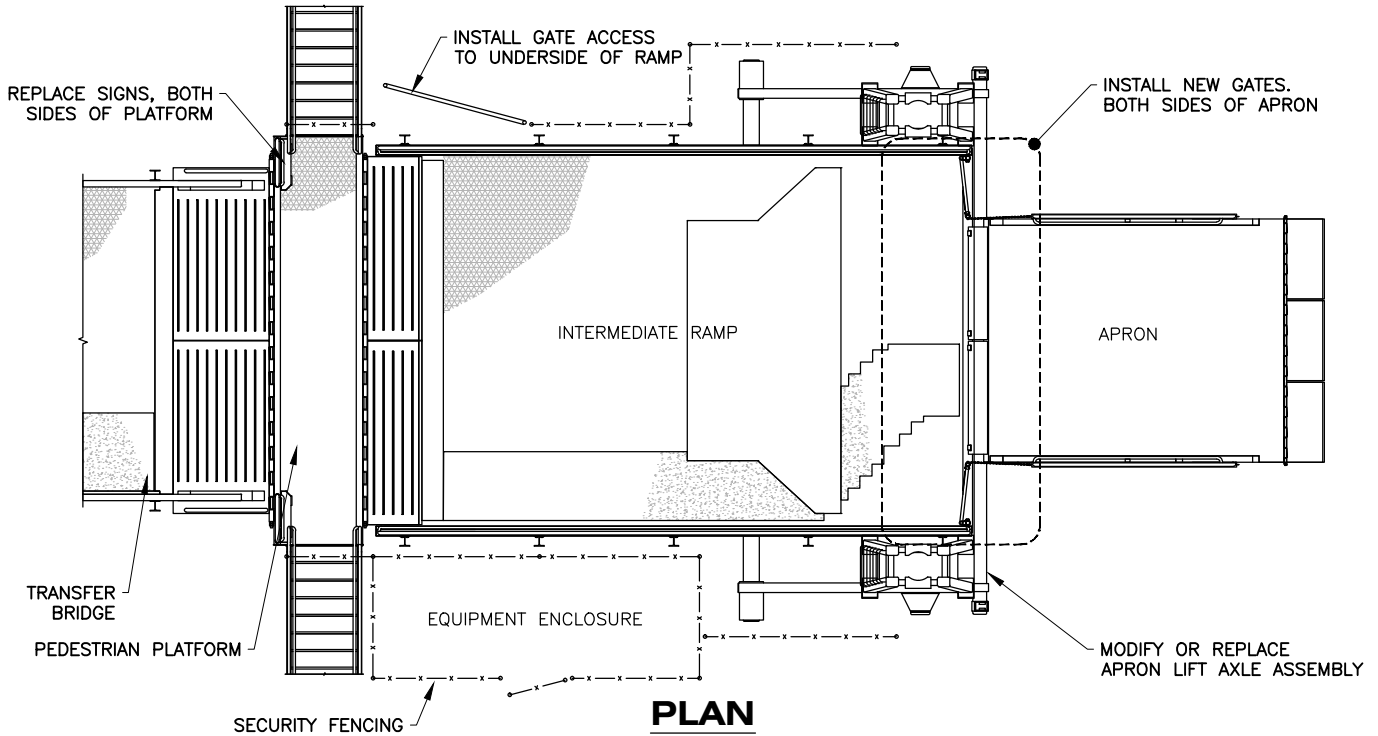

PLAN

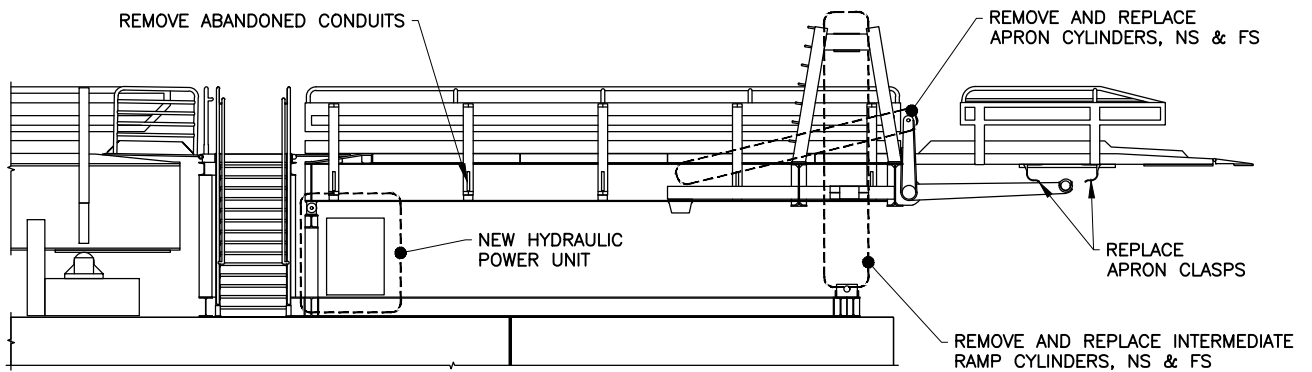

ELEVATION

ADJACENT PROPERTY OWNERS:

STATE OF ALASKA, DNR
P.O. BOX 111020
JUNEAU, AK 99801

KOOTZNOOWOO, INC.
8585 OLD DAIRY ROAD
SUITE 104
JUNEAU, AK 99801

WATER BODIES:

KILLISNOO HARBOR, AK

INTERMEDIATE RAMP & APRON MODIFICATIONS

APPLICATION BY:

ALASKA STATE DEPT. OF TRANSPORTATION
AND PUBLIC FACILITIES
DESIGN & ENGINEERING SERVICES DIVISION
SOUTHCOAST REGION

**ANGOON FERRY TERMINAL
MODIFICATIONS
PROJECT NO. SFHWY00466 / 0003288**

AT: KILLISNOO HARBOR, ANGOON, ALASKA
IN: TOWNSHIP 51 SOUTH, RANGE 68 EAST,
SECTIONS 6 & 7, CRM
57D 28' 21.22" N, 134D 34' 02.48" W

DATE: OCTOBER 2024

SHEET **12** OF **12**