

# **Exhibit 8**

## **System Pump Curve**



SYSTEM CURVE AND PUMP EVALUATION

FOR: **ROG Dredge** Dredge

Pipe Description: 12SDR11

Input Data:				Mark one Only
Discharge Side of the Pump:	<b>10</b>	Material:	<b>6</b>	
Line Length*	<b>300</b> Ft.			1
Inside Diameter	<b>10.3</b> Inches			2
Allowance for Ball Joints, Etc.	<b>5</b> Ft of Hd			3
Elevation of Discharge above Water	<b>30</b> Ft			4
Plastic(P) or Steel(S)	<b>p</b>			5
				6
Suction Side:				7
Line Length	<b>35</b>			8
Inside Diameter	<b>12</b> inches			9
Digging Depth	<b>25</b> Ft			10
Height of Pump above digging depth	<b>25</b> Ft			11
Impeller				
Impeller Size:	<b>25</b>	*Additional Discharge Input:		
RPM	647	Line Length	<b>0</b>	
Pulley/Transmission Ratio (X:1)	<b>2.65</b>	I.D.	<b>11</b>	
Pumping and Slurry Conditions:		Plastic(P) or Steel(S)	<b>p</b>	
Percent Solids by Weight	<b>25</b> Percent			0.02
Quantity	<b>5000</b> GPM			
Dry Solids	<b>0</b> Tons/Hr			
Specific Gravity of the Liquid	<b>1</b>			
Pumping Efficiency	<b>0.65</b>			
Calculations:				
Percent Solids by Volume	11.2	2.65 Sp. Gr. of Solids		
Specific Gravity of the Mix	1.184	1.28		
Tons per Hour of dry Solids	371	267.3 CuYds/Hr (approx)		
PPSI Minimum Suggested Velocity	<b>12.3</b> Ft/Sec	<b>MTI-Vcrit</b> <b>10.13</b> Ft/Sec		
Quantity	5,000 GPM			
Discharge Line velocity	19.3 Ft/Sec	Pipe Area 0.58 ft.^2		
Suction Line Velocity	14.2 Ft/Sec	Pipe Area 0.79 ft.^2		
Target Velocity	<b>14.7</b> Ft/Sec			
Head Required				
Discharge Pipe Friction	31 Ft.	1.85 Exponent		
Suction Pipe Friction	2.09 Ft.			
Entrance Losses	4 Ft.	Discharge Pressure Required:		
Sp. Gr. / D.D	5 Ft.	<b>2</b>		
Acceleration	6 Ft.			
Elevation	36 Ft.	Incoming Pressure:		
Other (Input)	5 Ft.	<b>0</b>		
Total Pump Hc	<b>93</b> Ft.	PSI:	<b>47</b>	
Horse Power Required	<b>213</b>	Est. Fuel Req'd	<b>8.9</b> Gals/Hr	
Engine RPM	<b>1714</b>	Discharge Pressure	<b>47</b>	
Impeller Tip Speed (FPM)	<b>4,233</b>	Recommend <	6600	

System Curve Table: Degree of Detail required **500**

Pressure (PSI)	Pump Head Feet	GPM	Pump HP Required	Head at pump Suction	Discharge Line Velocity	TPH dry solids Production	PUMP RPM
33	65	3000	90	-5.42	11.6	222.3	543
36	71	3500	114	-5.69	13.5	259.3	565
39	77	4000	142	-5.99	15.4	296.4	590
43	84	4500	175	-6.33	17.3	333.4	617
47	93	5000	213	-6.70	19.3	370.5	647
52	102	5500	258	-7.10	21.2	407.5	679
58	113	6000	311	-7.53	23.1	444.6	713
64	124	6500	372	-8.00	25.0	481.6	749
70	137	7000	443	-8.50	27.0	518.7	787

The data listed above is based on sound engineering theory and practice, but Pearce Pump Supply, Inc. is not responsible for any action taken on the basis of the above data or calculations.

# **Exhibit 9**

## **Generalized Process Flow Diagram**

# FLOW THROUGH DIAGRAM OF DREDGED MATERIAL

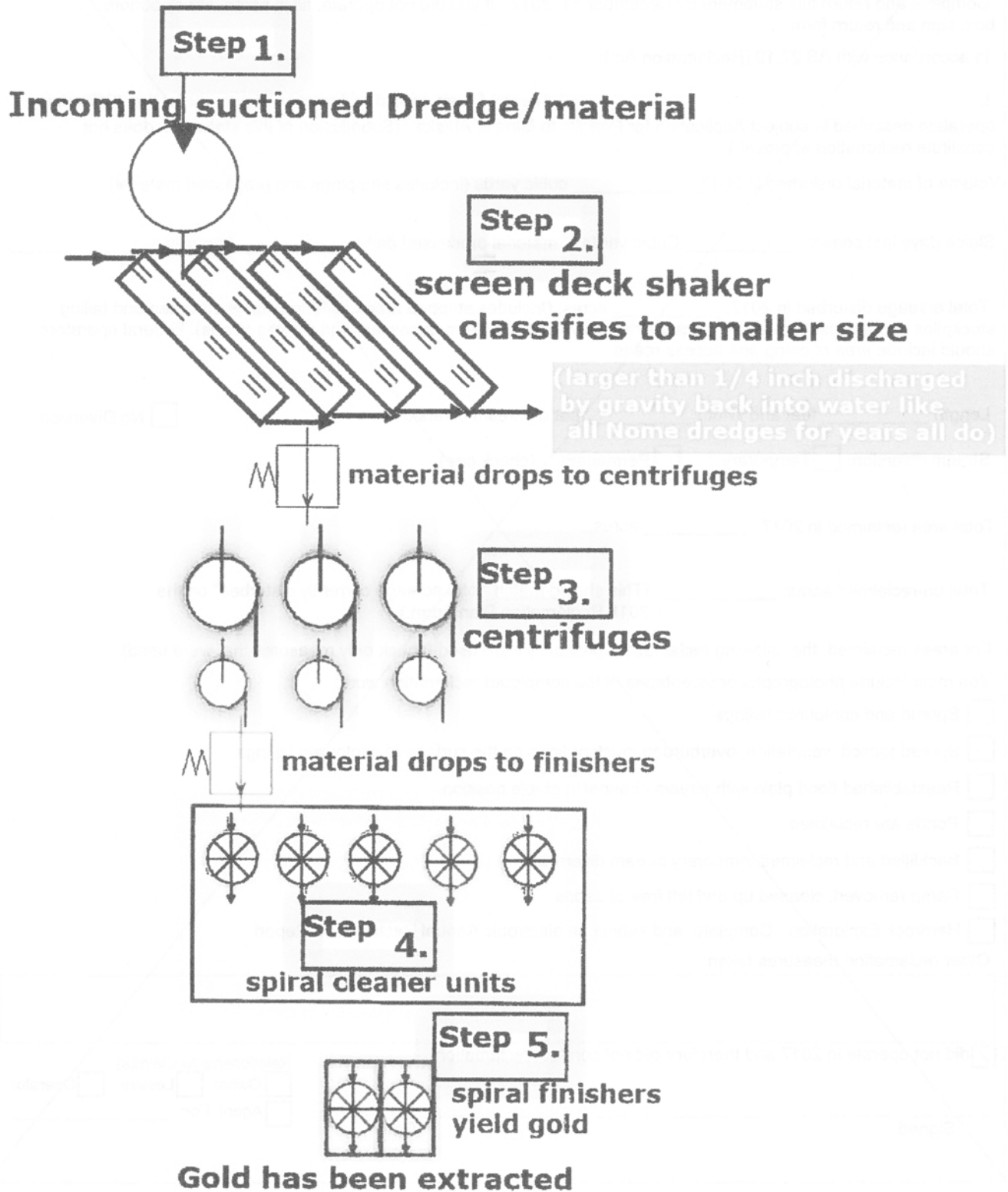

**Exhibit :**

**2018 Sediment Sampling and Drilling Results, Chains of Custody, Oro  
Industries Processing Results**

## Ezj kkw'/'Cuc{ 'Tgunnu

IPOP retrieved an initial, hand-dug sample from the northwest corner of the underwater portion of DSKN 31 on May 7, 2018, and had it analyzed by American Assay Laboratories of Sparks, NV. The results are attached hereto as Exhibit : A. This test confirmed what IPOP had been told by state regulators: that there was no appreciable mercury present in the area, and enabled IPOP to focus further laboratory work on mineralization tests of commercial interest.

IPOP has heretofore delayed releasing detailed results from its exploration sampling because the of desire to seek out additional potential claims without setting off a “gold rush”. IPOP sampled the cores in precisely the locations proposed, as set forth in the map previously provided:

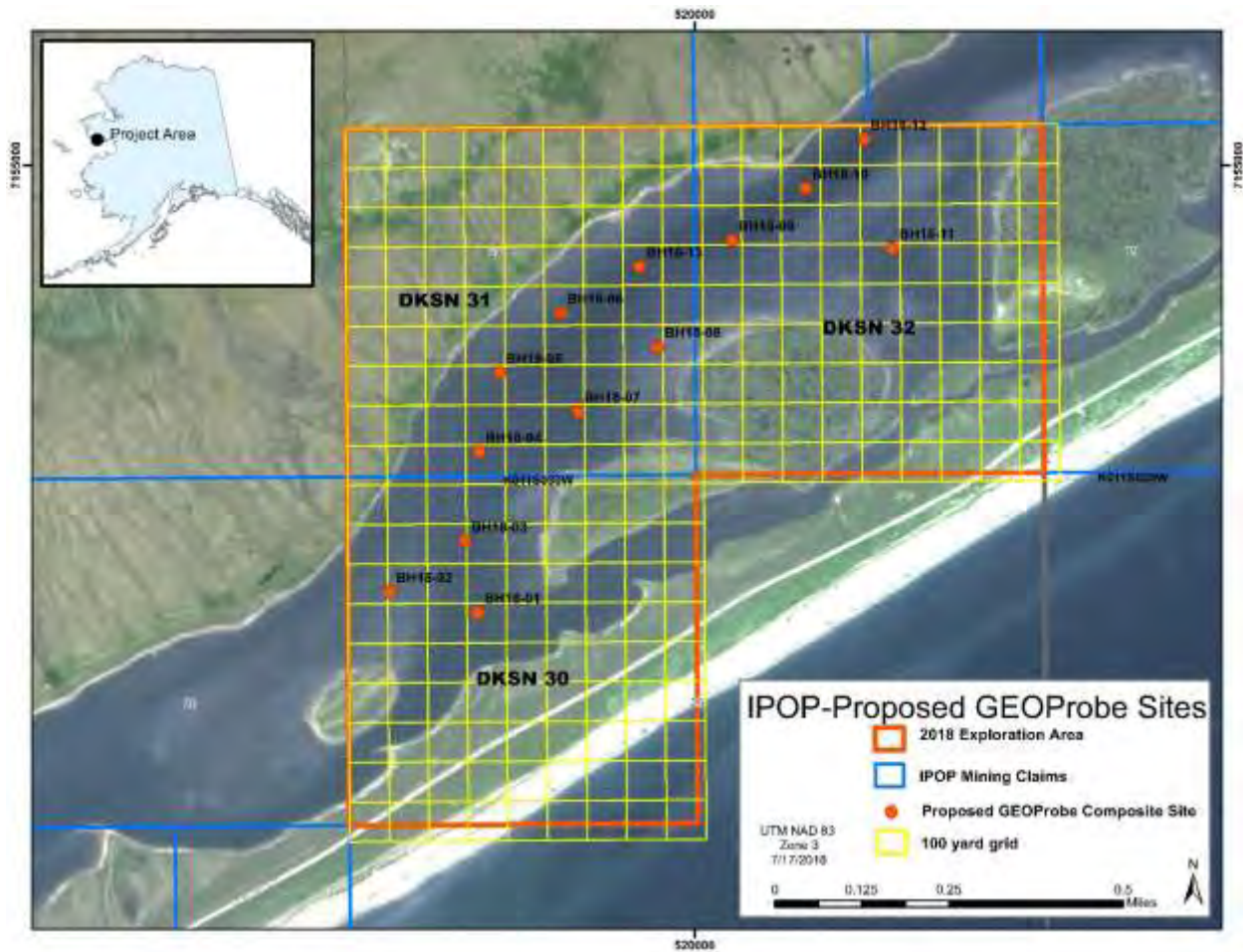

Exhibit : B shows the date and time thirteen samples were collected, with sample codes, and identifies the person who collected them and sent them to American Assay Laboratories, of Sparks, NV.

Attached as Exhibit : C is Final Report from American Assay Laboratories. They received the core samples and produced detailed information concerning both the mineral content of thirteen core samples (BH18-01 through -13), and the proportion of sand, silt and clay.<sup>1</sup>

<sup>1</sup> American Assay labs defines “clay” as having particle size less than two microns, “sand” as particle size greater than 63 microns, and “silt” as particle size two to sixty-three microns.

Because the core samples consisted of unconsolidated materials, unlike hard rock core samples, and were also relatively homogeneous, no detailed analysis of the composition by depth layer was conducted. The geologic lessons from the historically-rich Nome beaches demonstrate that the fine gold is widely distributed—no exercise like attempting to identify the location of lode formation is required in this context. What was more important was to confirm the congruence of the mineral composition results with the depositional layers of the gold rich beaches in Nome. More specifically, in Nome the best predictor of gold in the beach sands is the quartz percentage, and the core samples showed a very high percentage of quartz.

IPOP did not ask American Assay Laboratories to prepare detailed information concerning the precise portions of gold within the samples for two reasons. First, gold was obvious and pervasive in the cored samples, to the extent it could be seen through the cored clear plastic liner immediately when the cores were brought back to Nome:



Again, the obvious presence of gold like this comes as no surprise to IPOP, which extensively researched the history and geology of the area. Miners up the nearby rivers produced millions of ounces of gold, and the sediment in the Bonanza Channel comes out of these rivers and other upland gold deposits.

More importantly, IPOP's primary concern, given the generally small size of the gold particles, was to utilize the 323 lbs. of cored material in a batch test of IPOP's concentrating equipment, equipment which must be engineered to match the type of placer gold actually encountered.

Accordingly, after the testing by American Assay Laboratories, the samples were transferred under a strict chain of custody to Oro Industries of Placerville, California, who engineered the processing equipment. Ms. Claudia Wise picked up the core samples from the shipper at the American Assay Lab on June 4, 2019, and drove them to Oro Industries, arriving on June 5, 2019. Mr. Paul Clift of Oro Industries signed for the packages and they were unloaded. See Exhibits : D (receipts) & : E (photographs)

At this point, the samples were to be put through a large centrifuge; Mr. Clift could not wait to see the results, and began to hand-pan the material. (Exhibit : F). Some tests to see how quickly the material would settle were run, and the centrifuged concentrate was then fed into the spiral concentrator. Everyone was pleased with the results, which showed significant gold."

The net result was that the concentrators produced a total of seven grams of gold from the 323 lbs. of core samples. (Exhibit : I .) This is just over 43 grams of gold per ton, and far lower concentrations than this are commercially viable.



**EXHIBIT : A**

**SP0122408  
FINAL REPORT**

Multi Element Package

**Au  
ICP  
XRF**



AMERICAN ASSAY LABORATORIES  
1500 GLENDALE AVE.  
SPARKS, NV USA 89431-5902  
Ph. (775) 356-0606  
Fax. (775) 356-1413  
EMAIL: info@aallabs.com

**IPOP LLC**

*Frank Salmeron*  
*M. Harbeck*

*[Signature]*

COPIES TO : Edwin Epstein  
: CLIENT REFERENCE No: #1-#2  
: No. SAMPLES : 2  
: MAIN SAMPLE TYPE : ROCK

RECEIVED : 14-May-2018  
REPORTED : 18-May-2018

**COMPANY DISCLAIMER :-**

When small samples are submitted, AAL may process the sample at smaller than specified weights to retain  
When Values exceed upper limits, AAL will run an Over Range analysis, to establish an accurate value. Ac  
Due to USDA Soil Quarantine programs - all foreign and some domestic soil material must be decontaminat  
which will result in loss of Mercury (Hg).

ulp for quality control reassay.  
l cost will apply.  
ying @ 125c for 48 hours,

**NEVADA LEGISLATIVE DISCLAIMER :-**

The results of this assay were based solely upon the content of the sample submitted. Any decision to  
invest should be made only after the potential investment value of the claim or deposit has been determined  
based on the results of assays of multiple samples of geological materials collected by the prospective  
investor or by a qualified person selected by him and based on an evaluation of all engineering data  
which is available concerning any proposed project. Nevada State Law NRS 519.130.

ANALYSIS METHOD UNIT LOWER LIMIT	Wt Au-150	Wt 150 Au 150	Wt Au(1)	Au(2)	u Calc	Ag	Al	As	Au	Ba	Be	Bi	Ca	Cd	Ce	Co	Cr	Cs	Cu	Dy	Er	Eu	Fe
METHOD	BRPP2KG.30-ICP	PB30SF	PB30SF	PB30SF	PB30SF	PB30SF	PB30SF	PB30SF	PB30SF	-5A-UT	-5A-UT	-5A-UT	-5A-UT	-5A-UT	-5A-UT	-5A-UT	-5A-UT	-5A-UT	-5A-UT	-5A-UT	-5A-UT	-5A-UT	-5A-UT
UNIT	kg	ppm	grams	ppm	grams	ppm	gram	ppm	ppm	ppm	ppm	ppm	ppm	ppm	ppm	ppm	ppm	ppm	ppm	ppm	ppm	ppm	ppm
LOWER LIMIT	0.01	0.003	0.01	0.003	1	0.003	0.003	0.003	0.005	10	0.1	0.001	0.1	0.01	0.005	10	0.01	0.01	0.1	0.01	0.01	0.01	0.01

ANALYSIS METHOD UNIT LOWER LIMIT	Ga	Gd	Ge	Hf	Hg	Ho	In	K	La	Li	Lu	Mg	Mn	Mo	Na	Nb	Nd	Ni	P	Pb	Pr	Rb	Re	S	Sb	Sc
METHOD	ICP-5A-UT	-5A-UT	-5A-UT	-5A-UT	-5A-UT	-5A-UT	-5A-UT	-5A-UT	-5A-UT	-5A-UT	-5A-UT	-5A-UT	-5A-UT	-5A-UT	-5A-UT	-5A-UT	-5A-UT	-5A-UT	-5A-UT	-5A-UT	-5A-UT	-5A-UT	-5A-UT	-5A-UT	-5A-UT	-5A-UT
UNIT	ppm	ppm	ppm	ppm	ppm	ppm	ppm	ppm	ppm	ppm	ppm	ppm	ppm	ppm	ppm	ppm	ppm	ppm	ppm	ppm	ppm	ppm	ppm	ppm	ppm	ppm
LOWER LIMIT	0.02	0.01	0.01	0.01	0.005	0.01	0.01	10	0.1	0.2	0.01	10	0.2	0.02	10	0.005	0.01	0.1	10	1	0.01	0.02	0.005	10	0.02	0.01

ANALYSIS METHOD UNIT LOWER LIMIT	Se	Sm	Sn	Sr	Ta	Tb	Te	Th	Ti	Tl	Tm	U	V	W	Y	Yb	Zn	Zr	Al2O3	BaO	CaO	Cr2O3	Fe2O3	K2O	MgO	MnO	
METHOD	ICP-5A-UT	-5A-UT	-5A-UT	-5A-UT	-5A-UT	-5A-UT	-5A-UT	-5A-UT	-5A-UT	-5A-UT	-5A-UT	-5A-UT	-5A-UT	-5A-UT	-5A-UT	-5A-UT	-5A-UT	-5A-UT	XRF-WR	XRF-WR	XRF-WR	XRF-WR	XRF-WR	XRF-WR	XRF-WR	XRF-WR	XRF-WR
UNIT	ppm	ppm	ppm	ppm	ppm	ppm	ppm	ppm	ppm	ppm	ppm	ppm	ppm	ppm	ppm	ppm	ppm	ppm	pct	pct	pct	pct	pct	pct	pct	pct	
LOWER LIMIT	0.1	0.01	0.02	0.1	0.01	0.01	0.02	0.005	10	0.003	0.01	0.01	0.1	0.01	0.01	0.01	0.2	0.1	0.01	0.01	0.01	0.01	0.01	0.01	0.01	0.01	

ANALYSIS METHOD UNIT LOWER LIMIT	Na2O	P2O5	SiO2	SrO	TiO2	V2O5	LOI
METHOD	XRF-WR	XRF-WR	XRF-WR	XRF-WR	XRF-WR	XRF-WR	LOI
UNIT	pct	pct	pct	pct	pct	pct	pct
LOWER LIMIT	0.01	0.01	0.01	0.01	0.01	0.01	0.01

SIGNATORY

ANALYSIS

\_\_\_\_\_  
\_\_\_\_\_  
\_\_\_\_\_

SP0122408  
FINAL REPORT



AMERICAN ASSAY LABORATORIES  
1500 GLENDALE AVE.  
SPARKS, NV USA 89431-5902  
Ph.(775) 356-0606  
Fax.(775) 356-1413  
EMAIL: AALLABS@NVBELL.NET

	<u>Abbreviation</u>	<u>Definition</u>	
Preparation	DIP	Sample Destroyed in Preparation	
	DIS	Sample Destroyed in Shipment	
	ISS	Insufficient Sample Submitted	
	SDI	Sample Diesel Impregnate	
	SHI	Sample Hydraulic Impregnate	
	SNR	Sample Not Received	
Analysis	STD - ??	International Reference Material Standard	
	STD - AAL##	AAL generated standard material	
	BLANK	AAL Laboratory Silica Blank	
	DTF	Data to Follow	
	DL	Detection Limit of Method	
	< or -	Less Than Lower Detection Limit of Method	
	>	Greater than Upper Limit of Method	
	N/A	Not Analyzed	
	NR	Not Reported	
	(R) column	Laboratory repeat weigh, digestion, analysis from original pulp or reject resp	
	D or -D after Sample II	Client submitted duplicate rig split sample	
	-R after Sample II	Repeat analysis from original pulp reweigh, digestion and analysis	
	-X after Sample II	Repeat analysis from reject resp, preparation, weigh, digestion and analysis	
	ppb	Parts per Billion 0.001 ppm = 1 ppb	
	ppm	Parts per Million 1 ppm = 1 mg/Kg	
	OPT	Troy Ounces per Short Ton(2,000 lbs)(1 ppm= 0.02917 OPT)	
	Oz	Troy Ounce = 31.103 grams	
	%	Percent 1%=10,000 ppb	
	g	Grams 1g=0.001 kilogram	
	mg	Milligrams 1mg=0.001gram	
	Kg	Kilograms 1Kg=1000gram	
	lbs	Pounds 1lb=0.454kilogram	
	Method	FA-PB##	Fire Assay Lead Collection - ## sample weight in gram
GRAV		Gravimetric (Weighed) finish	
SF		Screen Fire Assay reporting a plus, 2 minus fractions and a head Ca	
+ ###		Plus Fraction (Retained on top of Mesh) ###Screen Siz	
- ###		Minus Fraction (Passed through Mesh) ###Screen Siz	
CN		Cyanide Extractor	
ORE GRADE		2g sample made to 1000ml volumetric for results > upper limit of method	
Ox-H2SO4 or -HCl		Dilute acid leach for oxide fraction in copper or molybdenum analysis	
QLA		Dilute 10%H2SO4/0.5%Fe2(SO4)3 30C leach for acid soluble copper	
QLT		Dilute 15%H2SO4 30C leach for acid soluble copper	
SAP		Dilute 5%H2SO4/0.5%Fe2(SO4)3 85C leach for acid soluble & chalcocite copper	
D#A		Digestion #=2,3 or 4 Acid: 2A=HCl/HNO3 3A=HCl/HNO3/HClO4 4A=HCl/HNO3/HF/HClC	
HCl		Hydrochloric Acid(37%/v) Boiling Point 109	
HF		Hydrofluoric Acid(48%/v) Boiling Point 108C Extreme Health Hazard	
HClO4		Perchloric Acid(69%/v) Boiling Point 203C Extreme Fire/Explosion Hazard	
HNO3		Nitric Acid(69%/v) Boiling Point 121	
H2SO4		Sulfuric Acid(98% w/v) Boiling Point 338	
ICP-xB or -x2		ICP-AES and/or ICP-MS analysis using x=2, 3 or 4 acid digester	
LiBO2-C		Lithium Metaborate fusion in Carbon crucible	
Na2O2-C		Sodium Peroxide fusion in Carbon crucible	
Na2O2-Zr		Sodium Peroxide fusion in Zirconium crucible	
Technique		AAS	Atomic Absorption Spectroscopy
		ICP-AES	Inductively Coupled Plasma Atomic Emission Spectroscopy
	ICP-MS	Inductively Coupled Plasma Mass Spectroscopy	
	RG	Research Grade (Low detection limit ICP-AES)	
	UT	Ultra Trace (ICP-AES+ICP-MS analyses)	
	XRF-ED or -WE	X-Ray Fluorescence (-ED = Energy Dispersive) (-WD = Wavelength Dispersive)	
	XRD	X-Ray Diffractor	
	ELTRA-I	Carbon & Sulfur infrared detection analyzer inductive heating	
	ELTRA-R	Carbon, Hydrogen & Sulfur infrared detection analyzer resistance furnace	
	LECO-I	Nitrogen & Oxygen infrared detection analyzer inductive heating	
	MW	Microwave Digestion (-PT is at 1500psig and 300C)	
	SG-WD or -HF	Specific Gravity-WD=Water Displacement -HP=Helium Pycnometer 1g/cm3=62.4lbs/ft3	

**SP0122408**

**FINAL REPORT**

CLIENT : IPOP LLC  
 PROJECT : Rivers of Gold  
 REFERENCE : #1-#2  
 REPORTED : 18-May-2018

SAMPLES	Wt	Au	+150 Wt	+150 Au	-150 Wt	-150 Au(1)	-150 Au(2)	Au Calc	Ag	Al	As	Au	Ba
	BRPP2KG 0.01 kg	FA-PB30-ICP 0.003 ppm	FA-PB30SF 0.01 grams	FA-PB30SF 0.003 ppm	FA-PB30SF 1 grams	FA-PB30SF 0.003 ppm	FA-PB30SF 0.003 gram	FA-PB30SF 0.003 ppm	ICP-5A-UT 0.005 ppm	ICP-5A-UT 10 ppm	ICP-5A-UT 0.1 ppm	ICP-5A-UT 0.001 ppm	ICP-5A-UT 0.1 ppm
#1	6.50	0.003	23.06	0.018	771	0.004	0.003	0.004	0.105	41550	4.4	-0.001	240.5
#2	6.20	0.003	24.06	-0.003	705	0.004	0.004	0.004	0.143	42589	6.5	-0.001	278.7
#2-X		0.003	39.39	0.005	783	-0.003	-0.003	-0.003	0.072	40387	8.2	-0.001	249.7
BLANK		-0.003							-0.005	2131	3.1	-0.001	9.5
STD - OxA131		0.065											
STD - CDN-ME-1205									26.663	60658	533.7	0.883	807.6
STD - AAL2010													
STD - OREAS 905									0.536	76466	30.6	0.404	>2000

**SP0122408**

**FINAL REPORT**

CLIENT : IPOP LLC  
 PROJECT : Rivers of Gold  
 REFERENCE : #1-#2  
 REPORTED : 18-May-2018

SAMPLES	Be	Bi	Ca	Cd	Ce	Co	Cr	Cs	Cu	Dy	Er	Eu	Fe
	ICP-5A-UT 0.01 ppm	ICP-5A-UT 0.005 ppm	ICP-5A-UT 10 ppm	ICP-5A-UT 0.01 ppm	ICP-5A-UT 0.01 ppm	ICP-5A-UT 0.1 ppm	ICP-5A-UT 0.01 ppm	ICP-5A-UT 0.01 ppm	ICP-5A-UT 0.1 ppm	ICP-5A-UT 0.01 ppm	ICP-5A-UT 0.01 ppm	ICP-5A-UT 0.01 ppm	ICP-5A-UT 10 ppm
#1	0.71	0.079	8921	0.02	20.54	13.7	57.97	0.24	20.9	2.59	2.26	0.84	36647
#2	0.80	0.069	9215	0.03	27.15	14.2	76.56	0.26	33.5	2.85	2.31	1.05	47494
#2-X	0.72	0.054	8943	-0.01	23.39	12.8	57.58	0.27	23.5	2.63	2.06	1.02	37985
BLANK	0.04	0.014	96	-0.01	8.76	0.1	2.70	0.02	1.1	0.35	0.35	0.24	330
STD - OxA131													
STD - CDN-ME-1205	0.87	9.167	28061	22.72	33.10	25.6	79.30	0.62	2232.7	3.18	1.96	0.87	64543
STD - AAL2010													
STD - OREAS 905	2.86	6.041	5935	0.30	95.93	16.0	20.25	6.36	1585.9	3.48	1.25	1.34	41754

**SP0122408**

**FINAL REPORT**

CLIENT : IPOPOP LLC  
 PROJECT : Rivers of Gold  
 REFERENCE : #1-#2  
 REPORTED : 18-May-2018

SAMPLES	Ga	Gd	Ge	Hf	Hg	Ho	In	K	La	Li	Lu	Mg	Mn
	ICP-5A-UT 0.02 ppm	ICP-5A-UT 0.01 ppm	ICP-5A-UT 0.01 ppm	ICP-5A-UT 0.01 ppm	ICP-5A-UT 0.005 ppm	ICP-5A-UT 0.01 ppm	ICP-5A-UT 0.01 ppm	ICP-5A-UT 10 ppm	ICP-5A-UT 0.1 ppm	ICP-5A-UT 0.2 ppm	ICP-5A-UT 0.01 ppm	ICP-5A-UT 10 ppm	ICP-5A-UT 0.2 ppm
#1	6.85	3.74	-0.01	0.54	0.023	0.27	-0.01	6377	13.4	18.7	0.07	8620	463.3
#2	6.84	4.58	-0.01	1.02	0.021	0.31	0.01	7434	14.3	21.7	0.09	8868	568.1
#2-X	6.30	3.91	-0.01	2.62	0.022	0.32	0.01	6493	13.5	18.5	0.09	8048	474.6
BLANK	1.54	0.20	-0.01	2.14	0.006	0.02	-0.01	1137	3.1	1.3	-0.01	110	1.7
STD - OxA131													
STD - CDN-ME-1205	11.56	5.67	0.02	1.91	0.773	0.47	1.48	12298	18.7	22.2	0.14	12767	839.1
STD - AAL2010													
STD - OREAS 905	25.65	6.89	0.02	7.24	0.038	0.44	0.53	29093	44.9	22.5	0.06	2803	386.7

**SP0122408**

**FINAL REPORT**

CLIENT : IPOPOP LLC  
 PROJECT : Rivers of Gold  
 REFERENCE : #1-#2  
 REPORTED : 18-May-2018

SAMPLES	Mo	Na	Nb	Nd	Ni	P	Pb	Pr	Rb	Re	S	Sb	Sc
	ICP-5A-UT 0.02 ppm	ICP-5A-UT 10 ppm	ICP-5A-UT 0.005 ppm	ICP-5A-UT 0.01 ppm	ICP-5A-UT 0.1 ppm	ICP-5A-UT 10 ppm	ICP-5A-UT 1 ppm	ICP-5A-UT 0.01 ppm	ICP-5A-UT 0.02 ppm	ICP-5A-UT 0.005 ppm	ICP-5A-UT 10 ppm	ICP-5A-UT 0.02 ppm	ICP-5A-UT 0.01 ppm
#1	2.17	15472	7.188	12.68	25.0	412	7	8.99	19.72	-0.005	2654	0.32	6.97
#2	3.53	15828	6.933	14.11	41.0	515	5	8.95	12.26	-0.005	4138	0.36	7.69
#2-X	2.40	15033	6.526	12.56	24.1	495	6	8.05	21.31	-0.005	3594	0.35	7.06
BLANK	0.27	99	-0.005	2.51	-0.1	-10	-1	2.70	1.35	-0.005	88	0.05	0.22
STD - OxA131													
STD - CDN-ME-1205	74.68	17699	15.647	16.51	172.7	719	1291	2.52	28.24	0.013	15153	23.87	11.16
STD - AAL2010													
STD - OREAS 905	3.50	22418	16.913	36.89	8.4	283	28	11.51	141.56	-0.005	698	1.11	4.81

**SP0122408**

**FINAL REPORT**

CLIENT : IPOPOP LLC  
 PROJECT : Rivers of Gold  
 REFERENCE : #1-#2  
 REPORTED : 18-May-2018

SAMPLES	Se	Sm	Sn	Sr	Ta	Tb	Te	Th	Ti	Tl	Tm	U	V
	ICP-5A-UT 0.1 ppm	ICP-5A-UT 0.01 ppm	ICP-5A-UT 0.02 ppm	ICP-5A-UT 0.1 ppm	ICP-5A-UT 0.01 ppm	ICP-5A-UT 0.01 ppm	ICP-5A-UT 0.02 ppm	ICP-5A-UT 0.005 ppm	ICP-5A-UT 10 ppm	ICP-5A-UT 0.003 ppm	ICP-5A-UT 0.01 ppm	ICP-5A-UT 0.01 ppm	ICP-5A-UT 0.1 ppm
#1	-0.1	3.40	1.29	109.1	0.90	3.12	-0.02	2.609	3938	0.056	0.06	0.48	54.4
#2	-0.1	3.01	2.31	114.1	1.24	3.07	-0.02	2.869	3908	0.068	0.08	0.56	54.3
#2-X	-0.1	3.38	1.97	106.7	1.18	3.14	-0.02	3.032	3818	0.072	0.08	0.60	51.6
BLANK	1.1	1.33	0.63	4.3	-0.01	-0.01	-0.02	0.297	121	0.005	-0.01	0.05	1.5
STD - OxA131													
STD - CDN-ME-1205	2.2	4.48	26.51	334.4	1.67	2.34	0.54	4.609	3197	1.808	0.11	1.19	83.0
STD - AAL2010													
STD - OREAS 905	1.4	6.75	4.10	163.2	1.84	0.60	0.07	13.204	1275	0.685	0.07	4.48	-0.1



**SP0122408**

**FINAL REPORT**

CLIENT : IPOP LLC  
 PROJECT : Rivers of Gold  
 REFERENCE : #1-#2  
 REPORTED : 18-May-2018

SAMPLES	W	Y	Yb	Zn	Zr	Al2O3	BaO	CaO	Cr2O3	Fe2O3	K2O	MgO	MnO	Na2O	P2O5	SiO2	SrO
	ICP-5A-UT 0.01 ppm	ICP-5A-UT 0.01 ppm	ICP-5A-UT 0.01 ppm	ICP-5A-UT 0.2 ppm	ICP-5A-UT 0.1 ppm	XRF-WR 0.01 pct	XRF-WR 0.01 pct	XRF-WR 0.01 pct	XRF-WR 0.01 pct	XRF-WR 0.01 pct	XRF-WR 0.01 pct	XRF-WR 0.01 pct	XRF-WR 0.01 pct	XRF-WR 0.01 pct	XRF-WR 0.01 pct	XRF-WR 0.01 pct	XRF-WR 0.01 pct
#1	0.74	12.89	1.22	49.5	24.0	7.44	0.04	1.38	0.01	5.25	0.72	1.41	0.06	1.79	0.08	77.04	0.02
#2	1.71	13.68	1.31	48.9	28.8	7.85	0.05	1.43	-0.01	6.69	0.86	1.48	0.07	1.78	0.09	74.00	0.01
#2-X	0.86	13.01	1.23	53.1	25.9	7.35	0.05	1.40	-0.01	5.45	0.75	1.34	0.08	1.70	0.09	75.19	0.01
BLANK	0.02	0.50	0.05	4.5	4.1	0.40	-0.01	0.03	-0.01	0.05	0.11	-0.01	-0.01	-0.01	-0.01	96.37	-0.01
STD - OxAl31																	
STD - CDN-ME-1205	19.70	13.35	1.33	3411.8	61.4												
STD - AAL2010						10.20	0.26	6.92	0.03	6.37	3.19	2.99	0.09	0.53	0.23	60.49	0.03
STD - OREAS 905	2.62	15.48	0.68	132.6	242.3												

**SP0122408**

**FINAL REPORT**

CLIENT : IPOP LLC  
PROJECT : Rivers of Gold  
REFERENCE : #1-#2  
REPORTED : 18-May-2018

	TiO2	V2O5	LOI
SAMPLES	XRF-WR	XRF-WR	LOI
	pct	pct	pct
#1	0.83	0.01	1.96
#2	0.87	0.02	2.03
#2-X	0.85	0.02	2.21
BLANK	0.04	-0.01	0.35
STD - OxA131			
STD - CDN-ME-1205			
STD - AAL2010	0.46	0.04	8.26
STD - OREAS 905			

EXHIBIT B

# Environmental Chain of Custody Form

### Additional Report Recipients

To	American Assay Labs	To	
Address	9811 West Charleston Blvd, Las Vegas	Address	

Client:	IPOP	Location Name:	Borehole 18-01
Profile:	Sediment Lithology	Collector:	Jeffrey Rezin
Location Code:	Claim 30, 31, 32 U	Event Desc:	Core Drilling

Notes:	Known Hazards
N/A	Flammable <input type="checkbox"/> Poison <input type="checkbox"/>
	Radiological <input type="checkbox"/> Other <input type="checkbox"/>

#	Sample ID, Description	Matrix	Collection		Sample Comments	Analyses				Total number of containers	Field Test Results						
			Actual Collection			Date	Time	Fluoride	pH		Specific Gravity	Total Solids	Total Dissolved Solids	Total Suspended Solids	Total Volatile Solids		
			Date	Time													
1	BH18-01 0-4	SD	4/13/19	1334													
2	BH18-01 4-10.5	SD	4/13/19														
3	BH18-01 10.5-14.5	SD	4/13/19														
4	BH18-01 14.5-18	SD	4/13/19														
5	BH18-01 18-22	SD	4/13/19														
6	BH18-01 22-26.5	SD	4/13/19														
7	BH18-01 26.5-31.5	SD	4/13/19	1623													
8																	

Transfers	Released By	Date/Time	Received By	Date/Time	Sample Condition				Receipt Temperature:
					Received on Ice		Samples Intact		
1	Jeffrey Rezin	4/20/19			Y	N	Y	N	
2		5:00 pm			Y	N	Y	N	
3	Yvette AAL	6/4 3:48 pm	Claudia Weiss	6/4/19 3:50 pm	Y	N	Y	N	

X 4 *[Signature]* 10:17 AM

# Environmental Chain of Custody Form

### Additional Report Recipients

To: American Assay Labs	To:
Address: 9811 W Charleston Blvd	Address:
#2-444 Las Vegas, NV	

Client: IPOP	Location Name: BH18-02	Notes:
Profile: Sediment Lithology	Collector: Jeffrey Rezin	
Location Code: C1win 30, 31, 32	Event Desc: Core Drilling	

Known Hazards		
Flammable	Poison	
Radiological	Other	

#	Sample ID, Description	Matrix	Collection		Sample Comments	Analyses					Total number of containers	Field Test Results				
			Actual Collection			Date	Time									
			Date	Time												
1	BH18-02 0-6	SD	4/17/19	1632												
2	BH18-02 6-10	SD	4/17/19													
3	BH18-02 10-14	SD	4/17/19													
4	BH18-02 14-17	SD	4/17/19													
5	BH18-02 17-20	SD	4/17/19													
6	BH18-02 20-23.5	SD	4/17/19	1900												
7																
8																

Transfers	Released By	Date/Time	Received By	Date/Time	Sample Condition				Receipt Temperature:
					Received on Ice		Samples Intact		
1	Jeffrey Rezin	4/20/19			Y	N	Y	N	
2		5:00pm			Y	N	Y	N	
3	Yvette AAL	6/4 3:48	Claudia Wise	6/4/19 3:50pm	Y	N	Y	N	

4 ~~Jeffrey Rezin~~ 10:12 AM 6/5

# Environmental Chain of Custody Form

### Additional Report Recipients

To	American Assay Labs	To	
Address	9811 West Charleston Blvd #2-444	Address	

Client: IPOP	Location Name: BH18-03	Notes: Las Vegas, NV	Known Hazards	
Profile: Sediment Lithology	Collector: Jeffrey Rezin		Flammable	Poison
Location Code: Claim 30, 31, 32	Event Desc: Core Drilling		Radiological	Other

#	Sample ID, Description	Matrix	Collection		Sample Comments	Analyses				Total number of containers	Field Test Results							
			Actual Collection			Date	Time											
			Date	Time														
1	BH18-03 0-4'	SD	4/14/19	1115														
2	BH18-03 4-10'	SD																
3	BH18-03 10-14'	SD																
4	BH18-03 14-19'	SD																
5	BH18-03 19-23'	SD																
6	BH18-03 23-26'	SD	↓	1342														
7																		
8																		

Transfers	Released By	Date/Time	Received By	Date/Time	Sample Condition				Receipt Temperature:
					Received on Ice		Samples Intact		
1	Jeffrey Rezin	4/20/19			Y	N	Y	N	
2		5:00pm			Y	N	Y	N	
3	Yvette AAL	6/4 3:48	Claudia Wise	6/4/19 3:50pm	Y	N	Y	N	

4 ~~Jeffrey Rezin~~ 6/5 10:13am

# Environmental Chain of Custody Form

Additional Report Recipients			
To	American Assaying Labs	To	
Address	9811 West Charleston Blvd #2-444	Address	
Notes: Las Vegas, NV			
Known Hazards			
Flammable	Poison	Radiological	Other

Client:	IPOP	Location Name:	BH18-04
Profile:	Sediment Lithology	Collector:	Jeffrey Rezin
Location Code:	CWMA 30, 31, 32	Event Desc:	Core Drilling

#	Sample ID, Description	Matrix	Collection		Sample Comments	Analyses				Total number of containers	Field Test Results						
			Actual Collection			Date	Time										
			Date	Time													
1	BH18-04 0-8.5	SD	4/14/19	1401													
2	BH18-04 8.5-12.5	SD	4/14/19														
3	BH18-04 12.5-17	SD	4/14/19														
4	BH18-04 17-20.5	SD	4/14/19														
5	BH18-04 20.5-23.5	SD	4/14/19	1722													
6																	
7																	
8																	

Transfers	Released By	Date/Time	Received By	Date/Time	Sample Condition				Receipt Temperature:
					Received on Ice	Samples Intact			
1	Jeffrey Rezin	4/20/19			Y	N	Y	N	
2		5:00pm			Y	N	Y	N	
3	Cherette AAL	6/4 3:48	Claudia Wise	6/4/19 3:50pm	Y	N	Y	N	

4 ~~Jeffrey Rezin~~ 6/5 10:12am

# Environmental Chain of Custody Form

Additional Report Recipients			
To	American Assing Lab	To	
Address	9811 W Charleston Blvd #2-444, Las Vegas, NV	Address	
Notes:			
		Known Hazards	
		Flammable	Poison
		Radiological	Other

Client:	IRSP	Location Name:	BH18-05
Profile:	Sediment Sampling	Collector:	Jeffrey Rezin
Location Code:	Claim 30, 31, 32	Event Desc:	Core Drilling

#	Matrix Codes: DW=Drinking Water W=Water WW=Waste Water SO=Soil SL=Solid SD=Sediment	Matrix	Collection		Sample Comments	Analyses				Total number of containers	Field Test Results						
			Actual Collection			Date	Time										
			Date	Time													
1	BH18-05 0-5.5'	SD	4/14/19	1744													
2	BH18-05 5.5-9.5'																
3	BH18-05 9.5-15.5'																
4	BH18-05 15.5-19.5'																
5	BH18-05 19.5-23.5'																
6	BH18-05 23.5-28'																
7	BH18-05 28-33.5'			2057													
8																	

Transfers	Released By	Date/Time	Received By	Date/Time	Sample Condition				Receipt Temperature:
					Received on Ice	Samples Intact			
1	Jeffrey Rezin	4/20/19			Y	N	Y	N	
2		5:00 pm			Y	N	Y	N	
3	Yvette AAL	6/4 3:49	Claudia Wise	6/4/19 3:50pm	Y	N	Y	N	

4 ~~Jeffrey Rezin~~ 6/5 10:12am



# Environmental Chain of Custody Form

Additional Report Recipients			
To	Americana Assay Labs	To	
Address	9811 W Charleston Blvd #2-444 Las Vegas, NV	Address	
Notes:			
		Known Hazards	
		Flammable	Poison
		Radiological	Other

Client:	IFOP	Location Name:	BH18-06
Profile:	Sediment hydrology	Collector:	Jeffrey Rezin
Location Code:	Claim 30, 31, 32	Event Desc:	Core Drilling

#	Matrix Codes: DW=Drinking Water W=Water WW=Waste Water SO=Soil SL=Solid SD=Sediment	Matrix	Collection		Sample Comments	Analyses								Total number of containers	Field Test Results			
			Actual Collection															
			Date	Time														
1	BH18-06 0-5.5'	SD	4/17/19	1337														
2	BH18-06 5.5-9.5'	SD																
3	BH18-06 9.5-13.5'	SD																
4	BH18-06 13.5-15.5'	SD																
5	BH18-06 15.5-21.5'	SD		1603														
6																		
7																		
8																		

Transfers	Released By	Date/Time	Received By	Date/Time	Sample Condition				Receipt Temperature:
					Received on Ice		Samples Intact		
1	Jeffrey Rezin	4/20/19			Y	N	Y	N	
2		5:00pm			Y	N	Y	N	
3			Claudia Wise	6/4/19 3:50pm	Y	N	Y	N	

4/20/19 6/5 10:17 4/5

# Environmental Chain of Custody Form

Additional Report Recipients			
To	American Assesing Labs	To	
Address	9811 W Charleston Blvd #2-444 Las Vegas, NV	Address	
Known Hazards			
Flammable		Poison	
Radiological		Other	

Client:	IPOP	Location Name:	BH18-07
Profile:	Sediment Lithology	Collector:	Jeffrey Rezin
Location Code:	Claim 30, 31, 32	Event Desc:	Core Drilling

Notes:	
--------	--

#	Sample ID, Description	Matrix	Collection		Sample Comments	Analyses				Total number of containers	Field Test Results							
			Actual Collection			Date	Time	1	2		3	4	1	2	3	4		
			Date	Time														
1	BH18-07 0-7'	SD	4/15/19	1032														
2	BH18-07 7-11'	SD																
3	BH18-07 11-15'	SD																
4	BH18-07 15-19'	SD																
5	BH18-07 19-22.5'	SD		1301														
6																		
7																		
8																		

Transfers	Released By	Date/Time	Received By	Date/Time	Sample Condition				Receipt Temperature:
					Received on Ice	Samples Intact			
1	Jeffrey Rezin	4/20/19			Y	N	Y	N	
2		5:00 pm			Y	N	Y	N	
3	Yvette AAL	6/4 3:49	Claudia Wise	6/4/19 3:50 pm	Y	N	Y	N	

4 ~~Jeffrey Rezin~~ 6/5 10:19 AM

# Environmental Chain of Custody Form

### Additional Report Recipients

To	American Assay Labs	To	
Address	9811 W Charleston Blvd #2-444 Las Vegas, NV	Address	
Known Hazards			
Flammable		Poison	
Radiological		Other	

Client:	IDOP	Location Name:	BH 18-08
Profile:	Sediment Lithology	Collector:	Jeffrey Rezin
Location Code:	Claim 30, 31, 32	Event Desc:	Core Drilling

Notes:	
--------	--

#	Sample ID, Description	Matrix	Collection		Sample Comments	Analyses				Total number of containers	Field Test Results							
			Actual Collection			Date	Time	1	2		3	4	1	2	3	4		
			Date	Time														
1	BH18-08 0-6'	SD	4/15	1331														
2	BH18-08 6-10'	SD																
3	BH18-08 10-14'	SD																
4	BH18-08 14-18'	SD																
5	BH18-08 18-21.5'	SD																
6	BH18-08 21.5-24.5'	SD		1559														
7																		
8																		

Transfers	Released By	Date/Time	Received By	Date/Time	Sample Condition				Receipt Temperature:
					Received on Ice		Samples Intact		
1	Jeffrey Rezin	4/20/19			Y	N	Y	N	
2		5:00 pm			Y	N	Y	N	
3	Yvette	6/4 3:49	Claudia Wise	6/4/19 3:50 pm	Y	N	Y	N	

4 ~~for~~ 6/5/19 10:18 am

# Environmental Chain of Custody Form

### Additional Report Recipients

To: American Assay Labs	To:
Address: 9811 W Charleston Blvd	Address:
#2-444 Las Vegas, NV	

Client: IPOP	Location Name: BH 18-09	Notes:	Known Hazards
Profile: Sediment Lithology	Collector: Jeffrey Rezin		Flammable <input type="checkbox"/> Poison <input type="checkbox"/>
Location Code: Claim 30, 31, 32	Event Desc: Core Drilling		Radiological <input type="checkbox"/> Other <input type="checkbox"/>

#	Sample ID, Description	Matrix	Collection		Sample Comments	Analyses				Total number of containers	Field Test Results							
			Actual Collection			Date	Time	1	2		3	4	5	6	7	8		
			Date	Time														
1	BH 18-09 0-6'	SD	4/17/19	1031														
2	BH 18-09 6-10'	SD																
3	BH 18-09 10-14'	SD																
4	BH 18-09 14-18.5'	SD																
5	BH 18-09 18.5-21.5'	SD																
6	BH 18-09 21.5-25.5'	SD	✓	1307														
7																		
8																		

Transfers	Released By	Date/Time	Received By	Date/Time	Sample Condition				Receipt Temperature:
					Received on Ice		Samples Intact		
1	Jeffrey Rezin	4/20/19			Y	N	Y	N	
2		5:00pm			Y	N	Y	N	
3	Yvette AAL	6/4 3:49	Claudia Wise	6/4/19 3:50pm	Y	N	Y	N	

4 ~~Jeffrey Rezin~~ 6/5 10:17

# Environmental Chain of Custody Form

Additional Report Recipients			
To	American Assay Labs	To	
Address	7815 W Charleston Blvd #2-444 Las Vegas, NV	Address	

Client:	IDDP	Location Name:	BH18-10
Profile:	Sediment Lithology	Collector:	Jeffrey Rezin
Location Code:	Claim 30, 31, 32	Event Desc:	Core Drilling

Notes:	Known Hazards
	Flammable <input type="checkbox"/> Poison <input type="checkbox"/>
	Radiological <input type="checkbox"/> Other <input type="checkbox"/>

#	Sample ID, Description	Matrix	Collection		Sample Comments	Analyses				Total number of containers	Field Test Results							
			Actual Collection			Date	Time	1	2		3	4	1	2	3	4		
			Date	Time														
1	BH18-10 0-4	SD	4/15/19	1630														
2	BH18-10 4-8	SD																
3	BH18-10 8-12	SD																
4	BH18-10 12-16	SD																
5	BH18-10 16-20	SD																
6	BH18-10 20-28	SD		1127														
7																		
8																		

Transfers	Released By	Date/Time	Received By	Date/Time	Sample Condition				Receipt Temperature:
					Received on Ice		Samples Intact		
1	Jeffrey Rezin	4/20/19			Y	N	Y	N	
2		5:00 PM			Y	N	Y	N	
3	<del>Jeffrey Rezin</del> AAL	6/4 3:41	Claudia Wise	6/4/19 3:50 pm	Y	N	Y	N	

4 ~~Jeffrey Rezin~~ 6/5 10:11 AM

# Environmental Chain of Custody Form

Additional Report Recipients			
To	American Assay Lab	To	
Address	9811 W Charleston Blvd #2-444 Las Vegas, NV	Address	
Known Hazards			
Flammable		Poison	
Radiological		Other	

Client:	TPOP	Location Name:	BH18-11
Profile:	Sediment Lithology	Collector:	Jeffrey Rezin
Location Code:	Clubs 30, 31, 32	Event Desc:	Core Drilling

Notes:	
--------	--

#	Sample ID, Description	Matrix	Collection		Sample Comments	Analyses				Total number of containers	Field Test Results								
			Actual Collection			Date	Time	1	2		3	4	1	2	3	4			
			Date	Time															
1	BH18-11 0-4	SD	4/16/19	0952															
2	BH18-11 4-8	SD	↓																
3	BH18-11 8-12	SD																	
4	BH18-11 12-16	SD																	
5	BH18-11 16-19	SD																	
6	BH18-11 19-22	SD																	
7	BH18-11 Slough	SD			1215														
8																			

Transfers	Released By	Date/Time	Received By	Date/Time	Sample Condition				Receipt Temperature:
					Received on Ice		Samples Intact		
1	Jeffrey Rezin	4/20/19			Y	N	Y	N	
2		5:00pm			Y	N	Y	N	
3	Yvette AAL	6/4 3:49	Claudia Wise	6/4/19 3:50pm	Y	N	Y	N	

*John M. [Signature]* 6/5/19 10:17am

*[Handwritten mark]*

# Environmental Chain of Custody Form

Additional Report Recipients			
To	American Assump Labs	To	
Address	9811 W Charleston Blvd #2-444 Las Vegas NV	Address	

Client: IFOP	Location Name: BH18-12	Notes:	
Profile: Sediment Lithology	Collector: Jeffrey Rezin		
Location Code: Claim 30, 31, 32	Event Desc: Core Drilling		

Known Hazards		
Flammable	Poison	
Radiological	Other	

#	Sample ID, Description	Matrix	Collection		Sample Comments	Analyses					Total number of containers	Field Test Results					
			Actual Collection														
			Date	Time													
1	BH18-12 0-5.5'	SD	4/16/20	1322													
2	BH18-12 5.5-8'	SD															
3	BH18-12 8-13.5'	SD															
4	BH18-12 13.5-15.5'	SD															
5	BH18-12 15.5-19.5'	SD															
6	BH18-12 19.5-24.5'	SD		1621													
7																	
8																	

Transfers	Released By	Date/Time	Received By	Date/Time	Sample Condition				Receipt Temperature:
					Received on Ice	N	Y	N	
1	Jeffrey Rezin	4/20/19			Y	N	Y	N	
2		5:00 pm			Y	N	Y	N	
3	Yvette AAL	6/4 3:49	Claudia Wise	6/4/19 3:50 pm	Y	N	Y	N	

4 ~~Jeffrey Rezin~~ 6/5 10:17

# Environmental Chain of Custody Form

### Additional Report Recipients

To	To
Address	Address

To: Amesstein Assaying Labs  
 Address: 9811 W Charleston Blvd  
#2-444 Las Vegas, NV

Client:	Location Name:	Notes:	
Profile:	Collector:		Known Hazards
Location Code:	Event Desc:		Flammable Poison Radiological Other

Client: IFOP      Location Name: BH18-13      Notes:   
 Profile: Sediment lithology      Collector: Jeffrey Rezin        
 Location Code: Claim 30, 31, 32      Event Desc: Core Drilling

#	Sample ID, Description	Matrix	Collection		Sample Comments	Analyses				Total number of containers	Field Test Results					
			Actual Collection			Date	Time									
			Date	Time												
1	BH18-13 0-5.5'	SD	4/16/19	1702												
2	BH18-13 5.5-9.5'	SD														
3	BH18-13 9.5-13.5'	SD														
4	BH18-13 13.5-17.5'	SD														
5	BH18-13 17.5-21.5'	SD		1900												
6																
7																
8																

Transfers	Released By	Date/Time	Received By	Date/Time	Sample Condition				Receipt Temperature:
					Received on Ice	Samples Intact			
1	Jeffrey Rezin	4/20/19			Y	N	Y	N	
2		5:00pm			Y	N	Y	N	
3	Yvette AAL	6/4/3:50	Claudia Wise	6/4/19 3:50pm	Y	N	Y	N	

4 ~~Jeffrey Rezin~~ 6/5 10:12am



**EXHIBIT : C**

**SP0126278  
FINAL REPORT**

Multi Element Package

AU  
XRD



AMERICAN ASSAY LABORATORIES  
1500 GLENDALE AVE.  
SPARKS, NV USA 89431-5902  
Ph. (775) 356-0606  
Fax. (775) 356-1413  
EMAIL: info@aallabs.com

**IPOP LLC**

*M. Epstein*  
*[Signature]*

COPIES TO : Edwin Epstein CLIENT REFERENCE No: BH18-01 to BH18-13 COM RECEIVED : 29-Apr-2019  
: No. SAMPLES : 13 REPORTED : 15-May-2019  
: MAIN SAMPLE TYPE : COMPOSITES

**COMPANY DISCLAIMER :-**

When small samples are submitted, AAL may process the sample at smaller than specified weights to retain some pulp for quality control reassay. When Values exceed upper limits, AAL will run an Over Range analysis, to establish an accurate value. Additional cost will apply. Due to USDA Soil Quarantine programs - all foreign and some domestic soil material must be decontaminated by drying @ 125c for 48 hours, which will result in loss of Mercury (Hg).

**NEVADA LEGISLATIVE DISCLAIMER :-**

The results of this assay were based solely upon the content of the sample submitted. Any decision to invest should be made only after the potential investment value of the claim or deposit has been determined based on the results of assays of multiple samples of geological materials collected by the prospective investor or by a qualified person selected by him and based on an evaluation of all engineering data which is available concerning any proposed project. Nevada State Law NRS 519.130.

ANALYSIS	Ag	Al	As	Ba	Be	Bi	Ca	Cd	Ce	Co	Cr	Cs	Cu	Fe	Ga	Ge	Hf	In	K	La	Li	Mg	Mn	Mo	Na	Nb
METHOD	ICP-5AM48	-5AM48	-5AM48	-5AM48	-5AM48	-5AM48	-5AM48	-5AM48	-5AM48	-5AM48	-5AM48	-5AM48	-5AM48	-5AM48	-5AM48	-5AM48	-5AM48	-5AM48	-5AM48	-5AM48	-5AM48	-5AM48	-5AM48	-5AM48	-5AM48	-5AM48
UNIT	ppm	ppm	ppm	ppm	ppm	ppm	ppm	ppm	ppm	ppm	ppm	ppm	ppm	ppm	ppm	ppm	ppm	ppm	ppm	ppm	ppm	ppm	ppm	ppm	ppm	ppm
LOWER LIMIT	0.05	100	0.1	5	0.01	0.01	100	0.02	0.1	0.1	0.1	0.1	0.1	100	0.02	0.01	0.01	0.01	100	0.01	0.2	100	5	0.1	100	0.02

ANALYSIS	Ni	P	Pb	Rb	Re	S	Sb	Sc	Se	Sn	Sr	Ta	Te	Th	Ti	Tl	U	V	W	Y	Zn	Zr	Al2O3	BaO	CaO	Cr2O3
METHOD	ICP-5AM48	-5AM48	-5AM48	-5AM48	-5AM48	-5AM48	-5AM48	-5AM48	-5AM48	-5AM48	-5AM48	-5AM48	-5AM48	-5AM48	-5AM48	-5AM48	-5AM48	-5AM48	-5AM48	-5AM48	-5AM48	-5AM48	FeOre	FeOre	FeOre	FeOre
UNIT	ppm	ppm	ppm	ppm	ppm	ppm	ppm	ppm	ppm	ppm	ppm	ppm	ppm	ppm	ppm	ppm	ppm	ppm	ppm	ppm	ppm	ppm	pct	pct	pct	pct
LOWER LIMIT	0.1	10	3	1	0.002	100	0.05	0.01	0.2	0.1	1	0.02	0.01	0.1	10	0.002	0.1	1	0.1	0.1	2	0.1	0.01	0.01	0.01	0.01

ANALYSIS	Fe2O3	K2O	MgO	MnO	Na2O	P2O5	SO3	SiO2	SrO	TiO2	V2O5	C	S	LOI	Quartz	ldspar	chlore	covite	alcite	hibole	Sand	Silt	Clay
METHOD XRF-FUSION	FeOre	FeOre	FeOre	FeOre	FeOre	FeOre	FeOre	FeOre	FeOre	FeOre	FeOre	TRA-CS	TRA-CS	LOI.nt	XRD.nt	XRD.nt	XRD.nt	XRD.nt	XRD.nt	XRD.nt	XRD.action	action	action
UNIT	pct	pct	pct	pct	pct	pct	pct	pct	pct	pct	pct	pct	pct	pct	pct	pct	pct	pct	pct	pct	PCT	PCT	PCT
LOWER LIMIT	0.01	0.01	0.01	0.01	0.01	0.01	0.01	0.01	0.01	0.01	0.01	0.003	0.003	0.01	1	1	1	1	1	1	0.01	0.01	0.01

SIGNATORY

ANALYSIS

\_\_\_\_\_  
\_\_\_\_\_  
\_\_\_\_\_

**SP0126278  
FINAL REPORT**



AMERICAN ASSAY LABORATORIES  
1500 GLENDALE AVE.  
SPARKS, NV USA 89431-5902  
Ph.(775) 356-0606  
Fax.(775) 356-1413  
EMAIL: AALLABS@NVBELL.NET

	<u>Abbreviation</u>	<u>Definition</u>	
Preparation	DIP	Sample Destroyed in Preparation	
	DIS	Sample Destroyed in Shipment	
	ISS	Insufficient Sample Submitted	
	SDI	Sample Diesel Impregnate	
	SHI	Sample Hydraulic Impregnate	
	SNR	Sample Not Received	
Analysis	STD - ??	International Reference Material Standard	
	STD - AAL##	AAL generated standard material	
	BLANK	AAL Laboratory Silica Blank	
	DTF	Data to Follow	
	DL	Detection Limit of Method	
	< or -	Less Than Lower Detection Limit of Method	
	>	Greater than Upper Limit of Method	
	N/A	Not Analyzed	
	NR	Not Reported	
	(R) column	Laboratory repeat weigh, digestion, analysis from original pulp or reject resp	
	D or -D after Sample II	Client submitted duplicate rig split sample	
	-R after Sample II	Repeat analysis from original pulp reweigh, digestion and analysis	
	-X after Sample II	Repeat analysis from reject resp, preparation, weigh, digestion and analysis	
	ppb	Parts per Billion 0.001 ppm = 1 ppb	
	ppm	Parts per Million 1 ppm = 1 mg/Kg	
	OPT	Troy Ounces per Short Ton(2,000 lbs)(1 ppm= 0.02917 OPT)	
	Oz	Troy Ounce = 31.103 grams	
	%	Percent 1%=10,000 ppb	
	g	Grams 1g=0.001 kilogram	
	mg	Milligrams 1mg=0.001gram	
	Kg	Kilograms 1Kg=1000gram	
	lbs	Pounds 1lb=0.454kilogram	
	Method	FA-PB##	Fire Assay Lead Collection - ## sample weight in gram
GRAV		Gravimetric (Weighed) finish	
SF		Screen Fire Assay reporting a plus, 2 minus fractions and a head Ca	
+ ###		Plus Fraction (Retained on top of Mesh) ###Screen Siz	
- ###		Minus Fraction (Passed through Mesh) ###Screen Siz	
CN		Cyanide Extractor	
ORE GRADE		2g sample made to 1000ml volumetric for results > upper limit of method	
Ox-H2SO4 or -HCl		Dilute acid leach for oxide fraction in copper or molybdenum analysis	
QLA		Dilute 10%H2SO4/0.5%Fe2(SO4)3 30C leach for acid soluble copper	
QLT		Dilute 15%H2SO4 30C leach for acid soluble copper	
SAP		Dilute 5%H2SO4/0.5%Fe2(SO4)3 85C leach for acid soluble & chalcocite copper	
D#A		Digestion #=2,3 or 4 Acid: 2A=HCl/HNO3 3A=HCl/HNO3/HClO4 4A=HCl/HNO3/HF/HClC	
HCl		Hydrochloric Acid(37%w/v) Boiling Point 109	
HF		Hydrofluoric Acid(48%w/v) Boiling Point 108C Extreme Health Hazard	
HClO4		Perchloric Acid(69%w/v) Boiling Point 203C Extreme Fire/Explosion Hazard	
HNO3		Nitric Acid(69%w/v) Boiling Point 121	
H2SO4		Sulfuric Acid(98% w/v) Boiling Point 338	
ICP-xB or -x2		ICP-AES and/or ICP-MS analysis using x=2, 3 or 4 acid digestior	
LiBO2-C		Lithium Metaborate fusion in Carbon crucible	
Na2O2-C		Sodium Peroxide fusion in Carbon crucible	
Na2O2-Zr		Sodium Peroxide fusion in Zirconium crucible	
Technique		AAS	Atomic Absorption Spectroscopy
		ICP-AES	Inductively Coupled Plasma Atomic Emission Spectroscopy
	ICP-MS	Inductively Coupled Plasma Mass Spectroscopy	
	RG	Research Grade (Low detection limit ICP-AES)	
	UT	Ultra Trace (ICP-AES+ICP-MS analyses)	
	XRF-ED or -WE	X-Ray Fluorescence (-ED = Energy Dispersive) (-WD = Wavelength Dispersive)	
	XRD	X-Ray Diffractor	
	ELTRA-I	Carbon & Sulfur infrared detection analyzer inductive heating	
	ELTRA-R	Carbon, Hydrogen & Sulfur infrared detection analyzer resistance furnace	
	LECO-I	Nitrogen & Oxygen infrared detection analyzer inductive heating	
	MW	Microwave Digestion (-PT is at 1500psig and 300C)	
	SG-WD or -HF	Specific Gravity-WD=Water Displacement -HP=Helium Pycnometer 1g/cm3=62.4lbs/ft	

**SP0126278**

**FINAL REPORT**

CLIENT : IPOP LLC  
 PROJECT : Bonanza Channel coring  
 REFERENCE : BH18-01 to BH18-13 COMP  
 REPORTED : 15-May-2019

SAMPLES	Ag	Al	As	Ba	Be	Bi	Ca	Cd	Ce	Co	Cr	Cs	Cu
	ICP-5AM48 0.05 ppm	ICP-5AM48 100 ppm	ICP-5AM48 0.1 ppm	ICP-5AM48 5 ppm	ICP-5AM48 0.01 ppm	ICP-5AM48 0.01 ppm	ICP-5AM48 100 ppm	ICP-5AM48 0.02 ppm	ICP-5AM48 0.1 ppm	ICP-5AM48 0.1 ppm	ICP-5AM48 0.1 ppm	ICP-5AM48 0.1 ppm	ICP-5AM48 0.1 ppm
BH18-01 COMP	0.06	45757	7.5	319	0.83	0.10	33599	-0.02	32.4	13.0	579.7	2.2	17.0
BH18-02 COMP	-0.05	35651	5.4	188	0.64	0.05	33464	-0.02	22.9	10.5	623.8	1.2	10.8
BH18-03 COMP	-0.05	40359	7.9	264	0.68	0.05	35281	-0.02	28.5	12.1	696.7	1.6	13.0
BH18-04 COMP	-0.05	47219	9.7	329	0.86	0.06	26952	-0.02	32.8	15.1	847.5	2.3	18.0
BH18-05 COMP	0.07	52408	9.4	308	0.93	0.09	27100	0.05	38.5	18.2	647.3	2.5	23.0
BH18-06 COMP	0.06	44364	7.1	272	0.76	0.05	26361	-0.02	28.8	13.5	505.1	1.9	13.2
BH18-06 COMP-X	-0.05	43080	7.5	267	0.77	0.05	26049	-0.02	29.7	13.3	489.8	1.9	13.1
BH18-07 COMP	-0.05	43335	8.3	257	1.01	0.06	24457	-0.02	29.6	12.5	543.2	1.9	13.6
BH18-08 COMP	-0.05	43575	9.7	285	0.74	0.05	11852	-0.02	30.1	13.5	1107.4	1.9	15.7
BH18-09 COMP	-0.05	51037	5.6	285	0.86	0.07	21816	0.06	36.8	19.5	480.5	2.2	20.9
BLANK	0.06	1938	-0.1	6	0.03	-0.01	-100	-0.02	9.7	0.2	2.9	0.1	0.8
BH18-10 COMP	0.05	52634	9.5	329	0.93	0.07	23188	0.05	37.3	18.6	748.7	2.4	23.2
BH18-11 COMP	0.06	45937	13.0	263	0.77	0.04	13475	-0.02	31.1	15.3	669.6	1.8	14.6
BH18-12 COMP	-0.05	55085	6.1	322	0.98	0.07	17251	0.07	40.0	18.4	553.1	2.4	23.3
BH18-12 COMP-X	-0.05	54041	6.1	320	0.96	0.08	16903	0.02	38.5	18.6	541.0	2.5	22.5
BH18-13 COMP	0.09	43401	4.5	253	0.71	0.04	27168	-0.02	29.6	14.1	431.1	1.5	13.4
STD - OREAS906													
STD - KZK-1													
STD - CDN-ME-1205	26.90	60010	1338.1	781	0.74	9.65	28495	18.31	33.9	22.7	72.0	1.8	2228.5
STD - AAL2010	97.68	53658	1045.1	1856	1.37	665.39	46584	3.31	50.7	25.3	149.1	29.4	2157.6
STD - OREAS905	0.52	73476	32.7	2636	2.52	5.25	6072	0.06	92.0	15.0	19.8	7.1	1542.7

**SP0126278**

**FINAL REPORT**

CLIENT : IPOPOP LLC  
 PROJECT : Bonanza Channel co  
 REFERENCE : BH18-01 to BH18-13  
 REPORTED : 15-May-2019

SAMPLES	Fe	Ga	Ge	Hf	In	K	La	Li	Mg	Mn	Mo	Na	Nb
	ICP-5AM48 100 ppm	ICP-5AM48 0.02 ppm	ICP-5AM48 0.01 ppm	ICP-5AM48 0.01 ppm	ICP-5AM48 0.01 ppm	ICP-5AM48 100 ppm	ICP-5AM48 0.01 ppm	ICP-5AM48 0.2 ppm	ICP-5AM48 100 ppm	ICP-5AM48 5 ppm	ICP-5AM48 0.1 ppm	ICP-5AM48 100 ppm	ICP-5AM48 0.02 ppm
BH18-01 COMP	31343	10.34	0.04	0.55	0.05	9957	16.60	22.9	10767	505	2.2	13847	7.07
BH18-02 COMP	25231	7.44	0.03	0.32	0.03	6170	11.95	14.8	7604	465	2.0	12790	5.72
BH18-03 COMP	29760	8.59	0.04	0.42	0.03	7714	14.60	17.8	8870	549	2.0	12935	6.96
BH18-04 COMP	34711	10.71	0.03	0.59	0.04	10408	16.60	24.8	11694	523	2.8	14313	7.78
BH18-05 COMP	40865	12.69	0.05	0.54	0.06	10988	19.22	26.6	13334	641	2.0	13803	8.72
BH18-06 COMP	30513	9.97	0.04	0.43	0.04	8527	14.74	21.5	10547	510	1.9	13574	6.80
BH18-06 COMP-X	29411	9.72	0.04	0.44	0.04	8336	15.02	20.9	10361	500	2.0	13367	6.64
BH18-07 COMP	29377	9.71	0.03	0.49	0.04	8726	15.35	20.1	10321	486	2.0	14367	6.67
BH18-08 COMP	33180	9.55	0.04	0.61	0.04	8258	15.11	20.0	9304	436	3.0	15704	7.31
BH18-09 COMP	40884	12.29	0.04	0.48	0.05	9761	18.52	25.5	13420	644	1.7	14477	8.48
BLANK	525	0.44	-0.01	0.07	-0.01	782	3.17	0.7	-100	-5	0.5	151	0.20
BH18-10 COMP	41377	12.38	0.04	0.51	0.05	10635	18.79	27.4	13557	595	2.5	13345	7.61
BH18-11 COMP	33033	9.89	0.03	0.54	0.04	8712	15.85	21.6	10204	476	2.1	16403	7.35
BH18-12 COMP	39530	11.91	0.04	0.50	0.05	11465	19.75	28.5	13929	581	1.9	15335	6.92
BH18-12 COMP-X	40235	12.24	0.03	0.52	0.05	11147	19.20	27.4	13723	573	2.0	14837	7.26
BH18-13 COMP	30336	9.27	0.04	0.40	0.04	7417	14.67	19.2	10067	523	1.6	12273	6.54
STD - OREAS906													
STD - KZK-1													
STD - CDN-ME-1205	64528	14.33	0.05	1.34	1.81	12177	17.49	20.8	13240	821	80.3	17630	14.60
STD - AAL2010	43150	14.56	0.11	1.90	0.86	22968	28.80	33.5	17893	649	463.9	4893	11.55
STD - OREAS905	41619	24.53	0.08	6.81	0.70	29352	43.56	20.9	2932	384	3.7	23238	17.78

**SP0126278**

**FINAL REPORT**

CLIENT : IPOPOP LLC  
 PROJECT : Bonanza Channel co  
 REFERENCE : BH18-01 to BH18-13  
 REPORTED : 15-May-2019

SAMPLES	Ni	P	Pb	Rb	Re	S	Sb	Sc	Se	Sn	Sr	Ta	Te
	ICP-5AM48 0.1 ppm	ICP-5AM48 10 ppm	ICP-5AM48 3 ppm	ICP-5AM48 1 ppm	ICP-5AM48 0.002 ppm	ICP-5AM48 100 ppm	ICP-5AM48 0.05 ppm	ICP-5AM48 0.01 ppm	ICP-5AM48 0.2 ppm	ICP-5AM48 0.1 ppm	ICP-5AM48 1 ppm	ICP-5AM48 0.02 ppm	ICP-5AM48 0.01 ppm
BH18-01 COMP	31.6	606	111	49	0.002	2487	0.89	8.87	-0.2	1.7	203	-0.02	-0.01
BH18-02 COMP	27.2	481	75	32	-0.002	688	0.78	6.62	-0.2	1.1	203	-0.02	-0.01
BH18-03 COMP	30.6	557	39	37	-0.002	1478	0.72	7.78	-0.2	1.3	212	-0.02	-0.01
BH18-04 COMP	39.2	641	45	50	-0.002	2868	0.96	9.08	-0.2	1.5	192	-0.02	0.01
BH18-05 COMP	42.0	732	21	54	-0.002	1031	0.87	11.22	-0.2	1.7	211	-0.02	0.03
BH18-06 COMP	33.2	574	61	43	-0.002	1372	0.81	8.51	-0.2	1.4	186	-0.02	-0.01
BH18-06 COMP-X	32.7	550	60	41	-0.002	1356	0.82	8.40	-0.2	1.3	180	-0.02	0.01
BH18-07 COMP	32.8	578	16	44	-0.002	1865	0.72	8.19	-0.2	1.4	166	-0.02	-0.01
BH18-08 COMP	38.6	602	25	39	0.002	3514	0.86	8.12	-0.2	1.4	129	-0.02	-0.01
BH18-09 COMP	40.9	762	23	47	0.002	932	0.85	12.15	-0.2	1.7	189	0.06	0.01
BLANK	0.4	18	-3	2	-0.002	-100	0.18	0.30	-0.2	-0.1	4	-0.02	-0.01
BH18-10 COMP	47.9	727	20	52	-0.002	1238	0.94	11.06	0.3	1.6	194	-0.02	0.01
BH18-11 COMP	35.9	618	18	39	-0.002	2874	0.77	9.08	-0.2	1.4	139	-0.02	-0.01
BH18-12 COMP	47.2	764	17	50	-0.002	1061	0.82	11.87	-0.2	1.6	163	-0.02	-0.01
BH18-12 COMP-X	46.6	747	17	53	-0.002	1036	0.84	11.62	-0.2	1.7	158	-0.02	0.02
BH18-13 COMP	29.9	616	13	34	-0.002	520	0.74	8.63	-0.2	1.2	193	0.13	-0.01
STD - OREAS906													
STD - KZK-1													
STD - CDN-ME-1205	191.3	781	1314	43	0.042	16009	23.89	10.79	3.7	14.8	348	0.54	0.57
STD - AAL2010	173.8	1243	1882	135	0.163	15576	53.09	7.97	15.6	26.2	223	1.22	7.22
STD - OREAS905	10.3	311	32	148	-0.002	726	2.10	4.52	2.4	4.1	162	4.03	0.07

**SP0126278**

**FINAL REPORT**

CLIENT : IPOPOP LLC  
 PROJECT : Bonanza Channel co  
 REFERENCE : BH18-01 to BH18-13  
 REPORTED : 15-May-2019

SAMPLES	Th	Ti	Tl	U	V	W	Y	Zn	Zr	Al2O3	BaO	
	ICP-5AM48	ICP-5AM48	ICP-5AM48	ICP-5AM48	ICP-5AM48	ICP-5AM48	ICP-5AM48	ICP-5AM48	ICP-5AM48	XRF-FUSION	XRF-FUSION	
	0.1 ppm	10 ppm	0.002 ppm	0.1 ppm	1 ppm	0.1 ppm	0.1 ppm	2 ppm	0.1 ppm	0.01 pct	0.01 pct	
BH18-01 COMP	4.6	3140	0.293	1.2	73	0.7	14.2	46	26.3		8.31	0.03
BH18-02 COMP	3.3	2863	0.202	0.8	56	0.7	11.8	33	19.7		6.42	0.02
BH18-03 COMP	3.8	3264	0.229	1.0	66	0.6	14.0	37	21.2		7.24	-0.01
BH18-04 COMP	4.6	3650	0.298	1.2	81	0.6	14.8	52	30.3		8.61	0.02
BH18-05 COMP	5.3	4156	0.298	1.3	93	0.8	17.9	56	30.0		9.72	0.04
BH18-06 COMP	4.2	3221	0.247	1.1	75	0.5	13.8	47	22.7		7.91	0.02
BH18-06 COMP-X	4.1	3128	0.249	1.1	75	0.5	13.6	46	23.0		8.03	0.01
BH18-07 COMP	4.5	3193	0.255	1.2	70	0.8	13.4	44	21.9		7.88	0.04
BH18-08 COMP	4.1	3375	0.251	1.2	71	0.6	13.8	45	26.9		8.09	0.03
BH18-09 COMP	5.0	4852	0.257	1.2	105	0.6	18.2	60	24.2		9.56	0.03
BLANK	0.9	109	0.015	0.2	2	-0.1	0.4	-2	3.1		0.26	-0.01
BH18-10 COMP	5.3	3914	0.283	1.5	99	0.6	17.0	58	26.9		9.80	0.03
BH18-11 COMP	4.1	3832	0.244	1.0	82	0.5	15.0	49	25.6		8.40	0.02
BH18-12 COMP	5.2	3964	0.286	1.3	100	0.6	18.1	62	29.0		10.06	0.04
BH18-12 COMP-X	5.3	4014	0.299	1.3	98	0.6	18.0	62	29.1		10.31	0.04
BH18-13 COMP	3.8	3571	0.199	1.0	75	0.5	14.4	44	21.9		7.78	-0.01
STD - OREAS906											14.18	0.27
STD - KZK-1												
STD - CDN-ME-1205	3.9	2961	1.921	1.4	98	14.7	12.1	3433	58.0			
STD - AAL2010	9.7	2221	4.314	10.9	154	51.5	16.7	407	52.8			
STD - OREAS905	14.9	1207	0.777	5.0	9	2.9	13.8	131	230.1			

**SP0126278**

**FINAL REPORT**

CLIENT : IPOP LLC  
 PROJECT : Bonanza Channel co  
 REFERENCE : BH18-01 to BH18-13  
 REPORTED : 15-May-2019

SAMPLES	CaO		Cr2O3		Fe2O3		K2O		MgO		MnO		Na2O		P2O5	
	XRF-FUSION	FeOre	XRF-FUSION	FeOre	XRF-FUSION	FeOre	XRF-FUSION	FeOre	XRF-FUSION	FeOre	XRF-FUSION	FeOre	XRF-FUSION	FeOre	XRF-FUSION	FeOre
	0.01		0.01		0.01		0.01		0.01		0.01		0.01		0.01	
	pct		pct		pct		pct		pct		pct		pct		pct	
BH18-01 COMP		4.52		0.10		4.25		1.05		1.72		0.09		1.62		0.10
BH18-02 COMP		4.46		0.10		3.38		0.65		1.19		0.08		1.55		0.08
BH18-03 COMP		4.67		0.11		3.97		0.81		1.39		0.09		1.58		0.09
BH18-04 COMP		3.60		0.13		4.76		1.09		1.86		0.08		1.73		0.11
BH18-05 COMP		3.68		0.10		5.54		1.15		2.15		0.10		1.68		0.13
BH18-06 COMP		3.72		0.08		4.13		0.89		1.74		0.09		1.63		0.10
BH18-06 COMP-X		3.57		0.08		4.17		0.91		1.66		0.09		1.65		0.09
BH18-07 COMP		3.29		0.09		4.06		0.91		1.62		0.08		1.71		0.10
BH18-08 COMP		1.61		0.18		4.53		0.86		1.48		0.08		1.86		0.10
BH18-09 COMP		2.97		0.07		5.61		1.03		2.13		0.10		1.70		0.13
BLANK		-0.01		-0.01		0.10		0.09		-0.01		0.02		-0.01		-0.01
BH18-10 COMP		3.16		0.12		5.66		1.13		2.18		0.09		1.68		0.13
BH18-11 COMP		1.83		0.11		4.50		0.90		1.63		0.08		1.90		0.10
BH18-12 COMP		2.31		0.08		5.53		1.20		2.20		0.08		1.84		0.13
BH18-12 COMP-X		2.34		0.08		5.56		1.21		2.19		0.09		1.78		0.13
BH18-13 COMP		3.66		0.06		4.17		0.77		1.57		0.08		1.56		0.10
STD - OREAS906		0.81		-0.01		7.96		3.36		0.42		0.07		3.00		0.05
STD - KZK-1																
STD - CDN-ME-1205																
STD - AAL2010																
STD - OREAS905																



**SP0126278**

**FINAL REPORT**

CLIENT : IPOPOP LLC  
 PROJECT : Bonanza Channel co  
 REFERENCE : BH18-01 to BH18-13  
 REPORTED : 15-May-2019

SAMPLES	SO3		SiO2		SrO		TiO2		V2O5		C		S		LOI	Quartz	Feldspar
	XRF-FUSION	FeOre	XRF-FUSION	FeOre	XRF-FUSION	FeOre	XRF-FUSION	FeOre	XRF-FUSION	FeOre	ELTRA-CS	ELTRA-CS	LOI	Quant	XRD	Quant	XRD
	0.01		0.01		0.01		0.01		0.01		0.003	0.003	0.01	1	1		
	pct		pct		pct		pct		pct		pct	pct	pct	pct	pct		
BH18-01 COMP		0.49		71.86		0.02		0.70		0.02	1.356	0.193	5.78		37		29
BH18-02 COMP		0.10		78.08		0.02		0.61		-0.01	0.951	0.053	4.09		45		17
BH18-03 COMP		0.26		74.11		0.02		0.71		-0.01	1.121	0.116	4.67		37		20
BH18-04 COMP		0.58		73.02		0.02		0.77		0.01	0.993	0.219	4.63		48		21
BH18-05 COMP		0.18		70.58		0.02		0.94		0.02	0.768	0.080	4.21		46		14
BH18-06 COMP		0.24		75.11		0.02		0.73		0.01	0.836	0.104	3.96		46		22
BH18-06 COMP-X		0.23		76.28		0.02		0.71		0.01	0.844	0.106	3.94		45		26
BH18-07 COMP		0.35		75.49		0.02		0.69		0.02	0.841	0.145	3.76		52		26
BH18-08 COMP		0.73		77.59		0.02		0.73		0.02	0.692	.267	2.91		47		25
BH18-09 COMP		0.15		72.64		0.02		1.01		0.02	0.429	0.075	3.08		47		24
BLANK		-0.01		99.41		-0.01		0.03		-0.01	0.007	0.008	0.25		100		
BH18-10 COMP		0.21		71.18		0.02		0.90		0.03	0.733	0.097	4.17		43		18
BH18-11 COMP		0.58		77.34		0.01		0.82		0.02	0.535	0.221	3.11		52		25
BH18-12 COMP		0.17		72.14		0.02		0.90		0.02	0.470	0.080	3.47		38		28
BH18-12 COMP-X		0.17		72.73		0.02		0.90		0.02	0.473	0.079	3.46		42		13
BH18-13 COMP		0.06		76.04		0.02		0.75		0.02	0.810	0.039	3.80		44		20
STD - OREAS906		0.04		66.41		0.02		0.18		-0.01			2.58				
STD - KZK-1											0.998	0.793					
STD - CDN-ME-1205																	
STD - AAL2010																	
STD - OREAS905																	

**SP0126278**

**FINAL REPORT**

CLIENT : IPOP LLC  
 PROJECT : Bonanza Channel co  
 REFERENCE : BH18-01 to BH18-13  
 REPORTED : 15-May-2019

SAMPLES	Clinocllore		Muscovite		Calcite		Amphibole		Sand		Silt		Clay	
	Quant	XRD	Quant	XRD	Quant	XRD	Quant	XRD	Size	Extraction	Size	Extraction	Size	Extraction
	1	1	1	1	1	1	1	1	0.01	0.01	0.01	0.01	0.01	0.01
	pct	pct	pct	pct	pct	pct	pct	pct	PCT	PCT	PCT	PCT	PCT	PCT
BH18-01 COMP		6		23		1		3		82.03		12.75		5.22
BH18-02 COMP		4		30		1		2		94.58		3.05		2.37
BH18-03 COMP		5		35		1		1		89.25		6.09		4.66
BH18-04 COMP		8		20		1		2		77.70		16.55		5.75
BH18-05 COMP		10		26		1		3		72.14		21.32		6.54
BH18-06 COMP		6		23		1		1		83.75		11.42		4.82
BH18-06 COMP-X		5		22		1		2		85.77		9.54		4.69
BH18-07 COMP		8		12		2		3		83.26		11.13		5.61
BH18-08 COMP		7		11		2		8		81.37		13.66		4.97
BH18-09 COMP		9		16				4		80.42		14.46		5.11
BLANK										6.09		84.27		9.65
BH18-10 COMP		12		23		1		3		77.63		18.01		4.36
BH18-11 COMP		8		13				2		82.24		14.12		3.64
BH18-12 COMP		7		25				2		72.33		22.06		5.60
BH18-12 COMP-X		7		36				2		74.59		17.70		7.71
BH18-13 COMP		6		28		1		2		84.32		12.14		3.55
STD - OREAS906														
STD - KZK-1														
STD - CDN-ME-1205														
STD - AAL2010														
STD - OREAS905														

**EXHIBIT : D**

DATE: 6.03.19 1506/Warehouse/Prep/Client

COMPANY: IPOP LLC (BOVANZA)

PICK-UP BY: Claudia Wise DATE: 6/4/19 3:50pm

SHIPPED VIA: \_\_\_\_\_ DATE: \_\_\_\_\_

DELIVERED BY: X Claudia Wise DATE: 6/5/19 10:18 AM

EMPLOYEE SIGNATURE: ~~[Signature]~~ 6/5/19 10:18 AM

**PULPS, SPLIT PULPS,  
CORE REJECTS, REJECTS  
COMPOSITIES, DISPOSAL**

**JOB NUMBERS:**

\*\*\*\*\*

SEE ATTACHED

126278

CLIENT: X Claudia Wise DATE: 6-4-19

AAL: [Signature] DATE: 6.03.19

DATE: 6.3.19 1506/Warehouse/Prep/Client

COMPANY: I POP LLC (BONANZA)

PICK-UP BY: Claudia Wise DATE: 6/4/19 3:50pm

SHIPPED VIA: \_\_\_\_\_ DATE: \_\_\_\_\_

DELIVERED BY: Claudia Wise DATE: 6/5/19 10:18am

EMPLOYEE SIGNATURE: [Signature] 6/5/19 10:18am

**PULPS, SPLIT PULPS,  
CORE REJECTS, REJECTS  
COMPOSITIES, DISPOSAL**

**JOB NUMBERS:**

\*\*\*\*\*

SEE ATTACHED

CLIENT: [Signature] DATE: 6-4-19

AAL: [Signature] DATE: 6.3.19

SP0126279,IPOP LLC,Bonanza Channel coring,BH18 COMP,BH18-COMP +50 ( 1 ),BH18-COMP -230 ( 4 ),4/29/2019,1 of 1,,05/01/19

SP0126278,IPOP LLC,Bonanza Channel coring,BH18-01 to BH18-13 COMP,BH18-01 COMP ( 1 ),BH18-13 COMP ( 13 ),4/29/2019,1 of 1,,05/03/19

SP0126277,IPOP LLC,Bonanza Channel coring,BH18-01 0-4' to BH18-13 17.5-21.5',BH18-01 0-4 ( 1 ),BH18-13 0-5.5 ( 73 ),4/29/2019,1 of 1,,05/02/19

**EXHIBIT : E**



# Chain of Custody Proof Sparks Nevada, AALabs.

BOXES ARE SEALED AND OPENED BY ORO INDUSTRIES







CORES ARRIVE



CLAUDIA WISE

Chain of Custody Proof  
Oro Industries Arrival, Paul Clift Signs

BOXES ARE SEALED AND OPENED BY ORO INDUSTRIES



DAVID, JOE GREENE AND CLAUDIA



JOE CLAUDIA WITH PAUL CLIFT  
CHAIN OF CUSTODY PAPERS



**PAUL CLIFT TAKING CUSTODY**



**PAUL SIGNING FOR SAMPLES DAVID AND CLAUDIA OBSERVE**



**READY TO UNLOAD OVER 300 LBS. OF CORES**



**UNLOAD SAMPLES START AT ORO INDUSTRIES**

**EXHIBIT : F**

**GETTING READY TO OPEN SEALED BOXES CORES**



**DAVID MAKING NOTATIONS ON SAMPLES ANALYSIS CONTROL SHEET**



**PROCESSING STARTS WITH LARGE CENTRIFUGE**



**NOTE SMALL SIZE MATERIAL**

DAVID WATCHES PAUL START EXTRACTION OF GOLD



DAVID HANDS ON EXAMINATION



AN EXCITED PAUL PANS FOR GOLD IMMEDIATELY



PAUL HAND PANNING MATERIAL 1



PAUL TESTS TURBIDITY OF MATERIAL STARTING HERE-PART 1 OF 2

PAUL JUST "SUPER SHOOK" THE MATERIAL

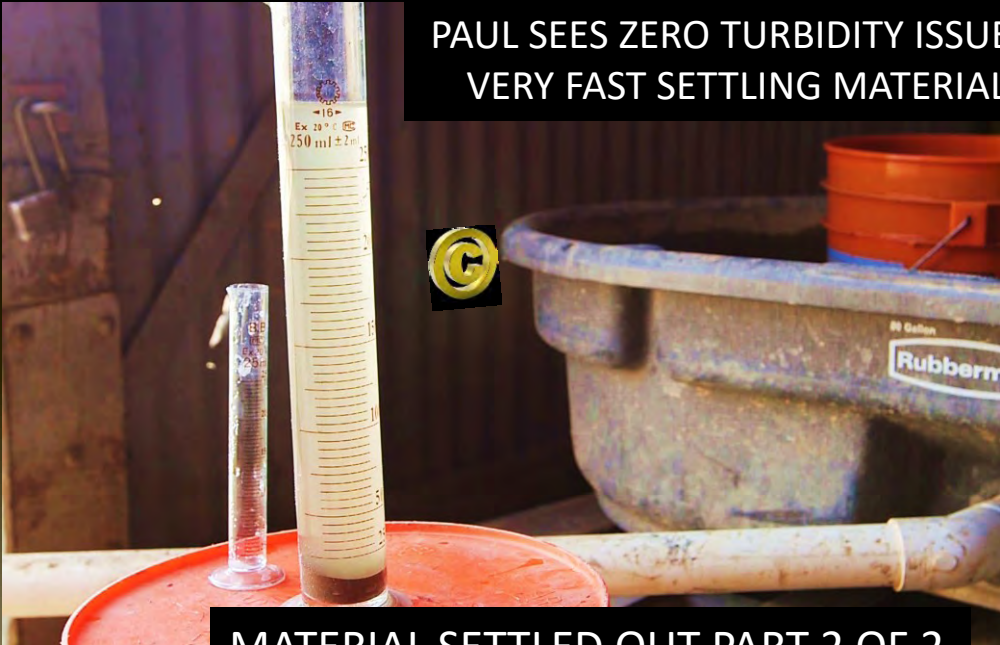

PAUL SEES ZERO TURBIDITY ISSUES- VERY FAST SETTLING MATERIAL

MATERIAL SETTLED OUT PART 2 OF 2



PAUL IS CURIOUS WANTS TO PAN AGAIN



RUNNING THE SPIRAL AT ORO



SPIRAL CLEANER CLOSE UP



RUNNING THE GOLD RICH CORE SAMPLES; PART OF THE 323



GETTING NEAR THE BOTTOM AT ORO OF 323 LBS.



NEAR RUNNING THE LAST OF THE 323 LBS.





AT ORO POURING IN THE "SECOND" BUCKET



EVERYBODY HAPPY AT ORO AFTER FINDING ALL THE GOLD!





*From just one of your pans  
This a fact.*

*David sao marcos*



**EXHIBIT : I**



## ORO INDUSTRIES

*" Your ore is our business "*

Date: November 1, 2019

To Whom it May Concern:

Oro Industries received on June 5, 2019 approximately 323 pounds of core samples delivered from IPOP LLC. We ran this material through a centrifuge and then a spiral concentrator of the same type IPOP intends to use in its Alaska dredging and processing operations as a batch test to confirm that our design for the equipment was consistent with the material to be processed in Alaska.

This process recovered approximately seven grams of gold from the 323 pound sample. We were all very gratified because the process had worked well and the amount of gold recovered was very rich.

Sincerely,

Paul Clift / CEO

Oro Industries Inc.

1203 F St. Marysville, Ca. 95901

paul@oro-industries.com

ph - 530-741-3800

## **Exhibit ;**

### **Safety Sound Conductivity and Temperature Measurements**

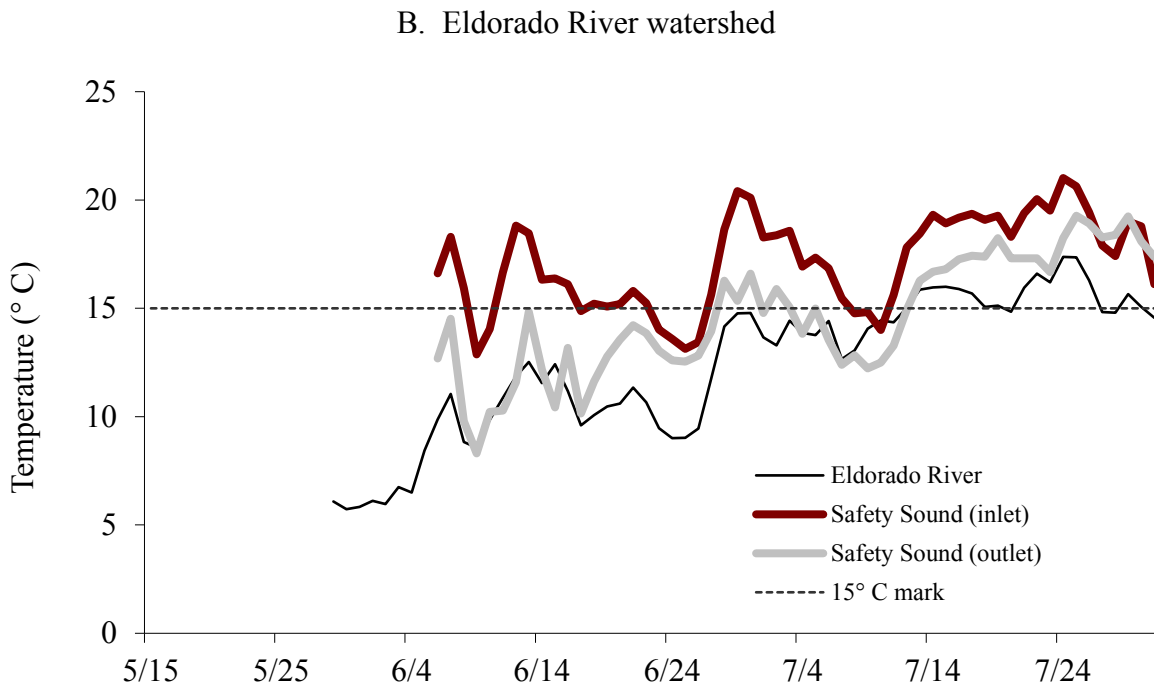
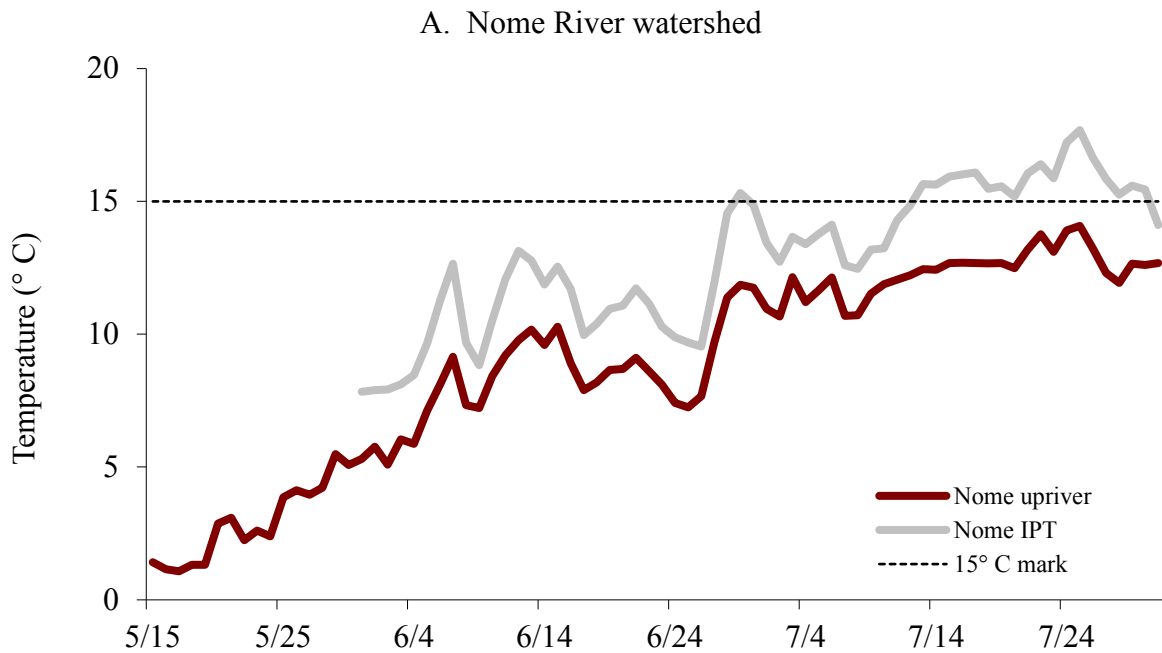

Figure 10. Mean daily temperature from continuous recorders in the (A) Nome River, and (B) Eldorado River watersheds, summer 2004. Dashed line shows 15° C for reference. Data for Nome River (upriver site) and Eldorado River from Kroeker and Dunmall (2005).

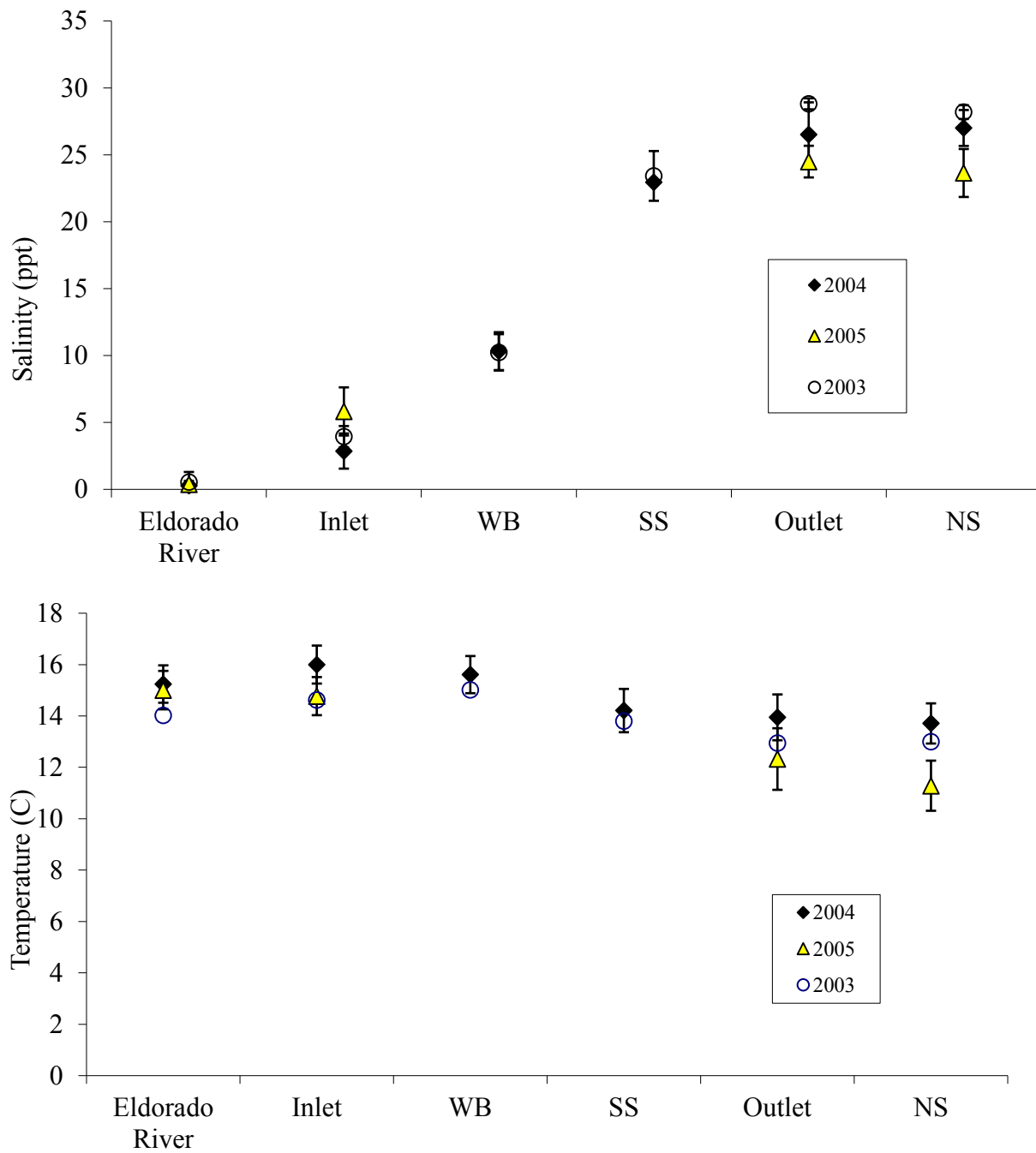

Figure 11. Mean water temperature and salinity throughout Safety Sound, 2003-2005. Sites listed from upstream to downstream. Vertical lines are 1 SE.

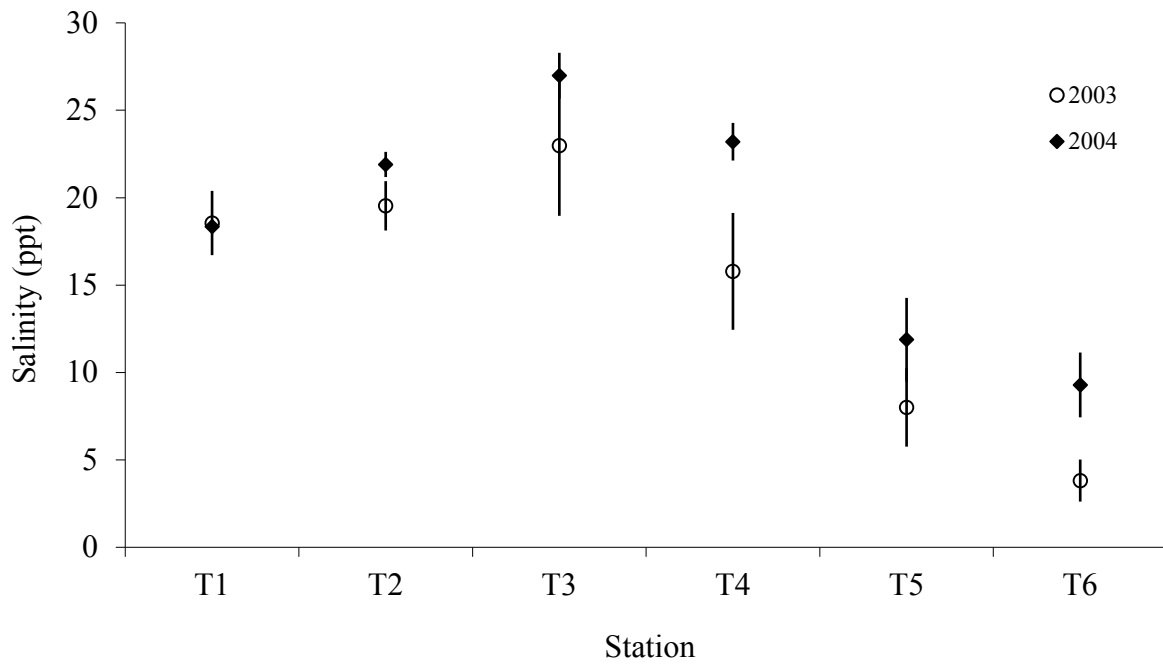
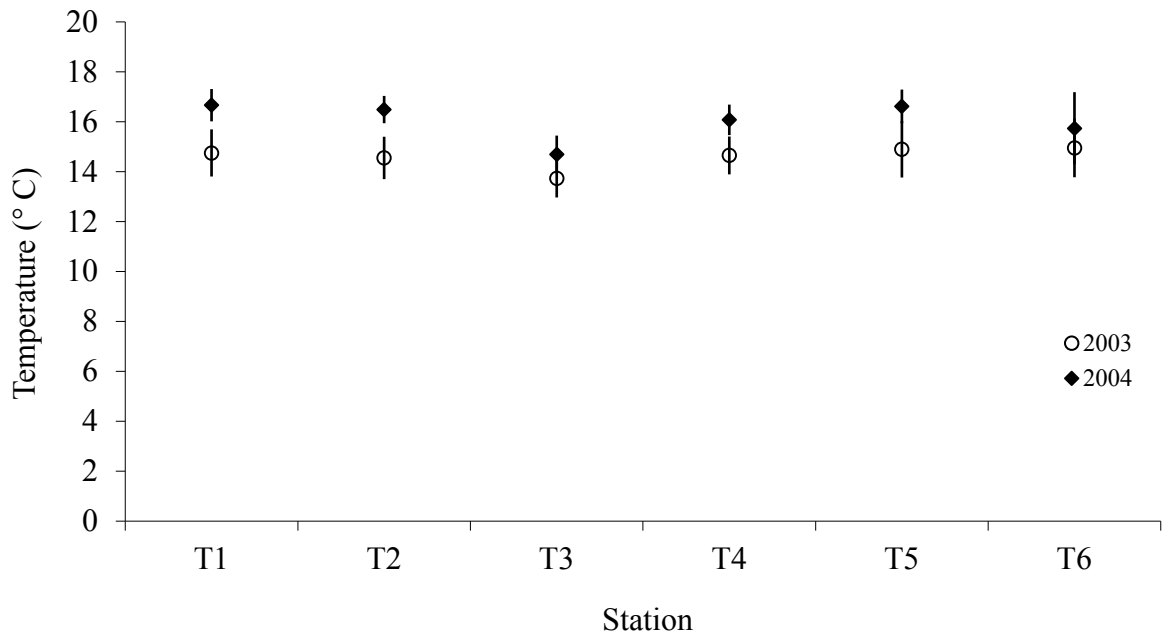

Figure 12. Mean water temperature and salinity across Safety Sound, 2003 and 2004. Stations are listed east to west. Vertical lines are 1 SE. Transects were not performed in 2005.

# **Exhibit 12**

## **Turbidity Curtain Case Studies and Specifications**



# Ruffwater Turbidity Curtain

Golden Gate Bridge  
Installation

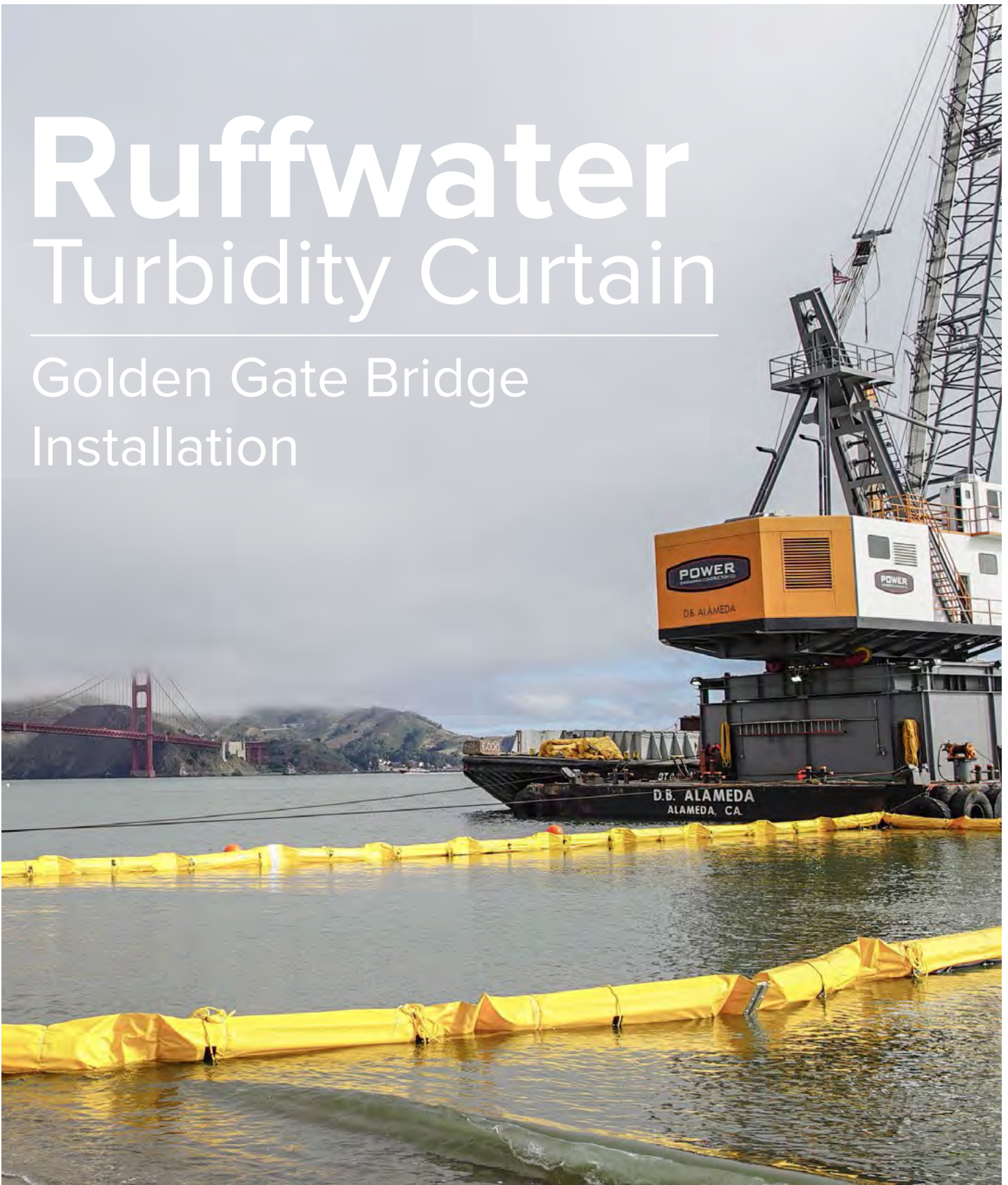

Oil Spill Equipment | Floating Barriers | Incinerators

# The Project:

## Crissy Field Drainage Improvement Project San Francisco, California

---

A stormwater drainage outfall pipe near the Golden Gate Bridge needed to be widened and extended to prevent blockage from sand buildup which contributed to flooding problems upstream in the Crissy Field and Mason Street areas in San Francisco.

### Environmental Impact Mitigation

To protect the fish and marine wildlife, underwater Best Management Practices were established before dredging and repair of the pipe began. An ELASTEC Type III Ruffwater Screen turbidity curtain was installed to minimize construction impacts and silt flow to this sensitive habitat.

### ELASTEC Type III Ruffwater Screen

This is a heavy duty premium turbidity curtain for use in demanding waters such as tidal areas, nearshore ocean environments with strong currents, rivers, bays, harbors and lakes. An ELASTEC Ruffwater Screen controls the migration of silt and turbid water in the construction zone, keeping the surrounding water and marine wildlife safe.

In the Crissy Field project, 500 ft. of the 8 ft. skirt curtain was configured in a “U” shape to encompass the work site. The curtain installation was conducted by Elastec and monitored by the media, California Department of Transportation (Caltrans) and marine biologists. Crissy Field falls under the National Park Service jurisdiction. Powers Engineering Construction was the project contractor.

**“It  
performed  
like a  
champ!”**

*On behalf of Caltrans I would sincerely like to thank you and your crew for our turbidity control curtain. Thank you to the Elastec family for assisting Caltrans in designing a Best Management Practice that has been both cost effective and has exceeded our expectations in performance.*

*Recently I was observing the waves onsite crashing against the shoreline - the winds were so strong they were blowing our plastic covers about; however, the turbidity curtain remained intact and during dredging operations there was no visible notice of turbidity outside of the curtain! It performed like a champ!*

Eltora Charles, Civil T.E.  
California Department of Transportation



926 County Road 1350 N  
Carmi, IL 62821, USA  
Phone: +1 (618) 382-2525  
Fax: +1 (618) 382-3610  
[www.elastec.com](http://www.elastec.com)  
[elastec@elastec.com](mailto:elastec@elastec.com)

RBC-002  
7/27/15

**RUFFWATER SCREEN**

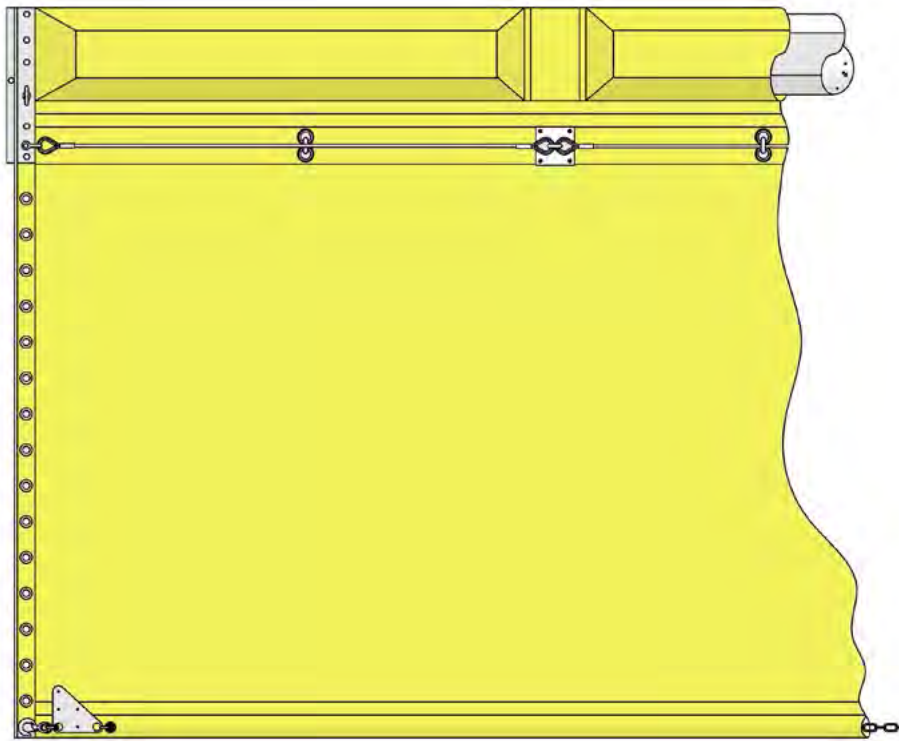

**OPTIONAL RUFFWATER SCREEN MODIFICATIONS**

**FILTER CLOTH**

**REEFING SYSTEM**

**FILTER CLOTH & REEFING SYSTEM**

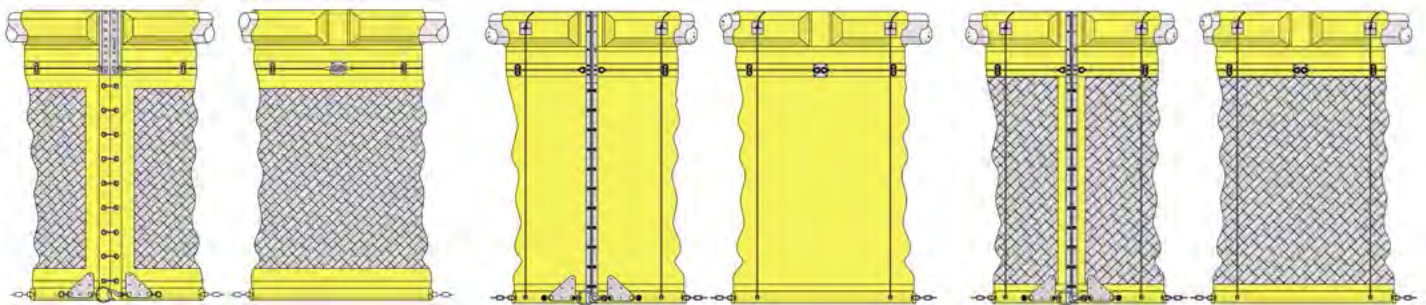

Type III Ruffwater Screen Turbidity Curtain is a heavy duty premium barrier for use in tidal areas or areas where adverse conditions can occur. It is designed for use in demanding water conditions. The curtain intercepts debris and slows the movement of rough water, helping to keep marine habitats safe.

RuffWater Screen is the toughest turbidity curtain for sediment and silt control to protect fragile environmental conditions. The California Department of Transportation's (CALTRAN) Crissy Field Drainage Improvement Project installed the RuffWater Screen to mitigate silt and turbid water in the construction zone. This project has received several environmental awards and recognitions. This curtain is well suited for the construction of bridges, intakes, and pipelines. It is available in permeable and impermeable options.

Section Length	100 ft / 30 m Standard (other lengths available on request)
Draft	3 - 30 ft / xx m (custom depths available on request)
Freeboard	12 inches / xx cm
Flotation Element	12 inch octagonal expanded polystyrene logs placed end to end in the top fabric pocket with separations between logs to allow folding for storage.
Base Fabric	22 oz PVC - Safety Yellow (other colors available) 500 lb/in <sup>2</sup> tensile strength
Permeable Fabric	Bradley Fabrics - Phoenix XL55 (specifications available on request)
Tension Cable	2 each 5/16" galvanized steel cable, with a break strength of 10,540 lbs, is sheathed in vinyl and seamed into the fabric one on each side of the skirt 20" below the flotation. These cables are shackled to the section connectors for uniform tension load transfer.
Ballast	The ballast/tension member is a 3/8", or heavier, galvanized steel chain enclosed in a double layer fabric pocket at the bottom of the skirt. The ballast chain enables the skirt to hang vertically in the water column. The ballast chain is shackled to a stainless steel stress plate at the end of each section. A hook and ring arrangement is provided to transfer the load from one section to the next through the stress plates.
Section Connector	Section of RuffWater Screen are joined together by sliding together the aluminum Universeal connectors that extend from the top of the flotation down the edge of the skirt. Below the connectors, skirts are joined by rope ties between evenly spaced grommets on the skirts. The ballast chain/stress plates are attached via a safety hook and ring. No tools are required.
Anchor Points	Provided every 50 ft. Standard anchoring is 1 anchor every 100' in one directional flow (on upstream side), or 2 every 100' (one on each side) if bi-directional is anticipated. Should flows increase or additional anchors be needed, the points will already be in place 50' OC.
Reefing System (optional)	To raise and lower the curtain skirt. This allows for the system to match the depth requirements of the project exactly.
Optional Items	Marker Buoys, Anchor Systems, Navigational Warning Lights, Repair Kits, Oil Spill Kit, Incinerators, Debris Boom

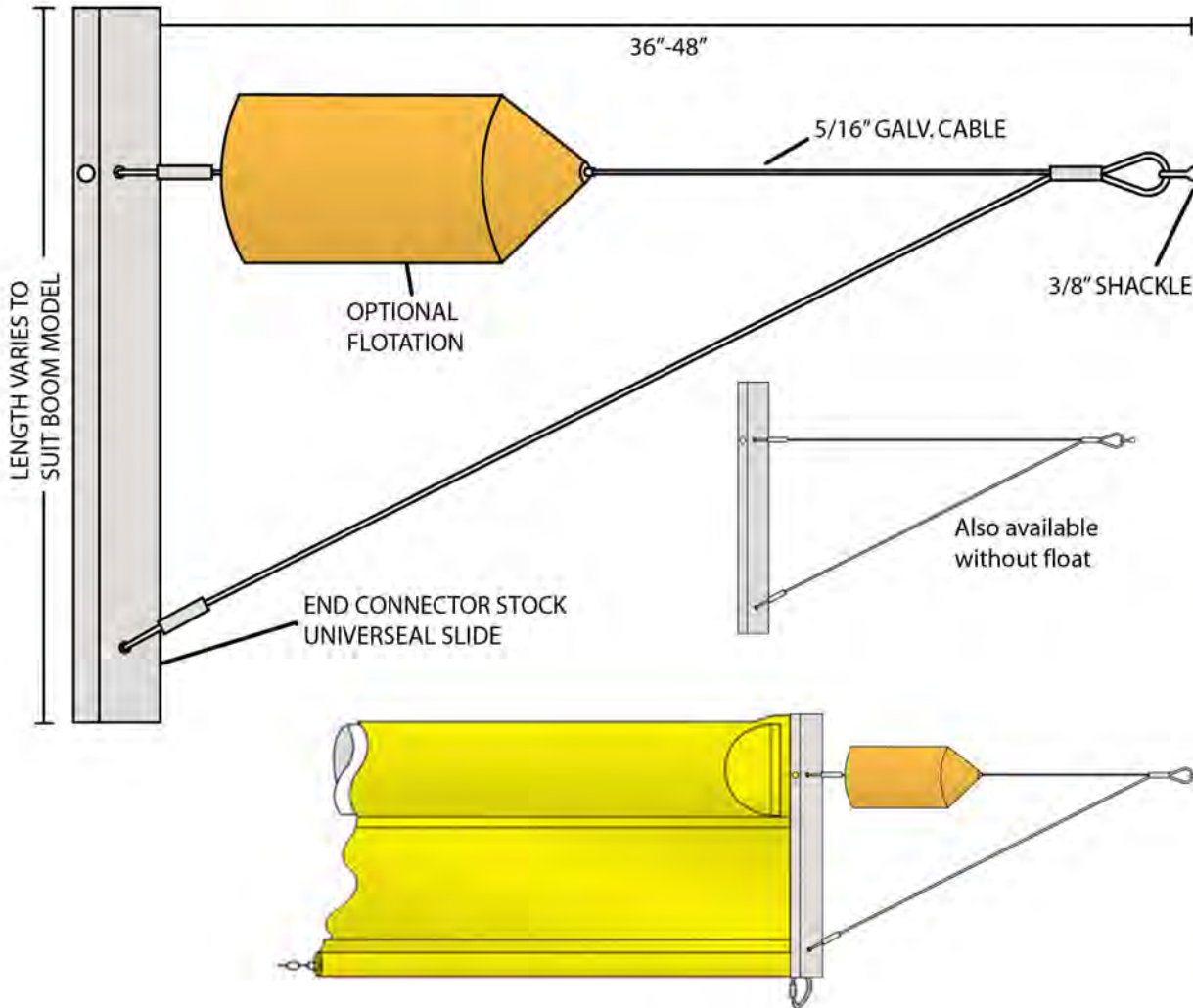

Tow Bridles can be provided with or without auxiliary floats. They may be used for handling the containment boom or silt curtain in water. Prior to deployment, the connector on the tow bridle should be mated to the boom or silt curtain and secured with a toggle pin. The shackle on the tow bridle will accept a line up to 3/4" in diameter. A choice of connectors are available.

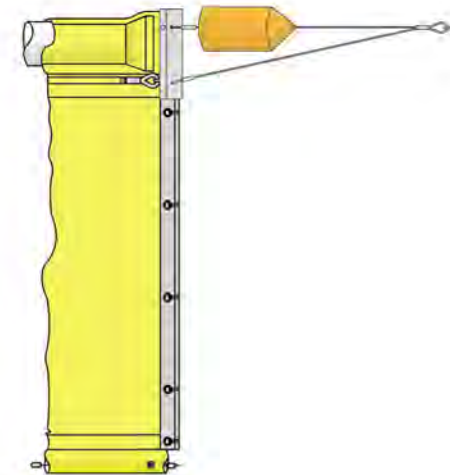

1309 West Main St. Carmi, IL 62821  
Phone: 618-382-2525 Fax: 618-382-3610

401 Shearer Blvd. Cocoa, FL 32922  
Phone: 321-636-5783 Fax: 321-636-5787

Email: [elastec@elastec.com](mailto:elastec@elastec.com) [www.elastec.com](http://www.elastec.com)

Phoenix 55XL

Fabric Property	Unit	Test Method	Minimum Average Roll Values
Fabric Weight	oz/yd <sup>2</sup>	ASTM D-3776	7.4
Thickness	mils	ASTM D-1777	18
Grab Strength (MD/CD)	lbs	ASTM D-4632	350
Grab Elongation (MD/CD)	%	ASTM D-4632	21
Wide Width Tensile	lbs/in	ASTM D4595	225
Wide Width Elongation @ Break	%	ASTM D4595	18
Wide Width Tensile @ 5% Strain	lbs/in	ASTM D4595	80
Wide Width Tensile @ 10% Strain	lbs/in	ASTM D4595	150
Trapezoid Tear Strength (MD/CD)	lbs	ASTM D-4533	125
Puncture Resistance (5/16")	lbs	ASTM D-4833	165
Mullen Burst Strength	psi	ASTM D-3786	695
Vertical Water Flow	gpm/ft <sup>2</sup>	ASTM D-4491	70
Coefficient of Permeability, K	cm/sec	ASTM D-4491	.046
AOS (Mod. to 10 min.)	sieve size	ASTM D-4751	45

MD = Machine Direction  
 CD = Cross Machine Direction

# Reputable case study on effectiveness of bottom sealed turbidity curtain.

Evaluation of Filtering Geotextile Aquatic Filter Barrier Technology for Controlling Suspended Sediments and Turbidity During Dredging, Construction and Demolition

Andrew J. McCusker, C.E.P., Jaret Johnson, P.E.,  
Melissa Hamlin and Christian Guelke  
(Mackworth Group LLC, Scarborough, ME, USA)





## BARRIER TECHNOLOGY

Typically

- **Flexible geotextiles** for in-waterbody filtering, containment, flow training
- **Flotation** to support barrier curtain and maintain integrity at water surface
- **Sealed at sides and bottom** to prevent unfiltered flow

For Some Applications

- Impermeable materials, various mesh sizes
- Fixed frame or structure
- Automated air-cleaning systems with feedback instrumentation





## FULL-DEPTH, SHORE-TO-SHORE ENGINEERED TURBIDITY & FISH EXCLUSION BARRIER

Intertidal Coal Tar Remediation

*Portland Harbor, Maine*



7

## FULL-DEPTH, SHORE-TO-SHORE SYSTEM



- Coal Tar Remediation
  - Voluntary; site of former MGP
  - Intertidal excavation
- AMEC Foster Wheeler Project
  - Mackworth-Enviro provided **turnkey** from design through installation, operation and removal
- **Turbidity and Fish Exclusion Barrier – selected over a temporary sheet pile wall cofferdam**
  - Substantial cost savings
  - Substantial savings to overall schedule
  - Provided partial relief from time-of-year restrictions by excluding winter flounder during spawning season



## FULL-DEPTH, SHORE-TO-SHORE SYSTEM

### Challenges:

- Up to ~15-ft tides; strong tidal currents
- Sudden heavy loads from tanker and tug transit
- Rocky, uneven bottom; rock seawall
- Critical need to contain contaminants
- Threading through old pilings

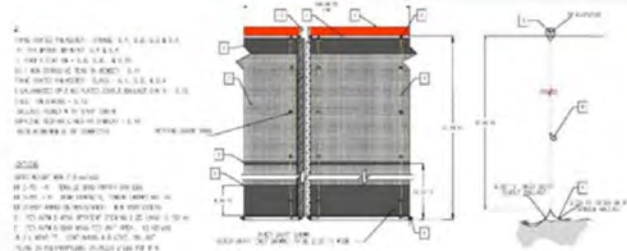

### Solutions:

- 3 layers for strength/filtration, plus sorbent
- Helical anchors for bottom holding strength
- Rock anchors & T-skirt into rock wall shoreline attachment – daisy chain helical anchors added on shore after rock pulled away

## FULL-DEPTH, SHORE-TO-SHORE SYSTEM

### Performance & Lessons Learned:

- No violations
- No sheen or turbidity plume observed outside of barrier
- Water displacement due to tanker with excessive speed pulled rock from seawall
- Barrier remained in place and sealed to bottom throughout.



**Aerial view showing an example of a turbidity curtain effectively containing turbidity on a separate dredging project.**

