

REQUEST FOR QUOTE

MAINTENANCE & OPERATIONS

SPECIFICATIONS & BID DOCUMENTS

PROJECT: Rural Airport Maintenance Service - Ekwok Airport (KEK), Ekwok, AK 99580

CONTRACT NO. 2524C054

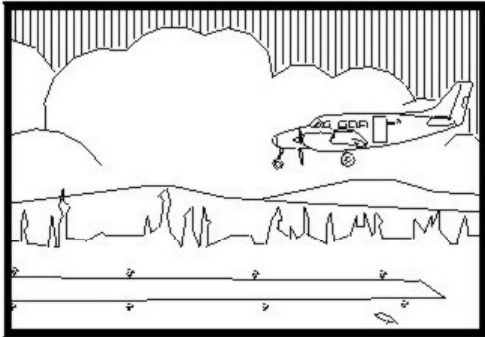

STATE OF ALASKA

Department of Transportation
and Public Facilities

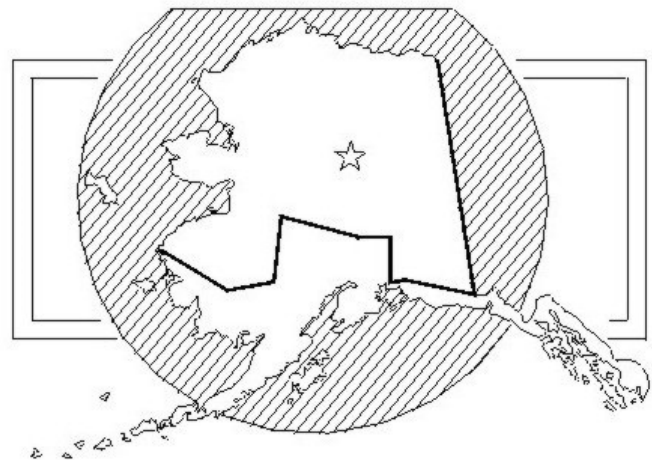
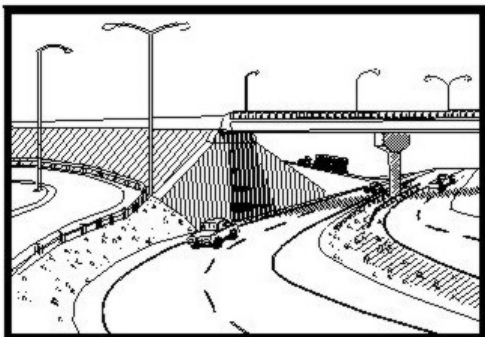

Central Region

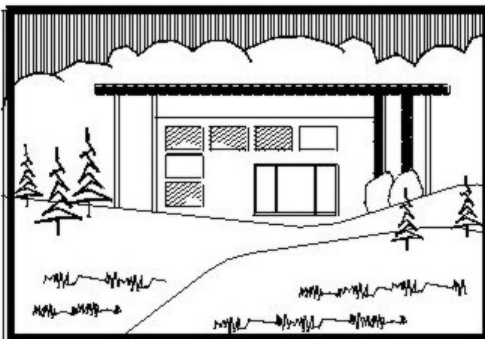

REQUEST FOR QUOTE:Reference Contract No: **2524C054**Date: **01/17/2024****Name and Location of Project:**Rural Airport Maintenance
Ekwok Airport (KEK)
Ekwok, AK 99580**Department or Agency:**State of Alaska
Department of Transportation and Public Facilities
Supply & Services**Procurement Officer:** Ben Wright, Central Region 907-269-0811 ben.wright@alaska.gov**Issuing Office:** Central Region Supply & Services, 2200 E. 42nd Ave, Anchorage, AK 99508**Description of Work:** The work shall consist of routine summer and winter maintenance of the **Ekwok Airport (KEK)** facility, which includes Alaska Department of Transportation, Public Facilities owned maintenance equipment, building structures, and roadways located on airport property unless otherwise designated, in accordance with the contract technical specifications.**Contract Period:** From **Contract award** through **May 7 2024**. No renewals.**BID CLOSING DATE & TIME:** Bids are due before **February 6, 2024 @ 11:00 AM****YOUR ADDRESS & PHONE NUMBER****Project Name & Number:**Rural Airport MaintenanceEkwok, AlaskaRFQ Number: 2524C054State of Alaska
Department of Transportation
& Public Facilities
Central Region Supply & Services
2200 E. 42nd Ave, Anchorage, AK 99508
ATTN: Ben Wright

If Mailing your bid please use the address shown above.

If submitting a quote via email, the quote may be emailed to ben.wright@alaska.gov and must contain the RFQ number in the subject line of the email. The **maximum** size of a single email (including all text and attachments) that can be received by the state is **10mb (megabytes)**. If the email containing the quote exceeds this size, the quote must be sent in multiple emails that are each less than 10 megabytes and each email must comply with the requirements described above.

Please note that email transmission is not instantaneous. Similar to sending a hard copy quote, if you are emailing your quote, the state recommends sending it ahead of time to ensure the email is delivered by the deadline for receipt of bids.

It is the vendor's responsibility to contact the issuing agency at **907-269-0811** to confirm that the quote has been received. The state is not responsible for unreadable, corrupt, or missing attachments. Confidentiality can only be assured for sealed quotes.

Quotes transmitted by mail must be received at the above-specified address no later than the scheduled time of quote opening. Emailed or faxed quotes, amendments or withdrawals must be received by the Procurement Officer listed on this RFQ, prior to the scheduled time of quote opening. Facsimile communications must be addressed to **Ben Wright at** Fax No. **(907) 269-0872**. Faxes must include a cover letter that contains all of the information required on the envelope of mailed quotes.

NOTICE TO BIDDERS

Bidders are hereby notified that data to assist in preparing bids is available as follows:

The Contractor is hereby notified that all records pertaining to the development of this project are available for inspection at the Department of Transportation and Public Facilities

Plans and Specifications may be obtained upon request from:

State of Alaska
Department of Transportation & Public Facilities
Central Region Supply & Services
2200 E. 42nd Ave, Anchorage, AK 99508
Attn: **Ben Wright**
Phone: (907) **269-0811**
ben.wright@alaska.gov

All questions concerning bidding procedures should be directed to the Procurement Officer.

Bidders requesting assistance, either in viewing the project or obtaining pre-bid information, must make arrangements at least 24 hours in advance with the Procurement Officer:

Attn: **Ben Wright**
Phone: (907) **269-0811**
ben.wright@alaska.gov

REQUIRED FOR BID & AWARD

SEE PAGE 10 of this RFQ for Required documents

CENTRAL REGION MAINTENANCE & OPERATIONS RURAL AIRPORT MAINTENANCE**INSTRUCTIONS TO BIDDERS**

1. SPECIAL INFORMATION
 - A. Location: Ekwok Airport (KEK) Ekwok, Alaska 99580
 - B. Equipment: Equipment at this location shall be: **State Furnished.**
 - C. Job Site Visit: Bidders are strongly encouraged to visit the work site(s) prior to the scheduled bid opening to inform themselves of all conditions under which work is to be performed.

2. Bidders are requested to carefully review this RFQ. Questions, objections or comments should be made in writing and received by the Procurement Officer no later than three (3) days prior to the Bid Opening, so that any necessary amendments may be published and distributed to bidders to prevent the opening of a defective bid upon which award cannot be made, but which will result in the exposure of bidders' prices. Bidders' pretests based upon any omission, or errors, or the content of the Invitation for Bids may be disallowed if not made known prior to the Bid Opening.

Do not put the bid number and opening date on the envelope if you are requesting bid information. Envelopes with bid numbers will not be opened until the scheduled date and time. Do not include in the envelope any bids for other work.

3. Pursuant to AS 36.30.560 and AS 36.30.565 an interested party may protest award of this contract. The protest shall be filed with the Procurement Officer in writing and include the following information:
 - (1) Name, address and telephone number of the protester;
 - (2) The signature of the protester or the protester's representative;
 - (3) Identification of the contracting agency and the solicitation or contract at issue;
 - (4) A detailed statement of the legal and factual grounds of the protest, including copies of relevant documents;
 - (5) The form of relief requested.
 - (6) The protest must be filed within 10 days after a notice of Intent to Award the contract is issued.

4. PREPARATION OF BIDS
 - A. Bidders are instructed to use the attached bid forms for submitting bids. Bids shall be submitted on the forms furnished or copied there of, and must be

manually signed in ink. If erasures or other changes appear on the forms, each such erasure or change must be initialed by the person signing the proposal. The bidder shall specify in form proposal a price in figures.

- B. Conditional or alternative bids will be rejected as non-responsive.
- C. Bids, amendments or withdrawals may be submitted by fax, emailed, or mailed in a sealed envelope. Confidentiality can only be assured for sealed quotes.
- D. FIRM OFFER: For the purpose of award, offers made in accordance with this RFQ must be good and firm for a period of ninety (90) days from the date of bid closing.

5. BIDDERS QUALIFICATIONS

Before a bid is considered for award, the bidder may be requested by the Department to submit a statement of facts, in detail, as to Bidder's previous experience in performing comparable work, the Bidder's business and technical organization, financial resources, and equipment available to be used in performing the contemplated work.

COMPLIANCE: In the performance of a contract that results from this RFQ, the contractor must comply with all applicable federal, state, and borough regulations, codes, and laws; and be liable for all required insurance, licenses, permits and bonds; and pay all applicable federal, state, and borough taxes.

Prior to award of the contract, a State representative may inspect the equipment the Bidder proposes to use in fulfilling his obligations under the contract. If, at the discretion of the inspector, the equipment is determined to be inadequate to perform the contract, the Bidder shall be given a five (5) day correction period to repair or replace the equipment and to be re-inspected. Failure after the second inspection will result in rejection of the bid and award will be made to the next lowest bidder, subject to inspection as stipulated above.

DEFAULT: In case of default by the contractor, for any reason whatsoever, the State of Alaska may procure the goods or services from another source and hold the contractor responsible for any resulting excess cost and may seek other remedies under law or equity.

CONTINUING OBLIGATION OF CONTRACTOR: Notwithstanding the expiration date of a contract resulting from this RFQ, the contractor is obligated to fulfill its responsibilities until warranty, guarantee, maintenance and parts availability requirements have completely expired.

ALASKA BUSINESS LICENSE AND OTHER REQUIRED LICENSES: Prior to the award of a contract, a bidder must hold a valid Alaska business license.

Bidders should contact the Department of Commerce, Community and Economic Development, Division of Corporations, Business, and Professional Licensing for information on these licenses.

Website:

<https://www.commerce.alaska.gov/web/cbpl/ProfessionalLicensing.aspx>

Phone: (907) 465-2550

Email: license@alaska.gov

Acceptable evidence that the bidder possesses a valid Alaska business license may consist of any one of the following:

- (a) copy of an Alaska business license;
- (b) certification on the bid that the bidder has a valid Alaska business license and has included the license number in the bid (see front page);
- (c) a canceled check for the Alaska business license fee;
- (d) a copy of the Alaska business license application with a receipt stamp from the state's occupational licensing office; or
- (e) a sworn and notarized statement that the bidder has applied and paid for the Alaska business license.

The Department reserves the right to disqualify a bidder or refuse to issue an award for any of the following reasons:

- A. Uncompleted work of a bidder which, in the judgment of the Department, might hinder or prevent the prompt completion of additional work if awarded.
- B. Failure to pay, or satisfactorily settle, all bills due for labor and material on previous contracts in force at the time of issuance of proposals.
- C. Failure to comply with any qualification requirements of the Department.
- D. Default under previous contracts, or fraud or dishonesty in the performance of previous contracts.
- E. Unsatisfactory performance on previous work.
- F. Failure to reimburse the State for monies owed on any previous contracts.
- G. More than one bid for the same work from an individual, firm, or corporation under the same or different name.
- H. Evidence of collusion among bidders. Participants in such collusion will receive no recognition as bidders for any future work of the Department until any such participant shall have been reinstated as a qualified bidder.

Nothing contained in this section shall deprive the Department of its discretion in the matter of determining the lowest responsive, responsible bidders.

6. SUBMISSION OF BIDS

All bids including any amendments or withdrawals must be received prior to bid closing. Bids shall be submitted on the form furnished and must be in a sealed envelope marked and addressed as follows:

YOUR ADDRESS AND PHONE NUMBER

Ekwok Airport Maintenance

Bid Number: **2524C054**

Bid amendments or withdrawals may be submitted by fax, emailed, or mailed in a sealed envelope. Confidentiality can only be assured for sealed quotes. Bids transmitted by mail must be received at the above specified address no later than the scheduled time of bid opening. Facsimile communications must be addressed to **Ben Wright, FAX No. (907) 269-0872.**

7. RECEIPT AND OPENING OF BIDS

- A. All bids, including any amendments, must be received by the Department prior to the scheduled time of Bid Opening. Any bid, or amendments which have not been actually received by the Department prior to the time of the scheduled bid opening will not be considered.
- B. QUOTE REJECTION: The State reserves the right to reject any or all quotes, combinations of items, or lot(s), and to waive defects or minor informalities.
- C. This is an informal quotation that will not be read at public opening. The information may be publicly reviewed after award. The terms and conditions should be reviewed and understood before preparing a quotation. The quotation shall be the best net price. Return the quotation and the Bid Schedule by the above time and date to the above address. Please reference the Procurement Officer's name and the RFQ number on the outside of the return envelope, fax cover page or email.

8. WITHDRAWAL OF BIDS

Bids may be withdrawn by written email or fax request received from a bidder prior to the time fixed for opening. Negligence on the part of the bidder in preparing the bid confers no right for the withdrawal of the bid after it has been opened.

9. MORE THAN ONE BID

If more than one bid is offered by any one party, by or in the name of his or their clerk or partner, all such bids will be rejected. A party who has quoted prices to a bidder is not thereby disqualified from quoting prices to other bidders or from submitting a bid directly for the work.

10. REJECTION OF BIDS

The Department reserves the right to reject any and all bids when such rejection is deemed by the Procurement Officer to be in the best interest of the State; to reject the bid of a bidder who has previously failed to perform properly, or complete on time, contract of a similar nature; to reject the bid of a bidder who is not, in the opinion of the Procurement Officer, in a position to perform the Contract; and to reject a bid as non-responsive where the bidder fails to furnish the required documents listed on the Required Document Page, fails to complete required documents in the manner directed, makes unauthorized alterations to the bid documents, or is otherwise determined to be an unqualified bidder.

11. AWARD OF CONTRACT

- A. The Contract Award, if the Contract is to be awarded, will be issued to the lowest responsive, responsible, and qualified bidder as soon as practical.
- B. All bidders will be notified of the Department's Intent to Award the Contract and the successful Bidder will be requested to execute certain documents, including, but not limited to, the Contract form.
- C. The Contract will be awarded to the successful bidder following receipt by the Department of all required documents, properly executed, within the time specified in the Intent to Award.

12. SUBCONTRACTOR(S): Within five (5) working days of notice from the state, the apparent low bidder must submit a list of the subcontractors that will be used in the performance of the contract. The list must include the name of each subcontractor and the location of the place of business for each subcontractor and evidence of each subcontractor's valid Alaska business license.

The Contractor may replace a listed Subcontractor who:

- (1) Fails to comply with AS 08.18;
- (2) Files for bankruptcy or becomes insolvent;
- (3) Fails to execute a contract with the Bidder involving performance of the work for which the Subcontractor was listed and the Bidder acted in good faith;
- (4) Fails to obtain bonding, if required;
- (5) Fails to obtain insurance acceptable to the Department, if required;
- (6) Fails to perform the Contract with the Bidder involving work for which the Subcontractor was listed;

- (7) Must be replaced in order for the prime Contractor to satisfy required State and/or Federal affirmative action requirements;
- (8) Refuses to agree or abide with the Bidder's labor agreement; or
- (9) Is determined by the Procurement Officer not to be responsible.

A bidder who attempts to circumvent the requirements of AS 36.30.115 by listing as a subcontractor another who, in turn sublets the majority of the work required under the contract violates AS 36.30.115.

If the contract is awarded to a bidder who violates this section, the Procurement Officer may:

- (1) cancel the contract; or
- (2) assess a penalty on the bidder

13. ALASKA BIDDERS PREFERENCE

The award of a contract based on a Request for Quotation (RFQ) will be made to the lowest responsive and responsible bidder after an Alaska bidder preference of five percent (5%) has been applied. An "Alaska bidder" is a person who: (1) holds a current Alaska business license; (2) submits a bid for goods, services, or construction under the name as appearing on the person's current Alaska business license; (3) has maintained a place of business within the state staffed by the bidder or an employee of the bidder for a period of six months immediately preceding the date of the bid; (4) is incorporated or qualified to do business under the laws of the state, is a sole proprietorship and the proprietor is a resident of the state, is a limited liability company organized under AS 10.50 and all members are residents of the state, or is a partnership under AS 32.06 or AS 32.11 and all partners are residents of the state; and, (5) if a joint venture, is composed entirely of ventures that qualify under (1) (4) of this subsection. AS 36.30.170, AS 36.30.321(a) and AS 36.30.990(2)

14. ALASKA VETERAN PREFERENCE: If a bidder qualifies for the Alaska bidder preference under AS 36.30.321(a) and AS 36.30.990(2) and is a qualifying entity as defined in AS 36.30.321(f), they will be awarded an Alaska veteran preference of five percent (5%). The preference will be given to a (1) sole proprietorship owned by an Alaska veteran; (2) partnership under AS 32.06 or AS 32.11 if a majority of the partners are Alaska veterans; (3) limited liability company organized under AS 10.50 if a majority of the members are Alaska veterans; or (4) corporation that is wholly owned by individuals and a majority of the individuals are Alaska veterans, and may not exceed \$5,000. The bidder must also add value by actually performing, controlling, managing, and supervising the services provided, or for supplies, the bidder must have sold supplies of the general nature solicited to other state agencies, other governments, or the general public. AS 36.30.321(i)

REQUIRED DOCUMENTS:

Required for Bid

Bids will not be considered if the following documents are not completely filled out and submitted at the time of bid closing.

1. Proposal Form, (prices are to be entered on this document and page 2 must be signed).
2. Non-Collusion Declaration Form (1-page)
3. Contractor's Questionnaire (3-pages)

Required for Award

In order to be awarded the contract, the successful bidder must completely fill out and submit the following documents within the time specified in the Intent to Award letter:

1. Proof of Insurance (if using own equipment/vehicles)
2. Alaska Business License
3. Subcontractor List (if applicable)
4. List of Equipment (if using your own equipment)

CONTRACTOR'S QUESTIONNAIRE**CONTRACT NAME:** Airport Maintenance Service – **Ekwok APT (KEK), Ekwok, AK 99580****RFQ NUMBER:** **2524C054**

Contractor shall provide complete and adequate information to the questions set forth below, to facilitate a determination of responsiveness and responsibility.

Contractors are to use supplemental pages if needed, to provide complete responses to the questions asked. General statements such as "As Required" or "As Needed" are NOT considered complete or adequate responses.

All information is considered essential, failure to provide a response to any of the line items may find the bidder nonresponsive and the bid may be rejected.

1. Name of Firm/Business: _____
- Authorized Signature: _____
- Mailing Address: _____
- Location Address: _____
- Email Address: _____
- Contact Number(s) Business/Home/Cell: _____
- Vendor Tax I.D or SSN: _____
- Alaska Business License Number: _____

Type of Business: (Please check One)

	<u>TITLE</u>	<u>NAME</u>
_____ Sole Owner	_____	_____
_____ Partnership	_____	_____
_____ Joint Venture	_____	_____
_____ Corporation (Membership Organization)	_____	_____

2. List all personnel in the company and their work experience in the performance of Airport Maintenance Services (if applicable):

3. Is Airport Maintenance Services a Full Time _____ or a Part Time _____ business of the Bidder? (Please check One)

4. Airport Maintenance Contracts currently being performed by the Bidder (if applicable):

Contract Description _____

Reference Contact _____ (Required); Telephone No. _____ (Optional)

Contract Description _____

Reference Contact _____ (Required); Telephone No. _____ (Optional)

Contract Description _____

Reference Contact _____ (Required); Telephone No. _____ (Optional)

All other Contracts performed by the Bidder during the past two years (if applicable):

Contract Description _____

Reference Contact _____ (Required); Telephone No. _____ (Optional)

Contract Description _____

Reference Contact _____ (Required); Telephone No. _____ (Optional)

Contract Description _____

Reference Contact _____ (Required); Telephone No. _____ (Optional)

<h1>PROPOSAL</h1>		SOLICITATION NO. 2524C054		
		Date:		
NAME AND ADDRESS OF CONTRACTOR:		CHECK APPROPRIATE BOX <input type="checkbox"/> Sole Owner/Individual <input type="checkbox"/> Partnership <input type="checkbox"/> Incorporated in the state of <input type="checkbox"/> Joint Venture		
DEPARTMENT OR AGENCY: State of Alaska, Department of Transportation and Public Facilities				
CONTRACT FOR (Work to be performed): The routine summer and winter maintenance of the airport facility which includes Alaska Department of Transportation and Public Facilities owned maintenance equipment, building structures, and roadways located on airport property unless otherwise designated.				
LOCATION: Ekwok APT (KEK), Ekwok, AK 99580				
Description	Quantity	Unit of Measure	Monthly Unit Price	Total Price (Qty x unit price)
Ekwok Airport (KEK) Rural AIRPORT MAINTENANCE	3	Months	\$ _____	\$ _____
<p>THIS CONTRACT, entered into this date by the State of Alaska, hereinafter called the State, represented by the Procurement Officer executing this contract, and the individual, partnership, or corporation named above, hereinafter called the Contractor, witness that the parties hereto do mutually agree as follows:</p> <p>STATEMENT OF WORK: The Contractor shall furnish all labor, and if required, equipment and materials, and perform the work above described for the amount stated above in strict accordance with the specifications and conditions all of which are made a part hereof and designated as follows:</p> <p>CONTRACT PERIOD: Date of award Approximately February 7, 2024 through May 7, 2024.</p> <p>AIRPORT MANAGER: Jon Taylor PHONE: (907) 842-5511 EMAIL: jon.taylor@alaska.gov</p>				
CONTRACT EFFECTIVE DATE: Date of award			CONTRACT EXPIRATION DATE: May 7, 2024	

In witness whereof, the parties hereto have executed this contract as of the date entered on the first page hereof.

STATE OF ALASKA

CONTRACTOR

By: _____
(Signature)

By: _____
(Signature)

(Typed or Printed Name)

(Typed or Printed Name)

(Title)

(Title)

(Date)

(Date)

INSTRUCTIONS

1. This form shall be used, as required by State regulations, for contracts for the construction, alteration, or repair of public buildings or works.
2. The full name and business address of the Contractor must be inserted in the space provided on the face of the form. The Contractor shall sign in the space provided above with his usual signature and typewrite or print name under all signatures to the contract and bonds.
3. An officer of a corporation, a member of a partnership, or an agent signing for the Contractor shall place his signature, typed or printed name, and title after the word "By" under the name of the Contractor. A contract executed by an attorney or agent on behalf of the Contractor shall be accompanied by two authenticated copies of his power of attorney, or other evidence of his authority to act on behalf of the Contractor.

NON-COLLUSION DECLARATION

The Undersigned declares, under penalty of perjury under the laws of the United States, that neither he nor the firm, association or corporation of which he is a member, a bidder on this project has, either directly or indirectly, entered into any agreement, participated in any collusion, or otherwise taken any action in restraint of free competitive bidding in connection with this bid.

The Undersigned has read the foregoing proposal and hereby agrees to the conditions stated therein by affixing his signature below:

Company Name or Contractor

Signature

Printed Name

Title of Person Signing

Phone Number

Fax Number (if applicable)

Email address

This document must be completed and returned with your bid in order to be considered responsive. Any submitted bids that do not include this signed document may be rejected.

CENTRAL REGION MAINTENANCE & OPERATIONS AIRPORT MAINTENANCE CONTRACT

GENERAL PROVISIONS & TECHNICAL SPECIFICATIONS

(I) SCOPE OF WORK

The Work shall consist of routine summer and winter maintenance of the **Ekwok Airport (KEK)** facility which includes Alaska Department of Transportation and Public Facilities owned maintenance equipment, building structures, and roadways located on airport property unless otherwise designated.

During the course of this agreement and in accord with the terms of this contract, the Contractor will coordinate with and take direction from the Department representative or his/her designee for the area as identified in the letter of "Notice to Proceed". This is an integrated contract between the Department and the Contractor. All other agreements, whether oral or written, are merged into this contract. This contract may only be amended in writing. This contract is severable, if one provision of this contract is found to be unenforceable; it shall not relieve the Contractor from performing all other provisions of this Contract.

(II) CONTRACT WORK AREA

All state runways, taxiways, aprons, safety areas, state access roads, lighting systems, segmented circles, wind cones and State buildings at the Airport. It is the Contractor's responsibility to contact the airport manager (Department representative) to clarify the work area boundaries.

(III) CONTRACT PERIOD

The Contract period shall be from **Date of award** through **May 7, 2024**.

(IV) SERVICE PERIOD

The Contractor shall perform all duties necessary to maintain and operate the **Ekwok Airport** during the Contract. The airport shall be kept accessible ***7 days a week, 365 day a year***, unless an emergency or routine maintenance prevents the airport from being open. To the greatest extent practical, the Contractor is to provide that level of performance, which will insure the safe movement and convenient use of the airport by the public. The runway is to remain operational in the event of an emergency or MEDIVAC.

(V) CONTRACTOR AND EMPLOYEE QUALIFICATION

Contractor, subcontractors, and all employees must be capable and experienced and/or have the skills/ability to perform in the operation of heavy equipment and airport operations. The Contractor shall submit a list of personnel who will be operating the equipment. At any time, the Department reserves the right to require the Contractor, subcontractors, and all employees demonstrate skills/ability to successfully operate the State equipment prior to operating equipment. The Department reserves the option to conduct an equipment operation test of any person operating the State equipment prior to award in order to determine competency. The Department reserves the right to require the removal of any worker from the work area whom it deems incompetent, insubordinate, or otherwise objectionable. The Department reserves the option to not award a contract based on the Department's historical knowledge of the bidder's past performance.

The Contractor shall take measures to comply with Alaska Statute 28.35.161 – "Use of electronic devices while driving; unlawful installation of television, monitor, or similar device.

(VI) SERVICE CONTRACT DEFICIENCIES

The contractor's failure to provide a service required by this contract will be grounds for the state to issue a Service Deficiency Claim (SDC) to the contractor. The SDC will be provided to the contractor in writing. The contractor will advise the state, in writing, of the corrective action being taken. If a deficiency is not corrected within 7.5 working hours from the time it is issued, the state may issue another SDC and procure, from another contractor, the services necessary to correct the problem. The contractor will then be obligated to reimburse the state for the amount required to correct the problem. If a contractor gets more than two substantiated SDC's in a 45-day period or a total of 4 substantiated SDC's in a 90-day period it will be grounds for the state to declare the contractor in default.

(VII) EQUIPMENT

The Contractor shall contact the Airport Manager or District Superintendent and inquire about the use of existing Department equipment, at this location, that is available for the Contractor's use to perform the required airport maintenance. All State furnished equipment shall be used for the sole purposes of performing this contract in accordance with the contract work areas. The Contractor shall exercise a high standard of care of all State equipment. Working equipment is paramount for the execution of this contract. The Department reserves the right to terminate the contract for failure to comply or damage beyond normal wear and tear to any equipment. The Contractor shall place signs approved by the Airport Manager on the Snow Removal Equipment Building (SREB) and State equipment stating "Only persons authorized by DOT&PF shall operate State Equipment". It shall be the Contractor's responsibility to provide all the equipment necessary to perform maintenance in accordance with this contract whether it is supplied by the Department or the Contractor.

(VIII) REPRESENTATIVE

The Contractor or a competent Representative will be available to the job site at all times during the period of the contract. A competent representative must be empowered to act for the Contractor and must be fluent in both written and spoken English to adequately perform the contracted services. The Contractor shall furnish and update as appropriate a telephone number of dependable means by which the Contractor or his authorized representative can be contacted within a reasonable length of time in order to respond to an unusual condition or accident at the airport. If the Contractor has a representative to perform daily maintenance, the Contractor (principal officer) must personally perform one on-site inspection every two- (2) weeks from November 1 to April 30 and monthly inspections for the remainder of the year. Failure to do so may result in the termination of the contract. When the Contractor absents himself from his normal place of business, so as to make himself unavailable to the Department, the Contractor shall, prior to absenting himself, provide the Department representative with the business and/or personal telephone numbers of a competent/qualified person who has full authority to act for the Contractor in the conduct of this contract.

(IX) AUTHORITY OF DEPARTMENT REPRESENTATIVE

The Department Representative or his/her designees shall address any and all questions which may arise as to the quality and acceptability of work performed. The Department Representative shall decide on all questions, which may arise as to the interpretation of the specifications or plans relating to the work, and the fulfillment of the contract on the part of the Contractor.

(X) INSPECTION OF WORK

All materials and each part or detail of work shall be subject to inspection by the Department Representative or his/her designee. The Department Representative shall be allowed access to all parts of the work and shall be furnished with such information and assistance by the Contractor as is required to make a complete and detailed inspection.

(XI) DEFECTIVE WORK (DAMAGE AND PROTECTION)

Deficiencies in the work observed during inspection of the facility by the Department will be brought to the Contractors attention by written notification. The Contractor shall, at its own expense, immediately remedy and correct any defect in its work when the defect is brought to the Contractor's attention, whether by written notice from the Department or otherwise. The Contractor must coordinate with the Department representative and obtain approval of all replacement materials to ensure system compatibility and conformance to specifications. If the Contractor fails to correct a deficiency within the time set forth by the Department representative, the Department may terminate the contract and/or obtain the contract services from other

sources and hold the Contractor responsible for any excess costs occasioned thereby, and may deduct these costs from any payments due the Contractor.

If the Department determines the Contractor has presented a hazardous situation that could result in injury to the public and/or Department employees, the Department may immediately correct the deficiency at the Contractor's expense, using either Department employees or a private contractor, and may deduct the costs incurred from moneys owed the Contractor.

(XII) EXCLUSION

- A. Work stipulated in this contract is not required on State land, which is leased to another party. When such areas are under the control of a lessee, the lessee is responsible for maintaining all aircraft maneuvering surfaces on the leased property.
- B. No work is required for the repair of radio operated electrical devices, with the exception of fuse replacement, circuit breaker resetting, and bulb replacement.

(XIII) INDEMNIFICATION

A. The Contractor shall indemnify, hold harmless, and defend the contracting agency from and against any claim of, or liability for error, omission or negligent act of the Contractor under this agreement. The Contractor shall not be required to indemnify the contracting agency for a claim of, or liability for, the independent negligence of the contracting agency. If there is a claim of, or liability for, the joint negligent error or omission of the Contractor and the independent negligence of the Contracting agency, the indemnification and hold harmless obligation shall be apportioned on a comparative fault basis. "Contractor" and "Contracting agency", as used within this and the following article, include the employees, agents and other Contractors who are directly responsible, respectively, to each. The term "independent negligence" is negligence other than in the Contracting agency's selection, administration, monitoring, or controlling of the Contractor and in approving or accepting the Contractor's work.

B. Without limiting Contractor's indemnification, it is agreed that Contractor shall purchase at its own expense and maintain in force at all times during the performance of services under this agreement the policies of insurance listed in Section (XIII) of this contract. Where specific limits are shown, it is understood that they shall be the minimum acceptable limits. If the Contractor's policy contains higher limits, the state shall be entitled to coverage to the extent of such higher limits. Certificates of Insurance must be furnished to the Procurement Officer prior to beginning work and must provide for notice of cancellation, nonrenewal or material change of conditions in accordance with policy provisions. Failure to furnish satisfactory evidence of insurance or lapse of the policy is a material breach of this contract and shall be grounds for termination of the Contractor's services. All insurance policies shall comply with, and be issued by insurers licensed to transact the business of insurance under AS 21.

(XIV) INSURANCE REQUIREMENT

The Contractor shall provide evidence of insurance with a carrier or carriers satisfactory to the Department covering injury to persons and/or property suffered by the State of Alaska or a third party, as a result of operations under this contract by the Contractor or by any subcontractor. This coverage will also provide protection against injuries to all employees of the Contractor and the employees of any subcontractor engaged in work under this contract. The delivery to the Department of a written notice is required before cancellation of any coverage or reduction in any limits of liability in accordance with policy provisions.

The Contractor shall maintain in force at all times, during the performance of work under this contract, the following policies of insurance. All insurance policies shall comply with, and be issued by insurers licensed to transact the business of insurance under AS 21. Failure to maintain the specified insurance may, at the option of the Procurement Officer, be deemed as breach of contract. Where specified limits and coverages are shown, it is understood that they shall be the minimum acceptable. Additional insurance requirements specific to this contract are contained in the Invitation for Bid, when applicable.

Workers' Compensation Insurance: The Contractor shall provide and maintain, for all employees engaged in work

under this contract, coverage as required by AS 23.30.045, and; where applicable, any other statutory obligations including but not limited to Federal U.S.L. & H. and Jones Act requirements. The policy must waive subrogation against the State of Alaska. If the Contractor does not have any employees, then the contractor shall provide a written statement as such.

Commercial General Liability Insurance: to include an aviation endorsement of not less than \$1,000,000 bodily injury and property damage per accident or occurrence.

Commercial Automobile Liability Insurance: covering all vehicles used by the Contractor in the performance of services under this agreement with combined single limits not less than \$1,000,000 bodily injury and property damage per accident or occurrence. If the contractor will not utilize any vehicles personal or contractor owned vehicles in the performance of their contract responsibilities, then the contractor shall provide a written statement as such.

Personal Automobile Liability Insurance: The Contractor shall provide a copy of personal automobile liability with minimum coverage limits of \$300,000 combined single limit per occurrence. If the Contractor will not utilize personal automobiles or travels to and from work on a snow mobile, ATV, bicycle or walks, then the Contractor shall provide a written statement as such.

The Department of Transportation and Public Facilities shall be named as an additional insured for all automobile liability coverages. All of the above insurance coverages shall be considered to be primary and non-contributory to any other insurance carried by the State of Alaska, whether through self-insurance or otherwise. In addition to providing the above coverage, the Contractor shall, in any contract or agreement with subcontractors performing work, require that all indemnities and waivers of subrogation it obtains, and that any stipulation to be named as an additional insured it obtains, also be extended to waive rights of subrogation against the State of Alaska and to add the State of Alaska as additional named indemnitee and as additional insured.

Evidence of Contractor's ability to obtain insurance shall be furnished to the Department prior to award. Evidence of Insurance shall be furnished to the Department prior to issuance of a Notice to Proceed. Such evidence, executed by the carrier's Representative and issued to the Department, shall consist of a certificate of insurance or the policy declaration page with required endorsements attached thereto which denote the type, amount, class of operations covered, effective (and retroactive) dates, and dates of expiration. Acceptance by the Department of deficient evidence does not constitute a waiver of contract requirements.

When a certificate of insurance is furnished, it shall contain the following statement:

"This is to certify that the policies described herein comply with all aspects of the insurance requirements of the Ekwok Airport, Ekwok AK 99580."

(XV) BUSINESS LICENSE REQUIREMENT

Prior to award of the contract the low bidder must show evidence of holding a valid Alaska business license and any necessary applicable professional licenses required by Alaska Statute. Bids must be submitted under the name as appearing on the person's current Alaska business license in order to be considered responsive. Offerors should contact the Department of Commerce, Community and Economic Development, Division of Corporations, Business, and Professional Licensing, P. O. Box 110806, Juneau, Alaska 99811-0806, for information on these licenses. Acceptable evidence of an Alaska Business License is:

- Canceled check for the business license fee;
- Copy of the business license application with a receipt date stamp from the State of Alaska business license office;
- Receipt form the State of Alaska business license office for the license fee;
- Copy of the bidder's valid business license;
- Sworn notarized affidavit that the bidder has applied and paid for a business license.

(XVI) TERMINATION

- C. The Department may terminate the contract by giving seven (7) days' notice to the Contractor if:
- (1.) The Contractor fails to comply with the terms of this contract. In this event, the Contractor shall forfeit the performance bond, if required.
 - (2.) The Contractor fails to begin work under this contract within the time specified in the contract documents.
 - (3.) The Contractor fails to conduct and record the on-site inspections as defined in this contract.
 - (4.) The Contractor performs this work in an unsuitable manner or discontinues the prosecution of said work as defined in this contract.
 - (5.) The Contractor performs this work in an unsafe manner placing any parties involved in this contract at risk.
 - (6.) The Contractor makes an assignment for the benefit of creditors without the consent of the Procurement Officer.
 - (7.) The Contractor fails to attend training courses as directed by the Department unless specifically excused by the Department Representative.
 - (8.) The Contractor disregards Regulatory Requirement of any public body having jurisdiction at Airport location.
 - (9.) The Contractor allows any assessed final judgment to stand unsatisfied for a period of 60 days.
 - (10.) The contractor utilizes any State furnished equipment, materials, facilities and etc. for any reason other than for the sole purposes of performing this contract in accordance with the contract work areas above.
- D. The Department may terminate this contract in writing by providing seven (7) days notice, at any given time, if the funding for the contract, as allocated by the Alaska Legislature, is insufficient for continuation of the contract. **This Contract is contingent upon funding of the Department's Operating Budget.**
- E. The Contractor will forfeit the performance bond, **if required**, if the Contractor ceases providing the services required in accord with the terms of this contract, unless the Contractor has provided the Department with a written thirty (30) days termination notice and continued to perform the required services during the thirty (30) day period.
- F. The Department may terminate the contract in whole or in part for the convenience of the Department.
- G. If there is any damage, waste, theft and etc. by the Contractor or knowingly allows such activities, the contract may be immediately terminated by the Department. Examples are, but not limited to, damage beyond normal wear and tear to any equipment, structure or infrastructure, unauthorized consumption/use of any utility such as electricity or fuel, any type of damage of navigational aids and lights, and etc.

(XVII) PAYMENTS

- H.** If a Contractor uses a subcontractor or employee to perform the work or a portion of the work required under this contract, the subcontractor or employee must receive payment from the Contractor at least monthly. In the event the Contractor fails to pay the subcontractor or employee within seven days following receipt of the quarterly payment from the Department, the Department reserves the right to withhold any payment from the Contractor until such time the subcontractor or employee is paid.
- I.** The Department reserves the right to withhold payment for contractual services of the Contractor and/or all subcontractors or employees who fail to attend all required training.
- J.** Payments to the Contractor by the Department for services provided under the terms of this contract will be based on quarterly statements submitted by the Contractor to the Department Representative. The statement will be due no later than the tenth (10) calendar day of each month following the close of the quarter. Quarter's end September 30, December 31, March 31 and June 30.
- K.** Hour meter reading, equipment/license number and type of equipment for each piece of equipment shall be included with each quarterly statement. The spaces for fuel used and estimated fuel remaining shall be completed on each quarterly statement. Payment will not be processed without this information.
- L.** The Department reserves the right to withhold payment of contractual services from the Contractor and/or all subcontractors or employees who perform any unauthorized alterations to State property or equipment in order to pay for repairs to reinstate to the original condition.
- M.** The annual prices bid by the Contractor referenced on the Proposal shall be inclusive of one full 12 month State of Alaska Fiscal Year period. Any contract duration which does not contain 12 full months of the State of Alaska's Fiscal Year shall be prorated beginning the Date of Award and paid accordingly with this contract and technical specifications.
- N. Direct Deposit:** If the Contractor has not previously established direct deposit for payments with the State of Alaska, the Contractor's shall complete the Electronic Payment Agreement, currently located at http://doa.alaska.gov/dof/forms/resource/EDI_agreement.pdf and either mail or fax the completed form to the address or fax number as indicated.
- or
- VENDOR SELF SERVICE (VSS):** If you haven't already done so; click the Below Link to Setup Your Iris Account Through Vendor Self Service (VSS). <HTTP://DOA.ALASKA.GOV/DOF/IRIS/VENDOR.HTML> (For Processing Payments Electronically)
- O.** Payment will be made in accordance with AS 37.05.285 (a)(2). 30 days after receipt of a proper billing for the amount of the payment due, if a date on which payment is due is not established by contract and if the billing contains or is accompanied by documents required by the contract or purchase order
- P.** If the contractor has not previously established a vendor number with the State of Alaska, the Contractor shall complete the Request for Taxpayer ID# and Information; Substitute Form W-9 currently located at http://doa.alaska.gov/dof/forms/resource/sub_form_w9.pdf and fax the completed form to (907) 269-0831 before payment can be processed. Delay in submitting the form will delay payment until the form has been completed.
- Q.** Consumer Price Index (CPI): Contract prices for service will remain firm through **May 7, 2024**.

(XVIII) CONTRACTOR RESPONSIBILITIES

R. WORK OUTLINE: The Contractor shall be responsible for the services described below unless the Department representative modifies the scope of work through written direction.

The Contractor shall make a reasonable attempt to contact the Airport Manager at least once weekly to report current conditions and status. This may be done via email, telephone or fax.

S. DAILY INSPECTION SERVICES: The Contractor shall conduct daily inspections of the airport. The Contractor shall keep a written list noting items that need repair, cleaning, or replacement. The list will be used for reference when the Contractor performs maintenance in accord with the terms of this contract. It should also be used as a reference when the Contractor notifies the Department representative of problems or conditions beyond the Contractor's capability to control. The Contractor shall conduct daily inspections of the airport and roadway(s) and note the following on a written list.

1. Operation of lighting systems and/or reflective cones, broken or burned out or missing equipment. If four or more lights total are inoperative and cannot be replaced and/or repaired, the Contractor will notify the Department representative in order to enable the representative to issue a Notice to Airmen (NOTAM) to the appropriate Automated Flight Service Station (AFSS) placing the airport lighting system out of service.
2. General condition of the runway surface, parking apron, taxiway, roads, segmented circle, wind cone(s), threshold markers, and drainage. During the inspection, particular emphasis should be given to potholes, ruts, large rocks, lighting, rotating beacon and the debris on or near these areas and/or structures. All deficiencies shall be repaired and/or removed as required.
3. Contractor must be familiar with the location of all usable aircraft tie downs provided by the State. This will allow the Contractor to make these tie downs available for a reasonably coordinated request.
4. The Contractor shall report discrepancies requiring state maintenance support to the Department representative as soon as possible.

T. TRASH REMOVAL: Once each month or as needed, the Contractor shall collect and remove all trash/debris from the airport and roadway property (only that property not under the control of a lessee (tenant)) and dump it at the nearest local sanitary landfill approved for disposal of garbage. The Contractor shall not allow trash to accumulate on State property or in State owned facilities and buildings. The Contractor shall participate with any type of local community recycling program and dispose of materials accordingly.

U. TOOLS AND MISCELLANEOUS SUPPLIES: The Contractor shall be responsible for furnishing and maintaining all hand tools and related safety equipment necessary for performance of this contract. The Contractor shall also furnish the following supplies: hand cleaner, paper towels, plastic liners for trash and any other minor supply items necessary for day to day compliance with this contract. The Department shall furnish supply items and tools listed within Section (XIV) C. All items that are the responsibility of the Contractor shall be included in the overall contract cost.

V. SUPPLY AND EQUIPMENT STORAGE: Department-owned storage space may be available for storage of Department-owned equipment, materials, and supplies used in the performance of this contract only. Items other than those owned by the Department shall not be stored Department Building without **written** consent of the Department Representative. The Contractor shall maintain all buildingspaces in a neat and orderly manner at all times

All State owned equipment shall be kept inside of the Snow Removal Equipment Building (SREB) at all times when not in use; no other equipment shall be permitted or allowed inside the SREB without written consent from the Department representative. Prior to parking inside the SREB, all equipment shall be cleared of excess snow and debris.

If the airport has a heated equipment storage building or SREB, the contractor shall conserve heating fuel in the heating fuel storage tanks. To conserve energy and fuel, thermostat settings shall be kept between

40 and 50 degrees to keep the equipment at operating condition level. The Department shall fill the fuel storage tanks with the required heating fuel. This will normally be accomplished at the beginning of each contract year unless otherwise specified by the Airport Manager. If the Contractor requires additional fuel, the Contractor shall notify the Airport Manager. The Contractor shall maintain the storage space in a neat and orderly manner at all times. If equipment is not in use for extended periods, heaters shall be turned off to conserve heating fuel. If the SREB is equipped with a thermostat and a timer relay, the Contractor shall not alter the thermostat, timer or circuit in any way without prior written approval from the Airport Manager.

The Contractor shall not use any electrical heating devices for heating the interior of the SREB. The use of portable electric heaters consumes valuable resources and could result in a fire. The Department will hold the Contractor responsible for any excess electrical costs related to the use of electric heating and may deduct these costs from any payments due the Contractor.

The Contractor shall not use the electrical equipment room for storage. Storage of equipment, supplies, tools and etc. inside the electrical equipment room is prohibited.

W. NOTICE TO AND RELATIONS WITH THE PUBLIC: The Contractor shall post in a readily visible and conspicuous location, outside of the airport maintenance facility or at the local Post Office, the name of the individual representing the Contractor. This notice shall include telephone number(s), and/or physical location(s) where the representative may be contacted for the reporting of complaints or requests for information. This notice shall be maintained during the term of the contract.

The Contractor, subcontractors, and all employees shall conduct themselves in a professional manner during the performance of their contract duties.

X. Maintenance Functions:

G1. The Contractor will provide assistance to State employees dispatched to the airport for maintenance. The support will include but is not limited to:

- (a) Assist with troubleshooting problems prior to and upon arrival.
- (b) Assist state employees with local arrangements and equipment as necessary to perform maintenance work.

G2. The Contractor will perform minor building maintenance as necessary to ensure the safety and operation of the building and State property. The minor maintenance may include but is not limited to:

- (a) Overhead/Bi-fold door adjustments;
- (b) Personnel door adjustment;
- (c) Furnace filter replacement;
- (d) Change light bulbs;
- (e) Replacement of door weather-stripping;
- (f) Fuel system inspections including tank sticking and water detecting

The Contractor shall provide the following:

(1) **FALL AND WINTER MAINTENANCE**

(a) **Airport:**

- (i) The Contractor shall begin snow control efforts at a time no later than when two (2) inches of snow or one half (1/2) inch of slush have accumulated on runway, taxiway or apron surfaces. In all cases, the Contractor shall begin snow removal efforts with sufficient time to

allow completion of normal snow removal on the runway, taxiway and apron surfaces before the first scheduled air carrier flight departure or arrival. Snow drifts and berms will not be allowed to develop on the airport's aircraft movement areas (inside the edge lights or cones) unless the storm is so severe that reasonable efforts to remove snow are not possible, at which time, snow removal operations may cease until the storm subsides to the point where snow removal efforts are possible. If such a condition develops, the Contractor will immediately contact the Department representative.

Note: The Department representative may require the Contractor to issue **NOTAMS** directly to the FAA's Flight Service Station (FSS), under certain circumstances.

(ii) Runway(s) and taxiway(s) shall be plowed free of loose snow full width and length. Snow must be plowed to the outside of the Runway Safety Area (RSA). All berms and piles shall be tapered (leveled) off to the outside edges of the RSA(s). Snow banks will be placed off the sides of the runway and not on the threshold/ends of the runway(s). The Contractor shall not remove the first ½" of snow in order to allow a snow pack to develop on the aircraft movement surfaces.

(iii) Apron(s) will be plowed free of loose snow. Snow control on apron(s) will begin after the runway(s) and taxiway(s) have been plowed.

(iv) Once runway, taxiway and apron snow control has begun, snow **and** ice will be removed to the greatest extent reasonably possible. If ice cannot be removed or scarified enough to provide a reasonably safe surface for aircraft, the Contractor shall immediately notify the Department representative.

(v) Loose snow must be removed from around the threshold markers, segmented circle, wind cones, runway lights, precision approach path indicators (PAPI), visual approach slope indicators (VASI) and/or reflectors using caution to avoid damaging or destroying these fixtures. Snow/frost will be cleaned from lights, signs, segmented circle panels, and threshold markers daily as necessary. Snow may need to be removed by hand in these areas if there is any possibility of mechanical damage to the items above. Snow and ice will be cleared from areas around the PAPIs and VASIs as not to block the signal.

(vi) After snow control efforts are completed, all equipment will be returned to the SREB. For airports that are not equipped with a SREB, the equipment shall be moved clear of areas where equipment will not create a hazard to operating aircraft.

(vii) When present, slush shall be removed from the runway unless the surface is soft enough for the equipment to cause rutting. Prior to spring break up or periods of heavy rain; runway, taxiway and apron shoulders, and adjacent ditches will be cleared to assist drainage.

(viii) The December 18, 2000, "Airport Marking Standards for Unpaved Airports" is included as Attachment "A" to this contract. The Contractor shall assure all cone markers, visibility enhancers and etc. are positioned on the airport in accordance with these standards.

(ix) Airport Visual Aids shall be maintained in good working order. These include wind cones and poles, segmented circles, lighting systems, obstruction lights, rotating beacons, beacon towers, PAPIs and VASIs.

(b) **Roadways:**

(i) Snow plowing operations will begin on roads only after airport snow control efforts have been completed.

Snow control on roads need not begin until **four (4) inches** of loose snow has accumulated on the surface. Once roadway snow control has begun, snow and ice will be removed to the greatest extent reasonably possible.

(ii) Prior to spring break up and periods of heavy rain, road shoulders and ditches will be graded and any debris removed to assist drainage.

(iii) If provided by the Department, culvert thaw wires will be activated by the Contractor when surface ice appears in drainage ditches and be de-activated by the Contractor when spring thaw has begun. The Contractor will notify the Department representative before activating or de-activating any thaw wires.

(iv) Roads should be passable, provide adequate traction and remain free of berms or other hazards.

(2) **SPRING AND SUMMER MAINTENANCE**

(a) **Airport:**

(i) All areas on the airport where aircraft operate, except private leasehold property, will be maintained clear of rocks two (2) inches or more in diameter and any foreign objects. These areas will be maintained free of holes or depressions that exceed three (3) inches in depth and/or five (5) inches in diameter that may affect directional control of an aircraft. Should potholes, ruts, etc. develop, they will be smoothed out as soon as possible. Aircraft Movement Area Surfaces shall be graded, free of rutting and potholes.

(ii) Once each summer, or as determined by the Department representative, all brush and weeds will be cut and removed from around the runway, taxiway(s), and apron(s) to ground level. The Contractor shall conduct minor brush cutting within the runway safety area and taxiway safety area as defined in the Airport Layout Plan. Example of this area is thirty (30) feet beyond the edges of the runway and two hundred and forty (240) feet beyond the thresholds/ends, unless these dimensions encroach upon other than airport property, in which case, cutting will terminate at the property line.

(iii) Once during the spring and once during the fall, the Contractor will assist the Department representative with full length and width grading of gravel surfaces. This shall be done to maintain smooth and consistently level surfaces in aircraft maneuvering areas.

(iv) Movement Area Surfaces shall be free of rutting and potholes. Should potholes, ruts, or similar surface features develop, they shall be backfilled and compacted with similar or like kind runway surface material.

(v) The Contractor shall exercise a proactive vegetation management program and shall include clearing brush and vegetation away from the SREB, aircraft movement area lighting systems, segmented circle, wind cone(s), threshold markers and any other Airport Visual Aids

on airport property.

(b) **Drainage Ditches - Culverts:**

All drainage ditches and culverts will be cleared of any debris that might obstruct drainage. The Contractor will notify the Department representative if during routine inspection, a collapsed, blocked or otherwise obstructed culvert is discovered which is beyond the Contractor's ability to repair.

(c) **Roads:**

(i) Roadways will be maintained in a smoothly graded state over the entire width of the existing road surface. Roadways shall be sloped from the center to each side in order to allow water to drain from the road.

(ii) The roadway surface will be kept free of rocks three (3) inches or more in diameter.

(iii) As required, all brush or trees must be maintained cut to ground level for a minimum distance of eight (8) feet from the edge of the traveled roadway surface.

(iv) Equipment shall not be driven outside the road limits allowed in this section for clearing purposes without proper coordination with the Department representative for permitting purposes.

(d) **Signs, Lights, Markers, & Reflectors:**

The Department is responsible for the initial placement of wind cones, threshold markers, runway lights, segmented circle, reflectors, and signs. The Contractor will be responsible for replacing any damaged, missing, or burnt out items of this type in accordance with Item P-660 and Attachment A. Light lens MUST be replaced with the same color and style as the original.

The Contractor will request from the Department representative any materials necessary to repair or replace these items. The Department will provide these materials unless the damage is due to negligence on part of the Contractor. In event these items are damaged by the Contractor negligence, the Contractor will replace these items at his sole expense.

During the Contractor's daily inspections, repair or replace any of these items and mark all items on the inspection list.

Y. Maintenance of State Equipment:

Only persons authorized by the Department representative shall operate State furnished equipment. The Contractor shall assure all State furnished equipment is used only for airport and airport access road maintenance associated with this contract. Maintenance of DOT&PF rural airport equipment is coordinated by the State Equipment Fleet (SEF). Contractor should have the contact information for the local SEF technician and make contact info available to all operators. The Contractor will comply with the following:

- (1) Contractor shall assure a proper walkaround inspection of the equipment shall be performed prior to operating equipment. A checklist shall be provided by the Department representative

and completed for daily walkaround inspections. Any deficiencies should be reported as soon as possible to the Department representative.

- (2) Check coolant, hydraulic system, battery, air filter gauge, DEF and oil levels before starting equipment to be certain that all are in the recommended operating range.
- (3) The equipment will be greased a minimum of once per week when being used. Fluid reservoirs that can be checked via dipstick, site-glass, or cap removable by hand should be checked for proper levels. Contractor should not check fluid levels of sealed components with fill/drain plugs. Any time oil or fluids are changed, used oil and oil filters shall be stored in suitable leak-proof containers and labeled as “Used Oil” within the equipment storage building. No material shall be dumped within or outside the building. The Department will be responsible for disposal of these materials.
- (4) All crawler tractor (dozer) frames (swing frames), must be cleaned of all debris after each use.
- (5) Cutting edges will be changed whenever they are worn to within one (1) inch of the moldboard.
- (6) The fan belt and alternator belt should be tight for proper cooling and battery charging. Should the batteries become discharged, the Contractor will protect and store them from freezing. The batteries should be in suitable storage in temperatures higher than 32°F and avoid cracking the internals and case.
- (7) The Contractor shall ensure equipment is properly winterized before freezing weather begins. This is typically performed by SEF technicians. The Contractor should contact SEF if unsure if equipment is winterized. Equipment must be filled with an antifreeze mixture that assures protection to at least minus 50 degrees Fahrenheit. At this time, a check of the radiator and all hoses for leaks and loose hose clamps should be made. Used antifreeze shall be collected and stored in suitable leak-proof containers and labeled as “Used Antifreeze”. No waste material shall be dumped within or outside the building. Inspect and test cranking and charging systems and all accessory heaters.
- (8) All vertical exhaust pipes (stacks) must be protected with rain caps or kept covered when the equipment is not being operated. The Contractor will contact Department representative or SEF for repair.
- (9) If there are any problems with Department owned equipment that the Contractor is unable to repair, the Contractor will advise the Department representative immediately. For example: If the cutting edges of a blade are worn, after notification, replacement edges will be sent to the Contractor who will replace the worn edges. If the Contractor is unable, for any reason, to perform work of this type the Department representative should be notified.
- (10) The Contractor shall provide all hand tools for performing routine operator required equipment maintenance on Department supplied equipment. Department crews with appropriate tools will be sent to the site to accomplish maintenance and repairs.
- (11) The Department shall furnish all necessary fuel, Diesel Exhaust Fluid (DEF), oil, other lubricants, antifreeze and associated filters for use on all Department supplied equipment. The Contractor is responsible for these items when Contractor furnished equipment is required and/or used in accord with the terms of this contract.

- a. Contractor shall be aware of equipment needing Diesel Particulate Filter Regeneration procedures, DEF, and its proper use and storage. This pertains primarily to equipment model years 2014 and newer, but could exist on equipment as old as 2010. Contact your SEF technician for proper regen procedures. DEF level should be checked and filled as needed before operation.
 - b. Equipment fuel reimbursement shall only be authorized if pre-approved by the Airport Manager and in the event State supplied fuel does not fulfill the requirements in order to perform contract duties.
 - i. Fuel invoices/receipts shall be submitted to the Airport Manager for approval. Fuel invoices/receipts shall include Contractor's printed name, equipment number and hour meter reading. If required by the Maintenance District, obtain a purchase order number and record it on the invoice/receipt.
 - ii. The Contractor shall explain the correlation between how many hours worked on the contract and the amount of fuel purchased for each invoice/receipt.
 - iii. The Airport Manager will then evaluate the request and process for payment if appropriate.
 - iv. All requests for equipment fuel reimbursement must be received by the Airport Manager within 30 days of the date on the equipment fuel receipt.
- (12) Equipment shall not be operated in temperatures colder than -30° Fahrenheit unless an emergency condition necessitates. The Contractor shall immediately notify the Department representative.
- (13) Equipment should be started and attain proper running temperature prior to use. Once in operation, the Contractor shall not allow equipment to idle for more than one minute in temperatures greater than 20°F and 10 minutes with temperatures less than 20°F in winter. Equipment shall not be allowed to idle in warm weather. This is inclusive of spring, summer and fall (P&P 02.01.110).
- (14) The Contractor shall inspect equipment after each use to determine whether maintenance or repair is necessary. If maintenance or repair is necessary, the Contractor shall report the issues to the Department representative and/or SEF representative.

- Z. Runway Conditions and Closure Procedures:** Before beginning snow removal, the Contractor shall contact the Department representative or AFSS to issue a NOTAM. When the work is completed, the NOTAM shall be canceled by contacting the Department representative or the AFSS.

Before entering the runway, the Contractor shall make a "blind" radio transmission on the appropriate Common Traffic Advisory Frequency (CTAF) to announce his intentions. For example: "Ekwok Traffic, State Maintenance Grader entering runway 3/21 for snow removal. All traffic please advise." After completing his work operation on the runway, he will make a subsequent "blind" notice of his departure. While on the runway, the Contractor shall announce the "blind" notice any time traffic is heard on the radio.

If at any time the Contractor determines the runway is unsafe for use by aircraft, he shall immediately contact the Department representative or AFSS by the quickest means possible to inform them of the unsafe condition(s).

If it is necessary to close the runway due to unsafe conditions, climatic conditions, or work in progress, the Contractor is to contact the Department representative or AFSS.

AA. Accident at the Airport: If there is an aircraft accident, vehicular accident, any other accident or incident on the airport, the Contractor shall notify the Department representative immediately.

- (1) In the event a major accident occurs where serious injuries, or fatalities are involved, the Contractor will attempt to rope off the immediate area of the accident in an effort to keep unauthorized persons away. The Contractor will attempt to prevent persons from entering the accident area, except for law enforcement officers, local rescue and medical personnel, National Transportation and Safety Board (NTSB) representatives, State Division of Risk Management, and DOT&PF representatives.
- (2) The Contractor shall provide as much information as possible to the Department representative concerning the accident. It is imperative that the weather and runway conditions be noted at the time of the accident. Photographs shall be taken of the aircraft accident, the surrounding area, and any scattered pieces of wreckage. Pictures shall be taken from eight (8) different directions, to provide a perspective of the accident from all viewpoints.

The Department representative will assist the Contractor in completing any DOT&PF furnished accident report forms.

BB. Storing and Ordering Supplies: The Contractor is responsible for assuring all supplies and parts are stored properly labeled and stocked in a safe and practical manner. This includes new and used fuels, oils and lubricants, and replacement parts. The Contractor shall notify the Department representative when parts and supplies are required, in a manner to assure timely procurement and delivery.

K1. If a spill of any petroleum products including oils, fuels, lubricants, or solvents occurs on State property, the Contractor is responsible for assessing and containment of the spill and immediately notifying the Alaska Department of Environmental Conservation at (907) 269-3063 in Anchorage during normal business hours and (800) 478-9300 outside normal business hours in accordance with *AS 46.03.755 and 18 AAC 75 Article 3* and the Alaska Department of Transportation representative. The Contractor shall cordon off any spill site, photograph the area, and prepare a written statement of the event as soon after the event as practicable. The Contractor shall complete the Alaska Department of Environmental Conservation Oil & Hazardous Substances Spill Notification Form located at <https://dec.alaska.gov/spar/ppr/spill-information/reporting/> and fax to (907) 269-7648 and to the Alaska Department of Transportation representative.

In the event the Contractor, Contractor's Representative, subcontractors, or any employee causes a spill of fuel or other contaminates, the Contractor is responsible for reporting, containing, and cleanup of the spill. When failure to take proper care or coordination (negligence), all costs associated with the cleanup of the spill, and any remediation that results from the spill shall be at no additional cost to the Department.

L Electricity:

Where Department furnished electricity is not available, the Contractor will be responsible for providing electrical power for pre-heating State equipment during winter months. The Contractor would supply a power source with a minimum of 2,000 watts/120 volts to plug in and pre-heat each piece of equipment. Typical plug in devices are transmission pad heater, oil pan heater, block (coolant) heater, battery charger (maintainer).

The Contractor shall be responsible for the judicious use of electricity whether it is Department or Contractor furnished at the airport SREB(s). Lights will remain off outside of the standard operating times for the airport unless there is an emergency.

M Vandalism:

The Contractor will, to the best of its ability, protect any State assigned equipment, building or any other asset from damage or vandalism and promptly inform the Department representative and local law enforcement of any such occurrence.

N Traffic Flow:

The Contractor will perform the required services to assure a minimum amount of interference with aircraft or vehicle operations.

O Use of Station Materials:

The Contractor will be responsible for the judicious use of State supplied materials, supplies and parts shipped to the station.

P Other Employment:

The Contractor, if an individual, shall perform this work as an independent Contractor. If the independent Contractor has other employment, they shall submit in writing that this other employment shall not interfere and/or distract from performing work on this contract.

Q Taxes:

The Contractor shall pay any federal, state, or local taxes incurred by it during performance of this contract.

R Assignment of Contract Responsibilities:

The Contractor shall not subcontract this contract without the prior approval of the Department representative. The Contractor shall be responsible for all aspects of this contract. Subcontractors shall be identified by the contractor in accordance with the Standard Specifications for Airport Construction, Section 80, Prosecution and Progress at <http://www.dot.state.ak.us/stwddes/dcsspecs/assets/pdf/aptspecs/airportspecs.pdf> and Alaska Statute 36.30.115.

The Contractor shall submit a Contractor Self Certification for Subcontractors and Lower Tier Subcontractors, Form 25D-042, before the Contractor or any subcontractor subcontracts, sells, transfers, assigns, or otherwise disposes of the Contract or any portion of the Contract. The Department has authority to review subcontracts and to deny permission to subcontract work. The Department may penalize the Contractor for false statements or omissions made in connection with Form 25D-042.

S Other Equipment Used or Leased by Contractor:

Unless authorized in advance by the Department, if the Contractor leases any equipment from third parties for the performance of this contract, the Contractor will be solely responsible for reimbursement of any expense or liability associated with the rental agreement.

T Work performed by the Contractor Beyond Scope of Contract:

Any additional services performed by the Contractor, which require additional compensation, must be approved in writing by the Department, and signed by the Department representative prior to commencement of any work.

U Training

The Contractor, any approved subcontractor, or approved employee shall be responsible for attending all Airport training when notified of such training by the Department representative. When training occurs away from the airport, all travel expenses will be paid by the Department.

V State Assets

It shall be the Contractor's responsibility to protect all State assets. The Contractor shall ensure all assets are secure when unattended or not in use.

(XIV) DEPARTMENT RESPONSIBILITIES:**A Department Representative:**

The Department will assign a representative who will be available, during reasonable time periods, in order to provide coordination and direction to the Contractor concerning matters related to the terms and conditions of this contract.

B NOTAMs:

Notice to Airmen (NOTAM), are advisory messages distributed to airport users by the FAA regarding airport conditions that may be hazardous. NOTAMs must be issued by the airport operator. When advised by the Contractor of hazardous conditions, the Department representative will endeavor to issue a NOTAM describing the condition. However, due to the remote nature of the Airport, lack of continual monitoring and unreliable communication facilities, it is often difficult to assure that NOTAMs are published for all conditions. Therefore, the Department will assure that a notice is continually published within the "Chart Supplement Alaska" which advises pilots to use caution when operating into the airport due to the frequent lack of surveillance for airport hazards. Pilots will also be advised to provide their own airport condition inspections before operating at the airport.

NOTE: The Department representative may require the Contractor to issue NOTAMs directly to the FAA Flight Service Station (FSS), under certain circumstances.

C State Provided Materials:

Unless otherwise required to be supplied by the Contractor under Section (XVII) D "Contractor Responsibilities," the Department will provide all parts, materials, and items needed for the Contractor's use when performing work under the terms of this contract. This includes all necessary fuel, oil, other lubricants, antifreeze and associated filters for use on all State supplied equipment.

D Storage:

If available, State owned storage space may be made available to the Contractor for storage of equipment, materials, and supplies used in the performance of this contract.

E Work beyond the Contractor's Capabilities:

The Department will be responsible for repair and maintenance of items beyond the Contractor's scope of ability as specified under "Contractor Responsibilities."

F Accident Reporting:

The Department representative will assist the Contractor in completing any State furnished Accident Report Form, if an accident should occur on the Airport.

G Non-Routine Maintenance on Heavy Equipment:

During non-routine maintenance, such as an engine replacement, Department crews with appropriate tools will be sent to the site to accomplish the work. The Contractor shall provide tools for performing routine equipment maintenance on State supplied equipment.

H Adding or Substituting Items of Heavy Equipment:

During the term of this contract, the Department may add, delete, or substitute State owned equipment as it deems necessary to be in the Department's best interests. However, all such changes will be reasonable and not add to the Contractor's maintenance burden.

(XIX) DEFINITIONS

As used in this contract the following terms are defined as follows:

ADDENDA. Clarifications, corrections, or changes to the plans, specifications or other contract documents issued graphically or in writing by the Department after the advertisement but prior to the opening of proposals.

ADVERTISEMENT. The public announcement, as required by law, inviting bids for work to be performed or materials to be furnished.

AIRCRAFT MOVEMENT AREA. Runways, taxiways, and other areas of an airport that are used for taxiing, takeoff, and landing of aircraft, exclusive of loading ramps and aircraft parking areas.

CONTRACT AWARD. The acceptance, by the Department, of the successful bid. The award is effective upon execution of the contract by the Procurement Officer.

BIDDER. An individual, firm, corporation or any acceptable combination thereof, or joint venture submitting a bid for the advertised work.

AMENDMENT. A written order by the Department covering changes to the contract, within its general scope, and establishing the basis of payment and time adjustment, if any, for the work affected.

CONTRACT. The written agreement between the Department and the Contractor setting forth the obligations of the parties for the performance of the work. The contract includes the Invitation For Bids, Instructions to Bidders, Proposal, Maintenance Contract Form, Technical Specifications, and any Special Provisions, Drawings, Plans, Addenda, any change orders, directives or supplemental agreements that are required to complete the work in an acceptable manner, all of which constitute one instrument.

PROCUREMENT OFFICER. The person authorized by the Commissioner to enter into and administer the contract on behalf of the Department. He has authority to make findings, determinations and decisions with respect to the contract and, when necessary, to modify or terminate the contract.

CONTRACTOR. The individual, partnership, firm, corporation, or any acceptable combination thereof, contracting with the Department for performance of prescribed work.

DEPARTMENT. The Alaska Department of Transportation and Public Facilities and its agents, officers, and employees.

DOT&PF. Alaska Department of Transportation & Public Facilities.

EXTRA WORK. An item of work not provided for in the contract as awarded but found essential by the Procurement Officer for the satisfactory completion of the contract within its intended scope.

FSS. Federal Aviation Administration Flight Service Station

REQUEST FOR QUOTES (RFQ). The advertisement for proposals for all work or materials on which bids are required.

NOTAM. Notice to Airmen

NOTICE OF AWARD. The written notice by the Department announcing the apparent successful Bidder and establishing the Department's intent to award the Contract when all required conditions are met.

PROPOSAL. The offer of a bidder, on the prescribed forms, to perform the work at the price quoted.

SREB. Snow Removal Equipment Building

SPECIFICATIONS. A general term applied to all directions, provisions and requirements pertaining to performance of the work.

STATE. The State of Alaska acting through its authorized representatives, agents, officers, and employees.

SUBCONTRACTOR. An individual, partnership, firm, corporation or any acceptable combination thereof to which the Contractor sublets part of the contract.

SUBLET. The act of the Contractor entering into a contract with a subcontractor for the purpose of having the subcontractor perform the work or a portion of the work.

WORK. Work is the act of, and the result of, performing services, furnishing labor, furnishing equipment, furnishing supplies, and incorporating materials into the runway as required by the contract, and performing all other duties and obligations required by the contract.

(XX) ATTACHMENTS

Attachment A – Airport Marking Standards for Unpaved Airports

Attachment B – None

Attachment C – Lighting / Visual Aids

Attachment A

AIRPORT MARKING STANDARDS FOR UNPAVED AIRPORTS

December 18, 2000

The following standards for runway markers will be used by Department of Transportation and Public Facilities (DOT&PF) staff in the design, construction, and maintenance of unpaved airports. These standards will be implemented when designing new airport improvement projects and maintaining all existing DOT&PF unpaved airports, as adequate funding allows. Ultimately, all DOT&PF unpaved airports will be marked according to standards described below and shown in Figures 660-1 through 660-4. These standards have been reviewed and found acceptable by the FAA and supersede previous standards dated October 9, 1986. The standards begin with definitions of runway and runway safety area because the placement of markers depends on the designation of the boundaries of these areas.

Runway: A defined rectangular maneuvering area on an airport prepared and maintained for the landing or takeoff operations of aircraft. The runway is the only portion of an airport that should be used for aircraft landings and takeoffs. The runway is distinct and should be distinguished from other surfaces such as taxiways or safety areas and maintained accordingly. The dimensions of a runway are defined in the Airport Layout Plan (ALP) or, where an ALP does not exist, is outdated or is in incorrect, the dimensions should be determined after consultation with the FAA. After a runway's length and width are established, these dimensions must be published in the Airport/Facility Directory (Supplement Alaska) and the Airport Master Record (Form 5010). Subsequent changes to the runway length or width also must be promptly noted in these publications. Guideline criteria used for determining runway dimensions on the different classes of airports may be found in FAA Advisory Circular No. 150/5300-13.

Runway Safety Area: Defined as a surface surrounding the runway that has been prepared for reducing the risk of damage to airplanes in the event of an undershoot, overshoot or excursion from the runway. A rectangular area centered on the runway centerline which includes the runway (and stop way, if present) and runway shoulders. Safety areas are not intended for normal aircraft operations but enhance the safety for airplanes that undershoot, overrun, or veer off the runway. It provides accessibility for fire fighting and rescue equipment during such incidents. The safety area is cleared, drained, graded, may be turfed and must not have any potentially hazardous ruts, depressions, humps or other surface variations. Safety areas are designed and maintained to support the movement of any aircraft allowed to use the airport without causing substantial damage. If a safety area cannot be maintained to this standard, the unusual and hazardous condition must be NOTAM'd or the dimensions of the safety area must be reduced to include only the area that can be maintained free of conditions that might cause substantial damage to an aircraft. On airports that provide snow removal services, the FAA regulations and advisory circulars require that snow be removed from safety areas only to the extent that aircraft on the runway does not make contact with snow banks. However, it is advisable to maintain the safety areas off the thresholds clear of significantly large snow banks and assure that all lights or markers are visible.

Guideline criteria used for determining safety area dimensions on the different classes of airports may be found in FAA Advisory Circular No. 150/5300-13. As is often the case in Alaska, it sometimes is impractical to construct an airport in accordance with these particular standards. In those instances, the FAA will work with airport operators on a case-by-case basis in order to establish alternative dimensions.

Runway Threshold Marking

Unlighted Runways

Threshold cone markers. On unlighted runways, use reflective cone markers to mark the runway threshold. Place three (3) cone markers on each side of a threshold, for a total of six (6) markers on each end (figure 660-1). Place the markers in a line perpendicular to the extended runway centerline and between 2 feet and 10 feet from the designated runway threshold. Place the innermost threshold cone marker in line with the runway edge markers. Space the remaining threshold cone markers evenly at 10-foot intervals outbound from the runway (figure 660-1). Use markers that do not exceed 30 inches in height. Use reflective cone markers with 180-degree green and 180-degree red reflective bands. Position the markers so that only the red color is visible from the runway side, and only green is visible from the approach path. Use a reflective band made of high intensity sheeting of sufficient width to meet FAA specifications for reflective markers (AC 150/5345-39D for reflectivity specifications).

Lighted Runways

Threshold lights. Identify runway threshold by lighting:

- a. on a runway used exclusively for visual operations use six (6) lights on each end (three on each side)
- b. on an instrumented runway, use eight (8) lights on each end (four on each side) whenever there is any likelihood that a navigation aid and commissioned approach may be placed in service at the airport.

Place threshold lights in a line perpendicular to the extended runway centerline and between 2 feet and 10 feet from the designated runway threshold. Place the innermost runway threshold light in line with the runway edge lights, and space the remaining lights evenly at 10-foot intervals outbound from the runway (figure 660-1). Use threshold lights with green and red split lenses. Position the lights so that only the red color is visible from the runway side, and only green is visible from the approach path.

Threshold cone markers. On lighted runways, use reflective cone markers in conjunction with lights to identify the runway threshold. Place a reflective cone marker over the top of each light so the light protrudes from the top of the cone marker (figures 660-1, 660-2 & 660-3). Use reflective cone markers with 180-degree green and 180-degree red reflective bands. Position the markers so that only the red color is visible from the runway side, and only green is visible from the approach path. Use a reflective band made of high intensity sheeting of sufficient width to meet FAA specifications for reflective markers (AC 150/5345-39D for reflectivity specifications).

Lighted and Unlighted Runways

Reflective threshold markers: Mark the ends of lighted and unlighted runways with reflective threshold markers. Use five (5) markers on each side of a threshold, for a total of ten (10) markers on each end (figures 660-1 & 660-2). Place the markers perpendicular to the runway centerline and space them at 1.7-foot intervals between the first two runway threshold cone markers (or cone markers with lights) (figures 660-1 & 660-2). Use markers consisting of flexible posts, not to exceed 30 inches in height, covered by reflectivity enhancers. Use orange markers with a 180-degree green band toward the approach path and a 180-degree red reflective band toward the runway (figure 660-1). Use reflective bands made of high intensity sheeting of sufficient width to meet FAA specifications for reflective markers (AC 150/5345-39D for reflectivity specifications).

Runway Edge Marking

Unlighted Runways

Reflective edge markers. Cones, flexible posts, wands or other frangible markers are a visual substitute for lights. Position them similarly to runway edge lights (AC 150/5340-30H). Line each side of the runway with a row of reflective edge markers. Place each row of edge markers parallel to the centerline and from 2 feet to 10 feet outside the edge of the designated runway. Use equidistant longitudinal spacing not to exceed 200 feet, in accordance with AC 150/5340-30H. Place markers from one edge row directly across from the markers on the opposite edge row. The area between the edge of the designated runway and the markers must support an aircraft's weight without causing damage to the aircraft. If the area between the markers and the edge of the designated runway cannot support an aircraft, place the markers on the edge of the designated runway. Use markers that are frangible and are not less than 14 inches nor more than 30 inches in height (figure 660-4). Use white reflective bands made of high intensity sheeting of sufficient width to meet FAA specifications for reflective markers (AC 150/5345-39D for reflectivity specifications).

Lighted Runways

Combination reflective edge markers and lights. Where runway lights are in place, install markers, as detailed in the previous section, either on the light (figure 660-3) or slightly outboard (figure 660-4). Use reflective bands that match the color of the runway lights (yellow/white) as appropriate. Install runway lights as per AC 150/5340-30H.

Taxiway Edge Marking

Unlighted Taxiways

Reflective edge markers. Cones, flexible posts, wands, or other frangible markers are a visual substitute for lights. Position them similarly to taxiway edge lights (AC 150/5340-30H). Line each side of the taxiway with a row of reflective edge markers. Place each row of edge markers parallel to the centerline and from 2 feet to 10 feet outside the edge of the designated taxiway. Use equidistant longitudinal spacing not to exceed 200 feet, in accordance with AC 150/5340-30H. The longitudinal spacing of the markers is influenced by the physical layout of the taxiway. The area between the edge of the designated taxiway and the markers must support an aircraft's weight without causing damage to the aircraft. If the area between the markers and the edge of the designated taxiway cannot support an aircraft, place the markers on the edge of the designated taxiway. Use markers that are frangible and are not less than 14 inches nor more than 30 inches in height (figure 660-4). Use blue reflective bands made of high intensity sheeting of sufficient width to meet FAA specifications for reflective markers (AC 150/5345-39D for reflectivity specifications).

Lighted Taxiways

Combination reflective markers and lights. Where taxiway lights are in place, install markers, as detailed in the previous section, either on the light (figure 660-3) or slightly outboard (figure 660-4). Install taxiway lights as per AC 150/5340-30H.

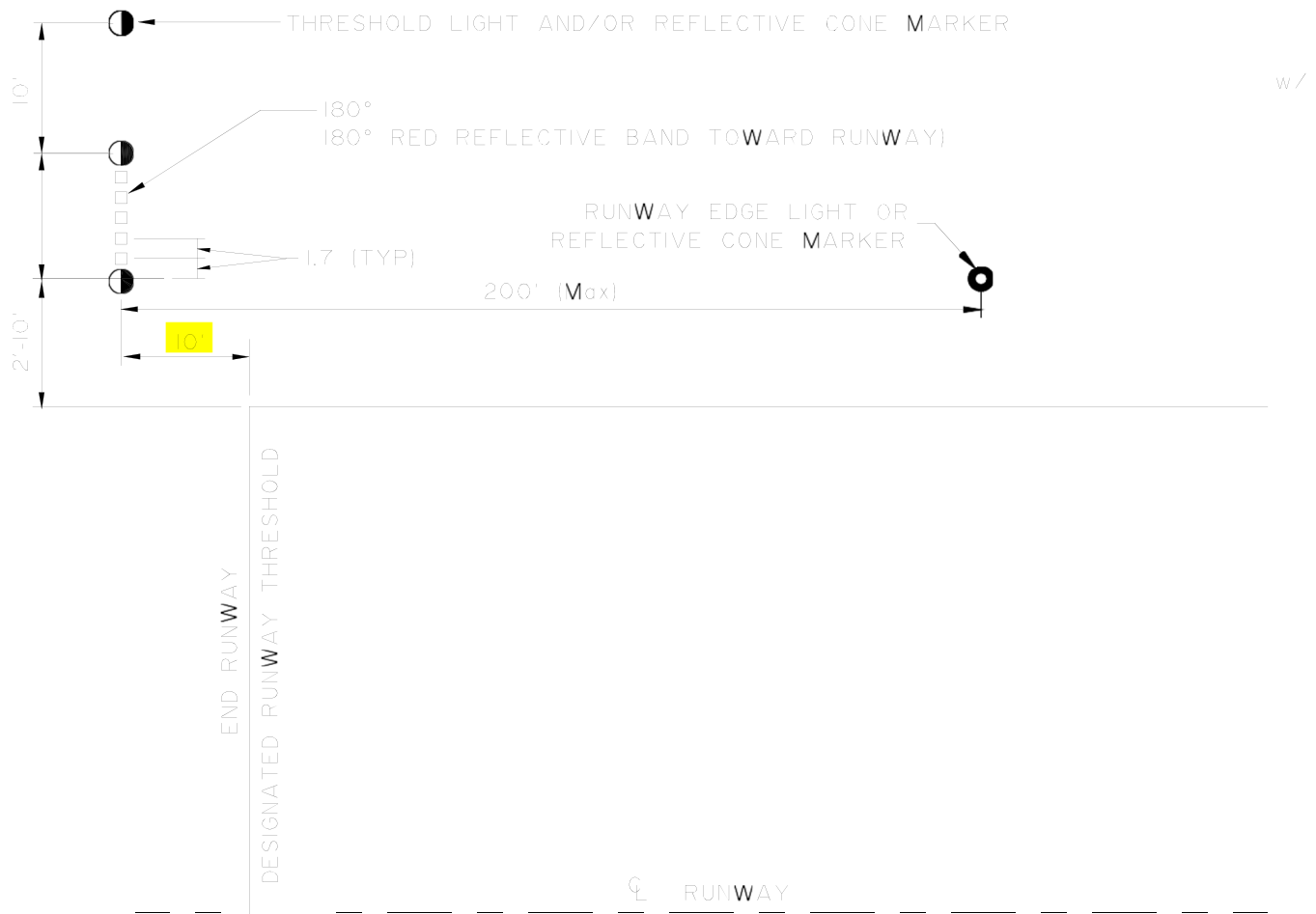

**Figure 660-1
Typical Threshold Detail
No Scale**

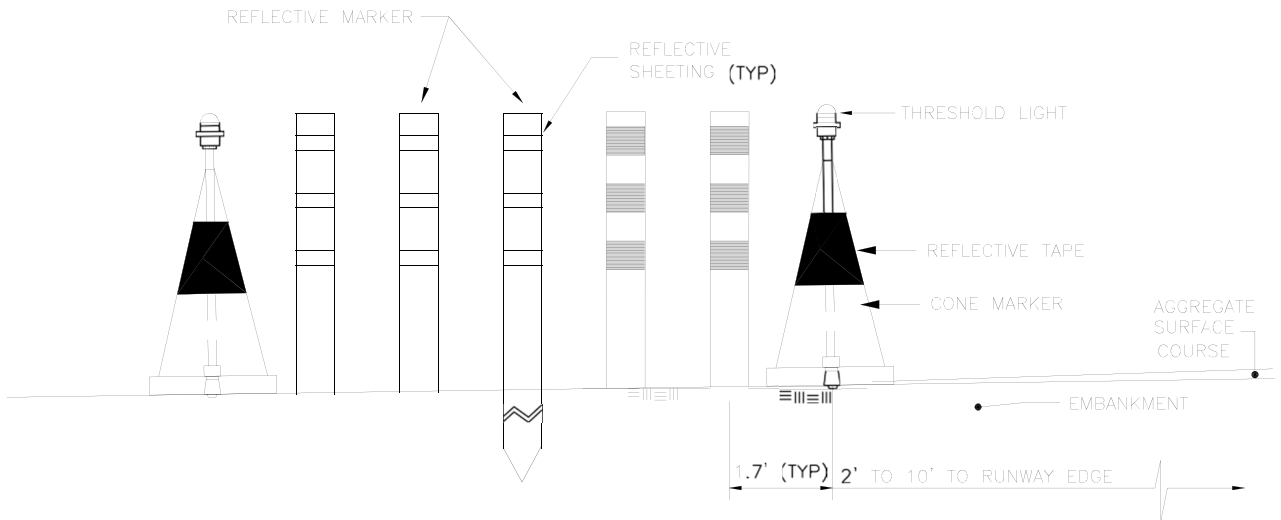

Figure 660-2
Threshold Reflective Marker Details
No Scale

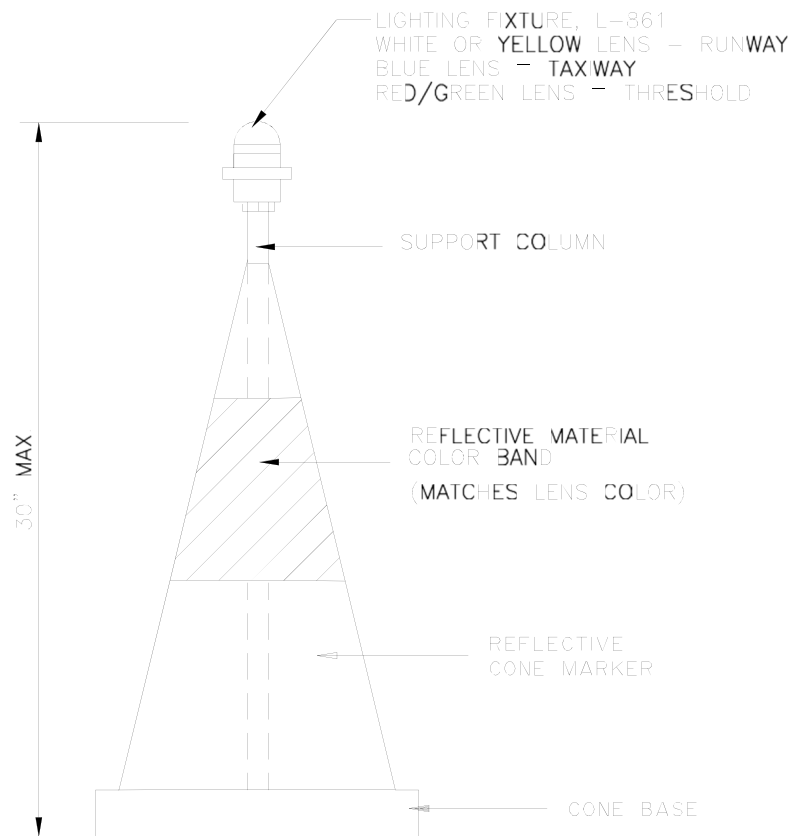

Figure 660-3
Reflective Cone Marker with Light
No Scale

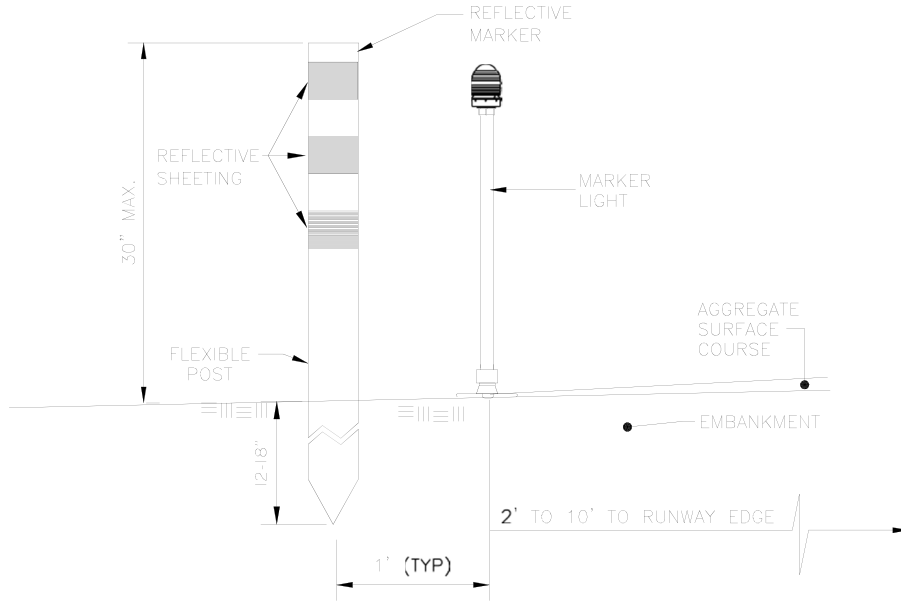

Figure 660-4
Example Detail for Runway/Taxiway Edge Reflective
Marker No Scale