

# NAPASKIAK POWER SYSTEM UPGRADE PROJECT

## ON SITE CONSTRUCTION

CIVIL DRAWINGS	
C1	VICINITY MAP
C2	DEMOLITION PLAN
C3	DEMOLITION SITE PHOTOS
C4	SITE PLAN
C5	EXISTING SITE CONTOUR PLAN
C6	GRADING PLAN
C7	TYPICAL SECTIONS
ARCHITECTURAL DRAWINGS	
A1	FLOOR PLAN, REFLECTED CEILING PLAN, CODE ANALYSIS, & GENERAL NOTES
A2	INTERIOR ELEVATIONS & DOOR/WINDOW DETAILS & SCHEDULE
A3	EXTERIOR ELEVATIONS & ROOFING NOTES & TRIM DETAILS
A4	BUILDING SECTIONS & DETAILS
STRUCTURAL DRAWINGS	
S1.1	CODE ANALYSIS, STRUCTURAL NOTES & FOUNDATION PLAN
S1.2	FOUNDATION DETAILS
S2	MODULE FRAMING PLANS & DETAILS
S3	MODULE SECTIONS DETAILS
S4	ROOF FRAMING PLAN & DETAILS
S5.1	STAIRS, LANDINGS, LOADING DOCK, & RADIATOR SUPPORT PLAN
S5.2	STAIRS/LANDINGS FABRICATION DETAILS
S5.3	LOADING DOCK FABRICATION DETAILS
S5.4	RADIATOR & CHARGE AIR COOLER SUPPORT FABRICATION DETAILS

MECHANICAL DRAWINGS	
M1.1	MECHANICAL LEGENDS & SCHEDULES
M1.2	WARNING SIGN & FIRE EXTINGUISHER PLAN, SIGN & VALVE TAG SCHEDULES
M1.3	SYSTEM START UP & SEQUENCE OF OPERATIONS
M1.4	POWER PLANT & HEAT RECOVERY VICINITY PLAN, SITE PLAN, & DETAILS
M1.5	POWER PLANT ENLARGED MECHANICAL SITE PLAN & DETAILS
M2.1	MECHANICAL PENETRATIONS PLAN, ELEVATIONS & DETAILS
M2.2	MECHANICAL PENETRATION DETAILS
M2.3	MECHANICAL SUPPORT PLANS & DETAILS
M2.4	MECHANICAL SUPPORT HORIZONTAL WALL STRUT INSTALLATION
M2.5	MECHANICAL SUPPORT VERTICAL WALL STRUT INSTALLATION
M3.1	EQUIPMENT LAYOUT PLAN, SECTION, & DETAILS
M3.2	WALL ELEVATIONS & PIPING DETAILS
M3.3	MECHANICAL DETAILS
M3.4	GENERATOR FABRICATION DETAILS
M4.1	COOLANT & HEAT RECOVERY PIPING PLAN & DETAILS
M4.2	COOLANT & HEAT RECOVERY ISOMETRICS & DETAILS
M4.3	ENGINE COOLANT & HEAT RECOVERY PIPING DETAILS
M4.4	GLYCOL STORAGE & EXPANSION TANKS FABRICATION
M5.1	DIESEL FUEL & USED OIL PIPING PLAN, DIAGRAM, & DETAILS
M5.2	DIESEL FUEL & USED OIL PIPING ELEVATIONS & DETAILS
M5.3	USED OIL HOPPER & BLENDER INSTALLATION DETAILS
M5.4	200 GALLON DAY TANK FABRICATION
M5.5	USED OIL BLENDER FILTER BANK LAYOUT & CONFIGURATION
M5.6	USED OIL BLENDER TYPICAL FILTER HOUSING DETAILS
M5.7	USED OIL BLENDER 25 GALLON HOPPER FABRICATION
M6.1	EXHAUST & CRANK VENT PLAN & DETAILS
M6.2	CHARGE AIR SYSTEM PLAN, ELEVATIONS, & DETAILS
M7.1	VENTILATION PLAN & DETAILS
M7.2	SHEET METAL FABRICATION DETAILS
M8.1	HEAT RECOVERY SYSTEM OVERALL PLAN, SCHEMATIC, & EQUIPMENT SCHEDULE
M8.2	HEAT RECOVERY SYSTEM ARCTIC PIPE DETAILS
M8.3	HEAT RECOVERY SYSTEM TYPICAL CUH WALL-MOUNT DETAILS
M8.4	HEAT RECOVERY SYSTEM TYPICAL CUH PIPING INSTALLATION DETAILS
M8.5	HEAT RECOVERY SYSTEM BUILDING A ENLARGED PLANS & DETAILS
M8.6	HEAT RECOVERY SYSTEM BUILDING B ENLARGED PLANS & DETAILS
M8.7	HEAT RECOVERY SYSTEM BUILDINGS C & D ENLARGED PLANS
M8.8	HEAT RECOVERY SYSTEM BUILDINGS E & F ENLARGED PLANS
M8.9	HEAT RECOVERY SYSTEM BUILDINGS G ENLARGED PLANS & DETAILS
FS1	FIRE SUPPRESSION SYSTEM PLAN, SECTION, LEGEND, & NOTES

ELECTRICAL – POWER PLANT	
E1.1	ELECTRICAL LEGENDS & SCHEDULES
E1.2	OVERALL POWER PLANT & HEAT RECOVERY VICINITY PLAN
E1.3	POWER PLANT ELECTRICAL SITE PLAN & DETAILS
E1.4	POWER PLANT FEEDER & STEP UP TRANSFORMER PLAN
E1.5	STEP UP TRANSFORMER BANK DEMOLITION & INTERIM CONFIGURATION
E1.6	STEP UP TRANSFORMER BANK FINAL CONFIGURATION & DETAILS
E1.7	POWER PLANT GROUNDING PLAN & FEEDER DETAILS
E1.8	POWER PLANT COMMUNICATION PLAN & DETAILS
E2	MODULE GROUNDING PLAN & DETAILS
E3.1	WIREWAY PLAN, BUILDING SECTION, & DETAILS
E3.2	ELEVATIONS & DETAILS
E3.3	ELEVATIONS & DETAILS
E4.1	RECEPTACLE & LIGHTING PLANS & PANELBOARD
E4.2	STATION SERVICE PLAN, DETAILS, & PANELBOARD
E5	INSTRUMENTATION & DATA PLAN & DETAILS
E6.1	SWITCHGEAR ENCLOSURE LAYOUT, SETTING TABLE, & DETAILS
E6.2	SWITCHGEAR ONE-LINE & DETAILS
E6.3	24VDC ENGINE WIRING JUNCTION BOX
E7.1	DAY TANK CONTROL PANEL LOGIC DIAGRAM & BILL OF MATERIALS
E7.2	DAY TANK CONTROL PANEL LAYOUT & TERMINAL STRIPS
E7.3	DAY TANK CONTROL PANEL NOTES, SEQUENCE OF OPERATIONS & INTERCONNECT DETAILS
E7.4	DAY TANK FILTER WATER INDICATION PANEL
E8.1	HEAT RECOVERY SYSTEM BUILDING A ELECTRICAL PLAN & DETAILS
E8.2	HEAT RECOVERY SYSTEM BUILDING B ELECTRICAL PLAN
E8.3	HEAT RECOVERY SYSTEM BUILDINGS C & D ELECTRICAL PLANS
E8.4	HEAT RECOVERY SYSTEM BUILDINGS E, F, & G ELECTRICAL PLANS
ELECTRICAL – DISTRIBUTION	
E10.0	DISTRIBUTION LEGEND, ABBREVIATIONS, SPECIFICATIONS & NOTES
E10.1	DISTRIBUTION DETAILS
E11.0	OVERALL DISTRIBUTION SITE PLAN
E11.1	DISTRIBUTION DEMOLITION PLAN (1 OF 4)
E11.2	DISTRIBUTION DEMOLITION PLAN (2 OF 4)
E11.3	DISTRIBUTION DEMOLITION PLAN (3 OF 4)
E11.4	DISTRIBUTION DEMOLITION PLAN (4 OF 4)
E12.1	DISTRIBUTION PLAN (1 OF 4)
E12.2	DISTRIBUTION PLAN (2 OF 4)
E12.3	DISTRIBUTION PLAN (3 OF 4)
E12.4	DISTRIBUTION PLAN (4 OF 4)

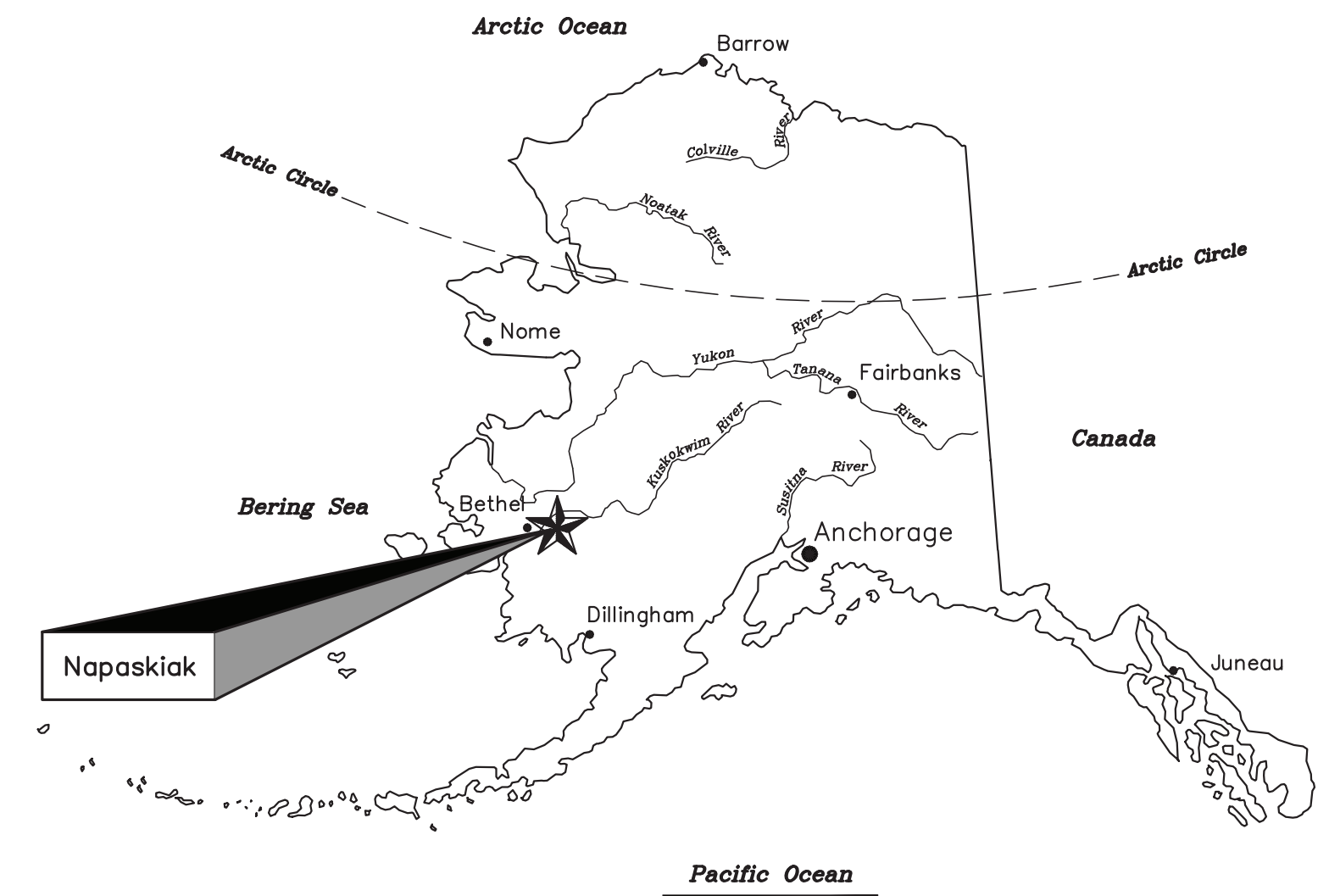

**THIS DRAWING SET INCLUDES DRAWINGS THAT SHOW WORK THAT IS INCLUDED IN THIS CONTRACT AND REFERENCE DRAWINGS THAT SHOW WORK PERFORMED UNDER THE PRIOR MODULE ASSEMBLY CONTRACT. SEE RED NOTES ON EACH SHEET FOR DELINEATION OF SCOPE.**

**THIS DRAWING SET SHOWS WORK THAT IS UNDER THE BASE BID AND ADDITIVE ALTERNATES. ALL WORK SHOWN IS INCLUDED IN THE BASE BID UNLESS SPECIFICALLY INDICATED AS ADDITIVE ALTERNATE.**

ISSUED FOR  
CONSTRUCTION  
NOV 2023

 <b>ALASKA ENERGY AUTHORITY</b>	
PROJECT: <b>NAPASKIAK POWER SYSTEM UPGRADE</b>	
TITLE: <b>ON-SITE CONSTRUCTION SCHEDULE OF DRAWINGS</b>	
DRAWN BY: BCG	SCALE: NO SCALE
DESIGNED BY: BCG	DATE: 11/13/23
FILE NAME: NAPS PP G1	SHEET:
PROJECT NUMBER:	<b>G1</b>



DRAWN BY: BCG  
 DESIGNED BY: BCG  
 FILE NAME: NAPS PP G1  
 PROJECT NUMBER:

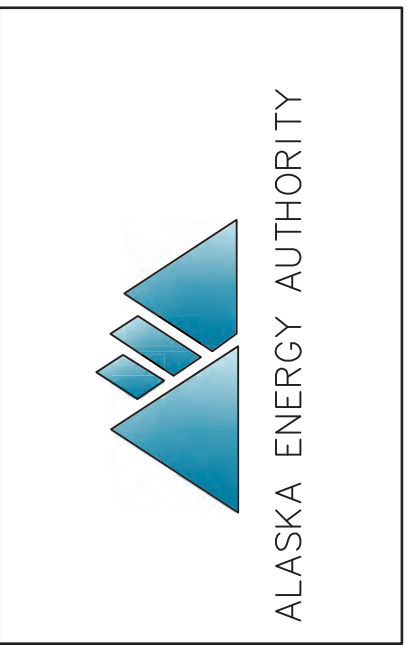

NAPASKIAK POWER SYSTEM UPGRADE  
VICINITY MAP  
NAPASKIAK, ALASKA

NO.	REVISION	BY	DATE
0	ISSUED FOR CONSTRUCTION	KH	12/15/22

Plot Date: 12/14/22	Designed: KEG
Drawn: KEG	Approved: KH

Sheet No. **C1**

1

**VICINITY MAP**

ALL WORK ON SHEETS C1 THROUGH C7 IS INCLUDED IN THE ON SITE CONTRACT.



**NOTES:**

1. EXISTING POWER PLANT MUST REMAIN OPERATIONAL UNTIL NEW POWER PLANT IS COMMISSIONED. SEE MECHANICAL AND ELECTRICAL.
2. LOCATION OF EXISTING UTILITIES AND EQUIPMENT MAY HAVE CHANGED SINCE TIME OF SURVEY. FIELD VERIFY SITE CONDITIONS AND LAYOUT.
3. THE PROJECT SITE IS AN ELEVATED SAND PAD. SEE SPECIFICATIONS FOR GEOTECHNICAL REPORT.
4. EXISTING FENCING AND ALL GATES TO REMAIN. IF PORTIONS ARE REMOVED OR DAMAGED DUE TO CONSTRUCTION ACTIVITIES REINSTALL OR REPLACE TO RESTORE TO ORIGINAL CONDITION AFTER CONSTRUCTION.
5. THE CONSTRUCTION AREA BETWEEN THE LINER CUT LINE AND THE EXISTING POWER PLANT CONTAINS A SIGNIFICANT AMOUNT OF DEBRIS INCLUDING OLD GENERATORS, PARTS, DRUMS, PALLETS, ETC. SEE PHOTOS ON SHEET C3. REMOVE ALL ITEMS FROM THIS AREA AND STACK IN A NEAT ORDERLY MANNER IN THE EQUIPMENT STOCKPILE AREA.
6. CLEAR AND GRUB VEGETATION FROM CONSTRUCTION AREA.
7. RELOCATE ONE EXISTING CONNEX TO LOCATION ON SITE PLAN C4.
8. CUT THE EXISTING MEMBRANE LINER WHERE INDICATED AND REMOVE ALL LINER ON THE EAST SIDE OF THE CUT. DISPOSE OF LINER.
9. CUT EXISTING SAND BERM WHERE INDICATED AND SPREAD MATERIAL OVER CONSTRUCTION AREA, SEE GRADING PLAN SHEET C6.

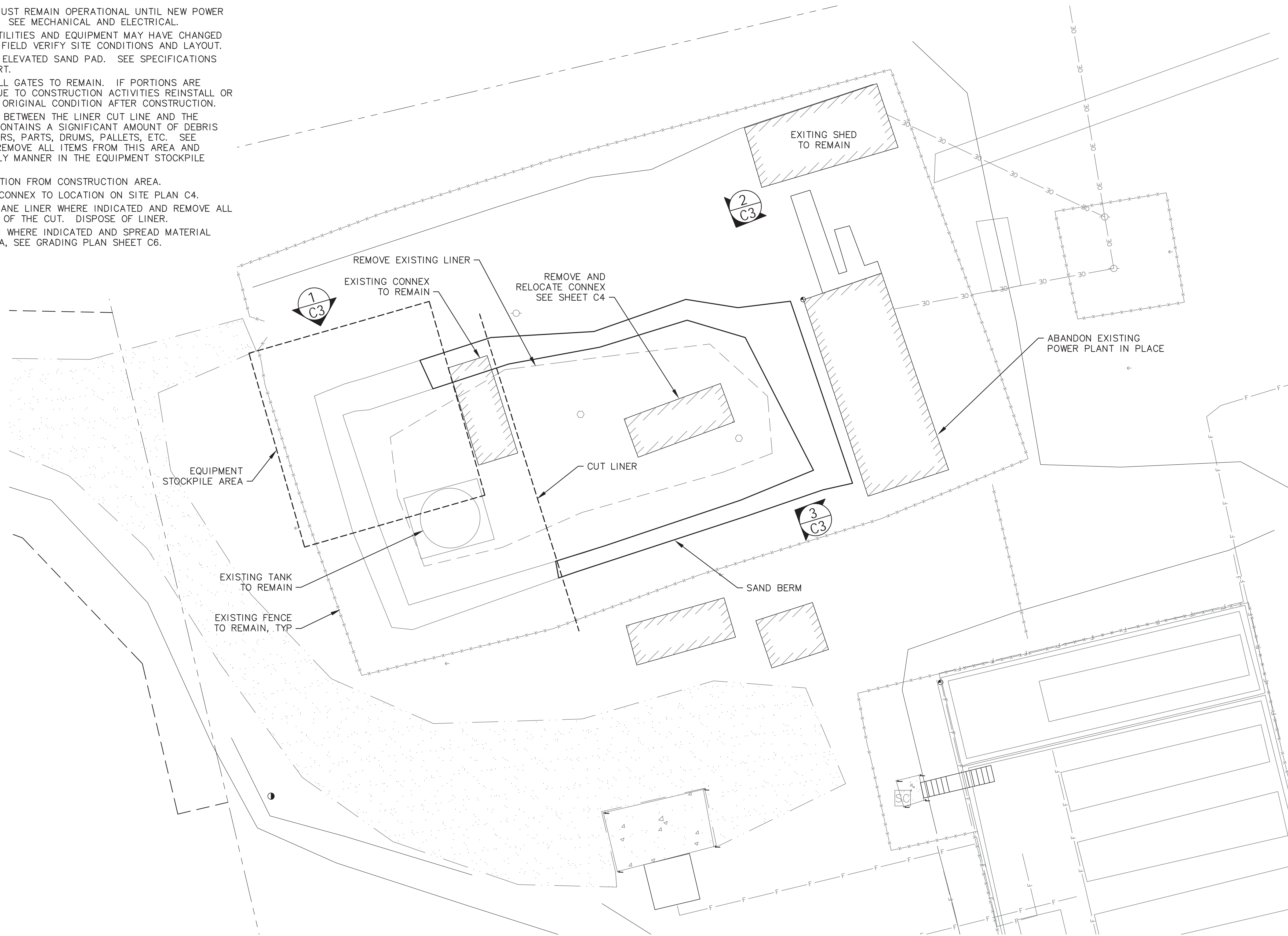

1

**DEMOLITION PLAN**



File: J:\JobsData\72309.00 Napaskiak Rpsu Project\00 Cadd 2019\01 Working Set\01 Civil\72309.00 Demolition Plan.dwg Plot Date: 12/14/2022 2:58 PM

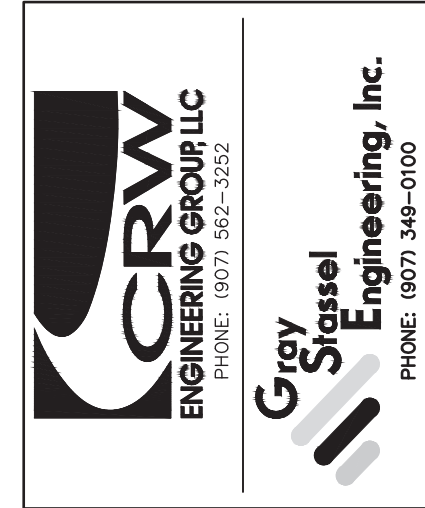

NAPASKIAK POWER SYSTEM UPGRADE  
DEMOLITION PLAN  
NAPASKIAK, ALASKA

NO.	REVISION	BY	DATE
0	ISSUED FOR CONSTRUCTION	KH	12/15/22

Plot Date 12/9/22  
Designed KEG  
Drawn KEG  
Approved KH

Sheet No. **C2**



1 SITE PHOTO - NORTHWEST



2 SITE PHOTO - NORTHEAST



3 SITE PHOTO - SOUTHEAST



NAPASKIAK POWER SYSTEM UPGRADE  
DEMOLITION SITE PHOTOS  
NAPASKIAK, ALASKA

NO.	REVISION	BY	DATE
0	ISSUED FOR CONSTRUCTION	KH	12/15/22

Plot Date 12/9/22  
Designed KEG  
Drawn KEG  
Approved KH

**NOTES:**

1. THE NEW NAPASKIAK POWER PLANT IS LOCATED ON THE SAME PARCEL OF LAND AS THE EXISTING POWER PLANT AND THE NAPASKIAK BULK FUEL STORAGE AND DISPENSING FACILITY, PLAT NO. 2003-17.
2. SEE SHEET A1 FOR CODE ANALYSIS OF NEW POWER PLANT.
3. SEE SHEET M1.4 FOR SITE LAYOUT CODE ANALYSIS AND CONFIRMATION OF DIMENSIONAL CLEARANCES.
4. LEVEL AREA AND PLACE CONNEX ON MINIMUM 4" THICK DUNNAGE.

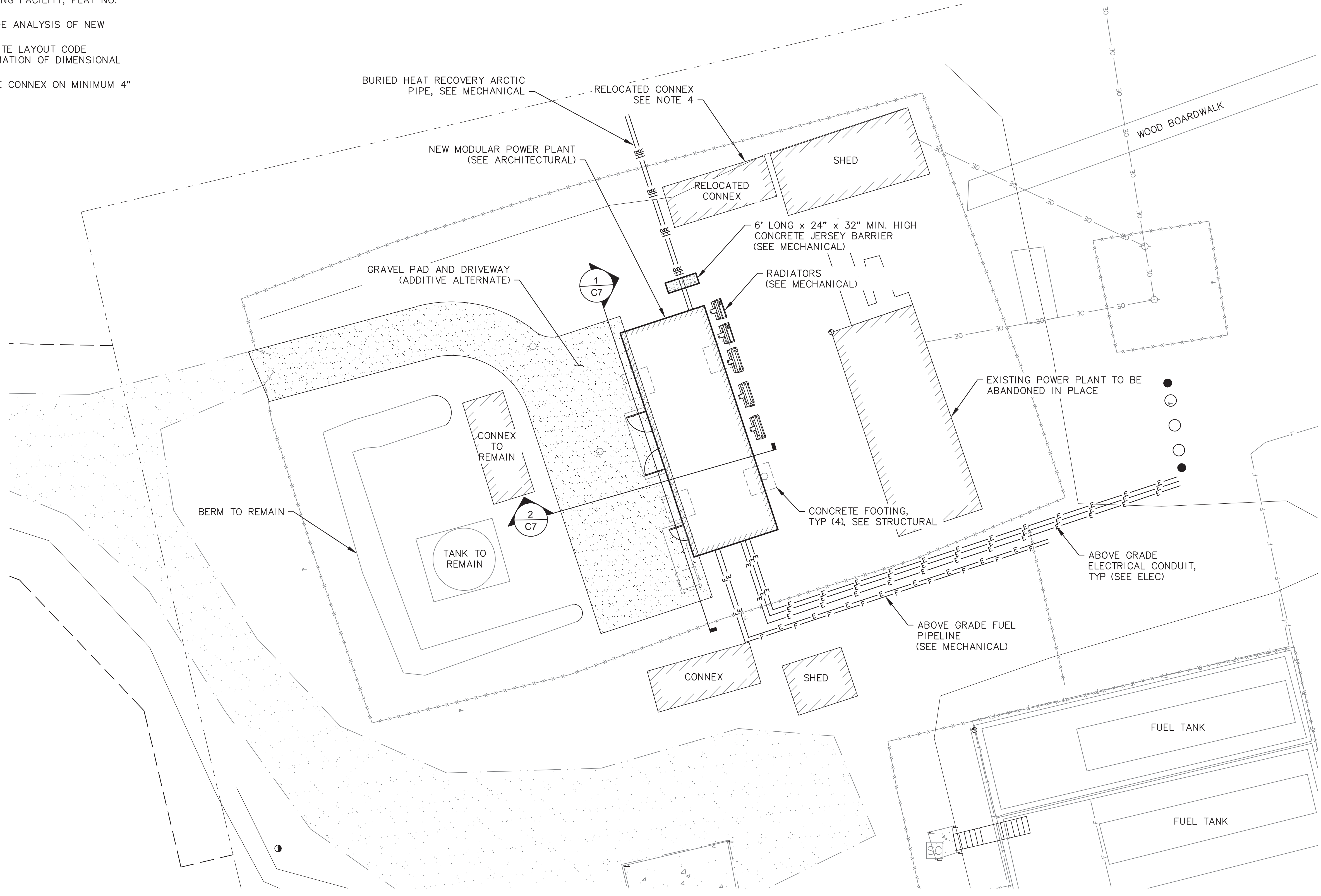

1

**SITE PLAN**



File: J:\JobsData\72309.00 Napaskiak Rpsu Project\00 Cadd 2019\01 Working Set\01 Civil\72309.00 Site Plan.dwg Plot Date: 12/14/2022 2:59 PM



**NAPASKIAK POWER SYSTEM UPGRADE**  
**SITE PLAN**  
 NAPASKIAK, ALASKA

NO.	REVISION	BY	DATE
0	ISSUED FOR CONSTRUCTION	KH	12/15/22

Plot Date	12/9/22
Designed	KEG
Drawn	KEG
Approved	KH

Sheet No. **C4**

NOTES:

- SEE SHEET C2 FOR EQUIPMENT AND LINER REMOVAL. REGRADE SITE TO FLATTEN OBSOLETE CONTAINMENT BERM IN THE PROJECT AREA.

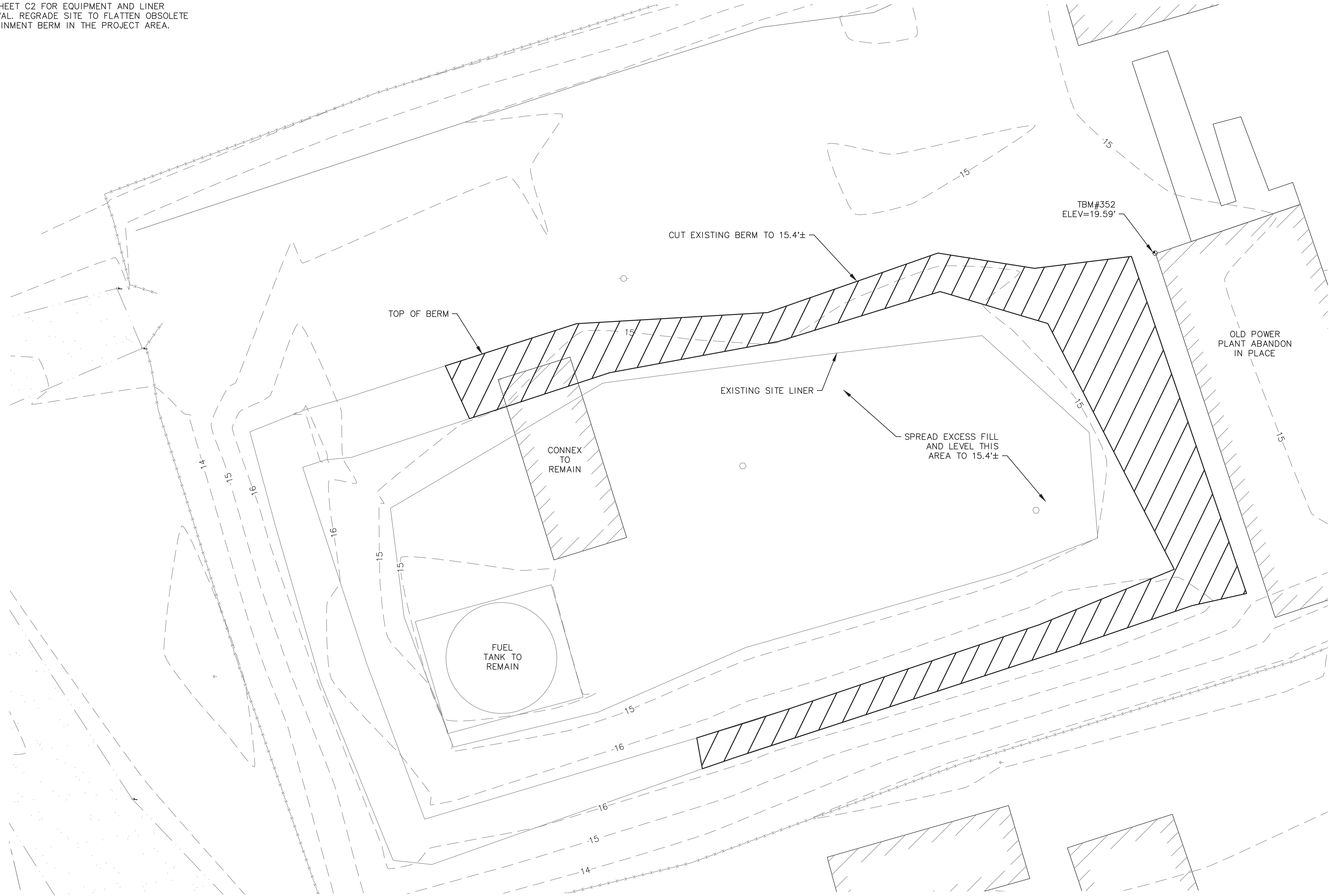

Plot Date: 12/14/2022 3:02 PM

File: J:\JobsData\72309.00 Napaskiak Rpsu Project\00 Cadd 2019\01 Working Set\01 Civil\72309.00 Existing Site Grades.dwg

**1 EXISTING SITE CONTOUR PLAN**



**NAPASKIAK POWER SYSTEM UPGRADE**  
**EXISTING SITE CONTOUR PLAN**  
 NAPASKIAK, ALASKA

NO.	REVISION	BY	DATE
0	ISSUED FOR CONSTRUCTION	KH	12/15/22

  

Plot Date	12/9/22
Designed	KEG
Drawn	KEG
Approved	KH

Sheet No. **C5**

**NOTES:**

1. UNDER BASE BID CUT EXISTING BERM, SPREAD MATERIAL OVER CONSTRUCTION SITE, LEVEL AREA AND PROOF COMPACT. FINAL GRADE SITE TO DRAIN, SEE SECTIONS SHEET C7.
2. LEVEL BASE OF CONCRETE FOOTINGS TO ELEVATION INDICATED ON SHEET C7 AND PROOF COMPACT.
3. UNDER ADDITIVE ALTERNATE PLACE 6 1/2-INCH GRAVEL CAP OVER DRIVEWAY AND PARKING AREA AS INDICATED. SPREAD GRAVEL AFTER MODULE PLACEMENT AND OTHER HEAVY CONSTRUCTION WORK. COMPACT TO 95% DENSITY.

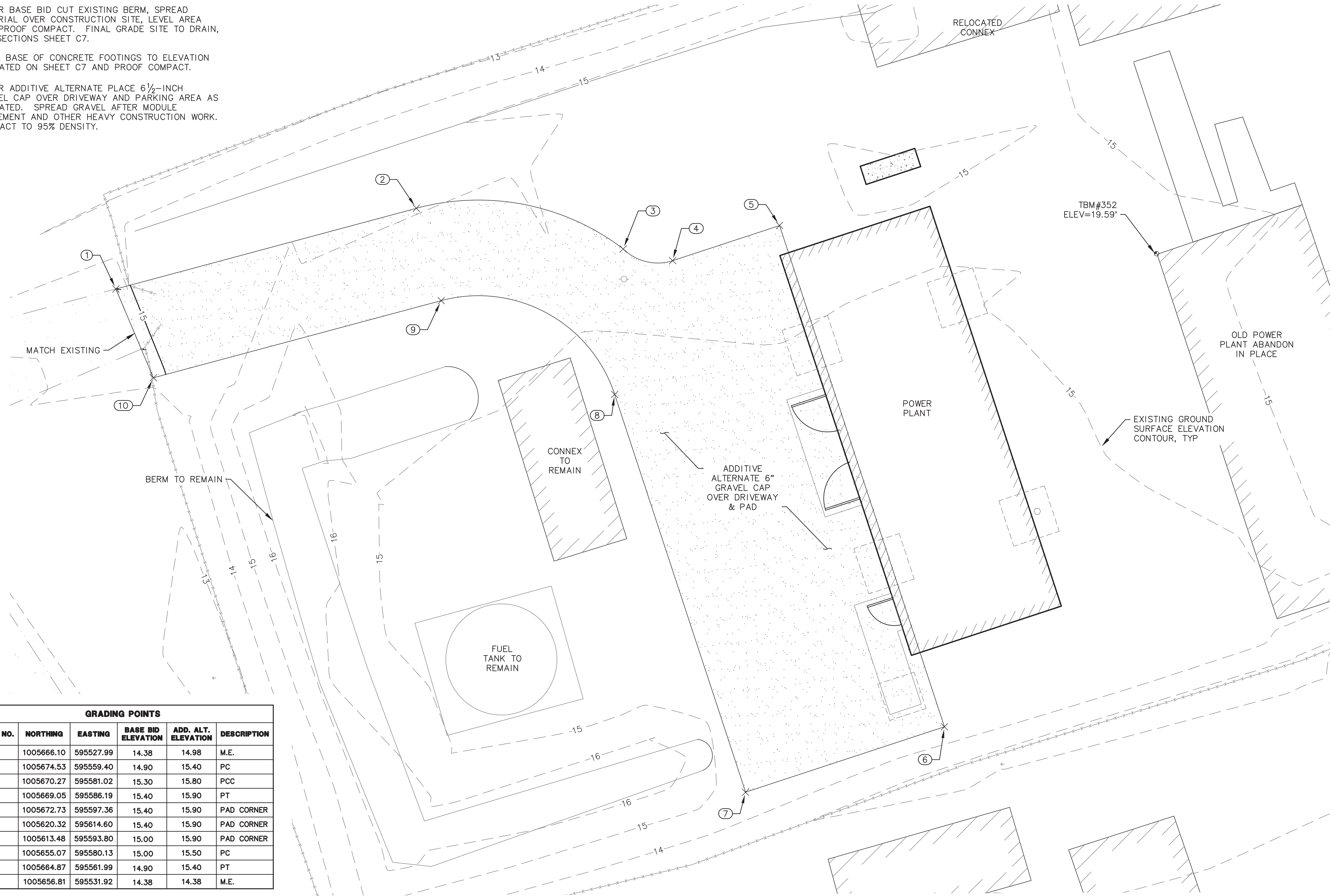

GRADING POINTS					
POINT NO.	NORTHING	EASTING	BASE BID ELEVATION	ADD. ALT. ELEVATION	DESCRIPTION
1	1005666.10	595527.99	14.38	14.98	M.E.
2	1005674.53	595559.40	14.90	15.40	PC
3	1005670.27	595581.02	15.30	15.80	PCC
4	1005669.05	595586.19	15.40	15.90	PT
5	1005672.73	595597.36	15.40	15.90	PAD CORNER
6	1005620.32	595614.60	15.40	15.90	PAD CORNER
7	1005613.48	595593.80	15.00	15.90	PAD CORNER
8	1005655.07	595580.13	15.00	15.50	PC
9	1005664.87	595561.99	14.90	15.40	PT
10	1005656.81	595531.92	14.38	14.38	M.E.

1

**FINISHED GRADING PLAN**

PROVDE GRAVEL PAD UNDER ADDITIVE ALTERNATE #2.



NAPASKIAK POWER SYSTEM UPGRADE  
GRADING PLAN  
NAPASKIAK, ALASKA

NO.	REVISION	BY	DATE
0	ISSUED FOR CONSTRUCTION	KH	12/15/22

Plot Date: 12/9/22  
Designed: KEG  
Drawn: KEG  
Approved: KH

Sheet No. **C6**

**NOTES:**

1. THE FLOOD OF RECORD FOR NAPASKIAK IS ELEVATION 17.85' AND THE RECOMMENDED BUILDING ELEVATION IS 19.85' THE POWER PLANT FINISHED FLOOR IS 1.15' ABOVE THE RECOMMENDED BUILDING ELEVATION AS INDICATED.

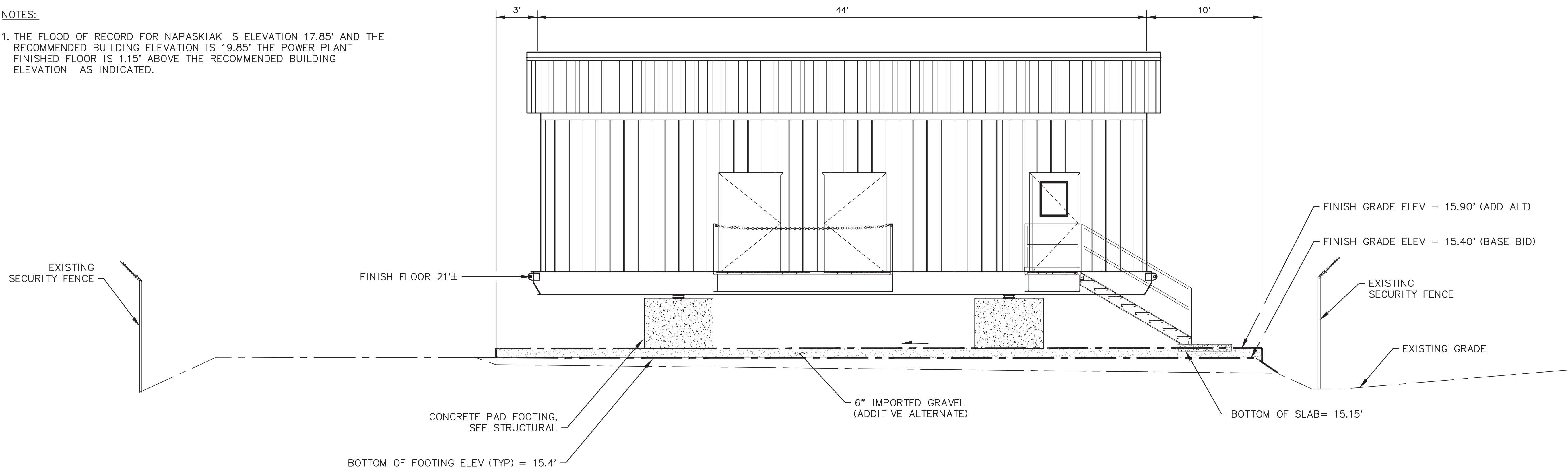

1

**TYPICAL SECTION**

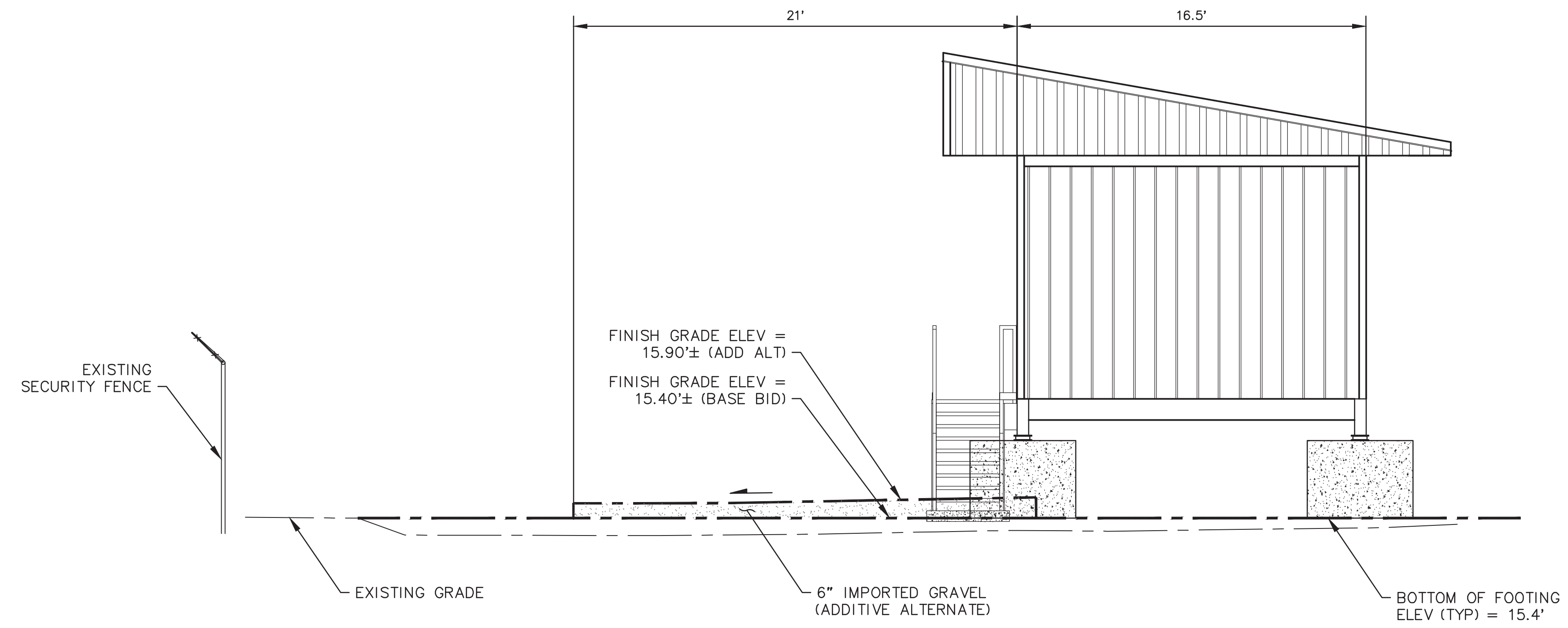

2

**TYPICAL SECTION**



File: J:\JobsData\72309.00 Napaskiak Rpsu Project\00 Coad 2019\01 Working Set\01 Civil\72309.00 Sections.dwg Plot Date: 12/14/2022 3:03 PM



NAPASKIAK POWER SYSTEM UPGRADE  
TYPICAL SECTIONS  
NAPASKIAK, ALASKA

NO.	REVISION	BY	DATE
0	ISSUED FOR CONSTRUCTION	KH	12/15/22

Plot Date: 12/9/22	Designed: KEG
Drawn: KEG	Approved: KH

Sheet No. **C7**

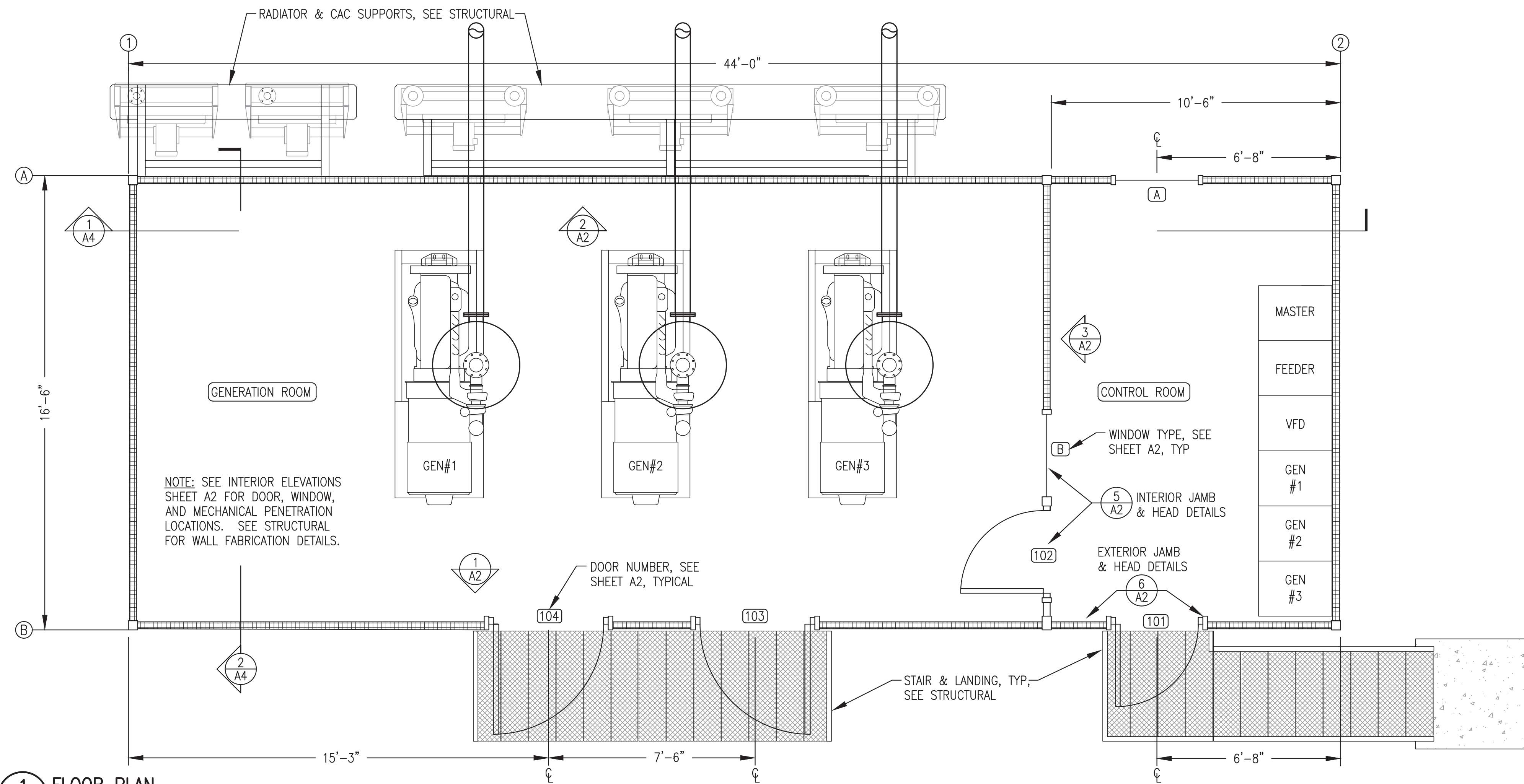

**1**  
**A1** FLOOR PLAN  
3/8"=1'-0"

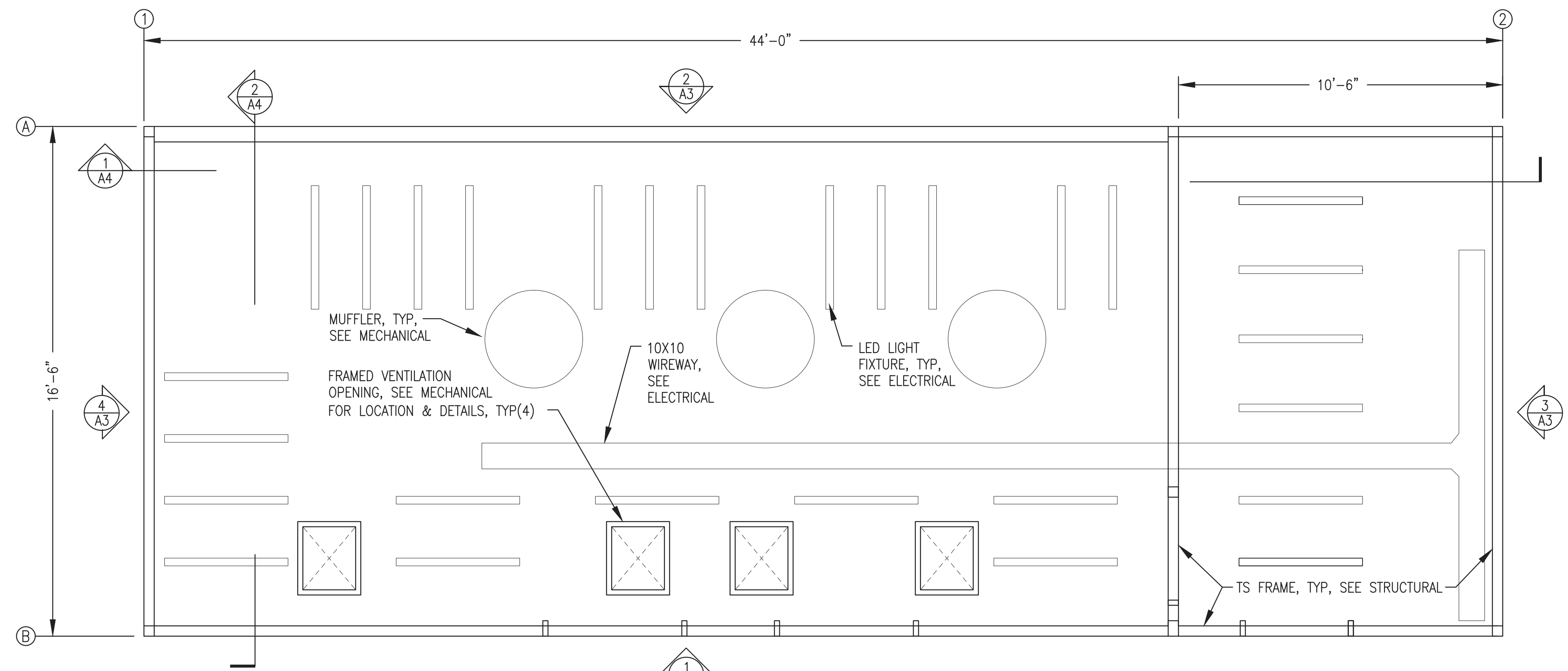

**2**  
**A1** REFLECTED CEILING PLAN  
3/8"=1'-0"

CODE ANALYSIS – 2021 EDITION INTERNATIONAL BUILDING CODE	
OCCUPANCY CLASSIFICATION	REF: IBC-2021, SEC. 306.2
GROUP F-1: FACTORY INDUSTRIAL MODERATE HAZARD – ELECTRIC GENERATION PLANT	
TYPE OF CONSTRUCTION	REF: IBC-2021, TABLE 601
TYPE V-B (NON-RATED)	REF: IBC-2021, SEC. 602.5
BUILDING HEIGHTS AND AREAS	REF: IBC-2021, TABLES 504.3, 504.4, & 506.2
MAX ALLOWED = 40'-0" 1 STORY 8,500 S.F.	ACTUAL = 18'-0" 1 STORY 730 S.F.
FIRE RESISTANCE RATING REQUIREMENTS FOR BUILDING ELEMENTS	REF: IBC-2021, TABLE 601
STRUCTURAL FRAME: 0 HR BEARING WALLS: 0 HR INTERIOR PARTITIONS: 0 HR FLOOR: 0 HR	
FIRE RESISTANCE RATING REQUIREMENTS FOR EXTERIOR WALLS	REF: IBC-2021, SEC. 705.5
EXTERIOR WALLS 10' < X < 30' 0 HR	
FIRE PROTECTION SYSTEM	REF: IBC-2021, SEC. 903.2.4
FIRE PROTECTION NOT REQUIRED. WATER MIST FIRE SUPPRESSION SYSTEM PROVIDED (SEE MECHANICAL).	
OCCUPANT LOAD	REF: IBC-2021, TABLE 1004.5
MECHANICAL/STORAGE = 300 S.F./PERSON	730 S.F./300 S.F. PER OCCUPANT = 2 OCCUPANTS
MEANS OF EGRESS – TRAVEL DISTANCE	REF: IBC-2021, TABLE 1017.2
MAX ALLOWED = 200'	ACTUAL = 42'
COMBUSTIBLE LIQUIDS STORAGE	REF: IBC-2021, TABLE 307.1(1)(i)
MAX ALLOWED = 660 GAL CLASS II LIQUIDS	ACTUAL = 200 GAL CLASS II (DIESEL FUEL DAY TANK)
MAX ALLOWED = 13200 GAL CLASS III LIQUIDS	ACTUAL = 110 GAL CLASS III (GLYCOL & LUBE OIL)
STATIONARY STORAGE BATTERY SYSTEMS	REF: IFC-2021, TABLE 1207.1.1
MAX EXEMPT = 50 GAL (FLOODED LEAD ACID)	ACTUAL = 6 GAL (6 BATTERIES AT 1 GAL MAX EACH)

- ARCHITECTURAL GENERAL NOTES:**
- SEE CIVIL SITE PLAN FOR LOCATION AND LAYOUT. PROVIDE SEPARATION TO PROPERTY BOUNDARIES IN ACCORDANCE WITH CODE ANALYSIS.
  - PROVIDE A COMPLETE AND OPERATIONAL FACILITY. ALL WORK TO BE IN ACCORDANCE WITH CURRENT APPROVED EDITIONS OF THE IBC, IMC, IFC, AND NEC INCLUDING STATE OF ALASKA AMENDMENTS.
  - SEE SHEET A2 FOR DOOR AND WINDOW DETAILS AND SCHEDULE. SEE SHEETS A3 AND A4 FOR DESCRIPTION OF FIELD INSTALLED ROOF SYSTEM.
  - INSULATE ALL WALLS, FLOORS, AND CEILINGS WITH HIGH TEMPERATURE MINERAL FIBER ACOUSTICAL FIRE BATT INSULATION, MIN R VALUE 4 PER INCH, MIN 2000F MELTING TEMP. ROXUL AFB OR EQUAL. FILL ALL PANEL VOIDS OR PROVIDE THICKNESS AS INDICATED ON DRAWINGS. MECHANICALLY FASTEN FLOOR INSULATION TIGHT TO FLOOR.
  - UPON COMPLETION OF FABRICATION ROUND ALL CORNERS AND GRIND EDGES SMOOTH AND PAINT ALL INTERIOR AND EXTERIOR EXPOSED STEEL. PERFORM ALL PAINTING IN A WARM DRY ENVIRONMENT IN ACCORDANCE WITH MANUFACTURER'S INSTRUCTIONS INCLUDING DRYING TIME TO RE-COAT.
  - SANDBLAST EXTERIOR SURFACE TO SSPC-SP-10. PRIME WITH ONE COAT OF REINFORCED INORGANIC ZINC PRIMER, DEVCO CATHA-COAT 302 OR APPROVED EQUAL, COLOR GREEN, TO 3 MILS DRY FILM THICKNESS. COVER WITH TWO COATS OF EPOXY, DEVCO BAR-RUST 236 OR APPROVED EQUAL, TO 10 MILS DRY FILM THICKNESS. FIRST COAT COLOR GRAY, SECOND COAT COLOR WHITE.
  - FINISH EXTERIOR WALLS AND SKIDS (ALL EXPOSED VERTICAL EXTERIOR SURFACES) WITH ONE COAT OF ALIPHATIC URETHANE ENAMEL, DEVCO DEVTHANE 389 OR APPROVED EQUAL, COLOR WHITE, TO 3 MILS DRY FILM THICKNESS. NOTE: TOTAL EXTERIOR COATING BUILD 16 MILS MINIMUM DRY FILM THICKNESS.
  - SANDBLAST INTERIOR SURFACE TO SSPC-SP-6. PRIME AND FINISH WITH TWO COATS OF EPOXY, PPG AMERLOC 2 VOC OR APPROVED EQUAL, TO 8 MILS TOTAL DRY FILM THICKNESS. CEILING COLOR WHITE. WALL AND FLOOR COLOR ANSI 61 GRAY. NOTE THAT FIRST COAT ON WALLS AND FLOOR MAY BE WHITE.
  - SANDBLAST ALL EXTERIOR PLATFORMS AND FABRICATIONS AND APPLY 3 COATS OF COLD GALVANIZING COMPOUND, ZRC OR EQUAL, TO 9 MILS MINIMUM DRY FILM THICKNESS. SEE STRUCTURAL.

ALL WORK ON THIS SHEET WAS PERFORMED AS PART OF THE PRIOR MODULE ASSEMBLY CONTRACT EXCEPT FOR FIELD INSTALLATION OF PREVIOUSLY FABRICATED STAIRS AND SUPPORTS AS INDICATED ON STRUCTURAL.

REV.	DESCRIPTION	DATE	BY
2	REVISED TO 2021 CODES	11/1/22	BCG
1	REVISED FOR NEW ENGINE/GENERATOR SELECTION	6/6/22	BCG

 ALASKA ENERGY AUTHORITY	
PROJECT:	NAPASKIAK POWER SYSTEM UPGRADE
TITLE:	FLOOR PLAN, REFLECTED CEILING PLAN, CODE ANALYSIS, & GENERAL NOTES
DRAWN BY: JTD	SCALE: AS NOTED
DESIGNED BY: DGT/BCG	DATE: 4/18/22
FILE NAME: NAPS PP A1-4	SHEET: A1
PROJECT NUMBER:	

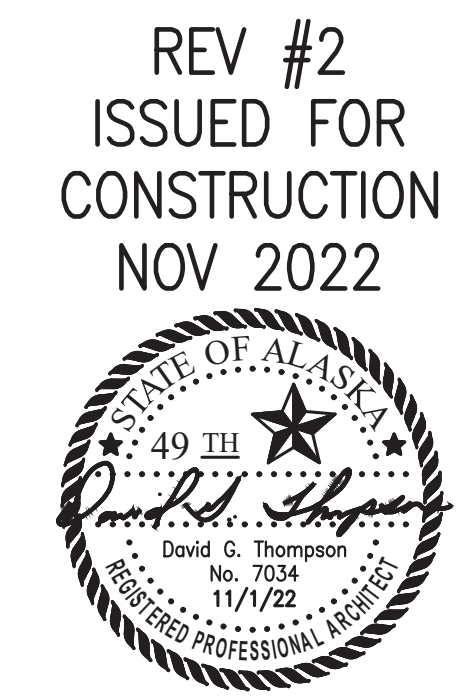

REV #2  
ISSUED FOR  
CONSTRUCTION  
NOV 2022

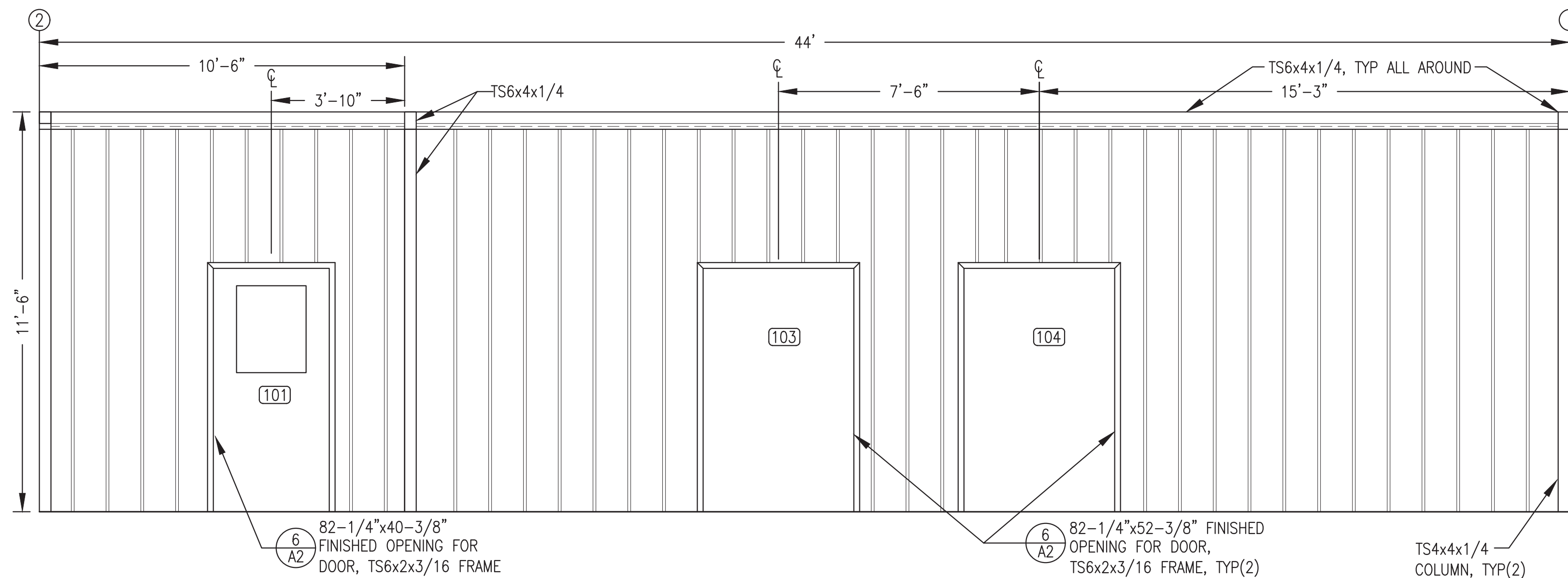

1 FRONT WALL INTERIOR ELEVATION  
3/8"=1'-0"

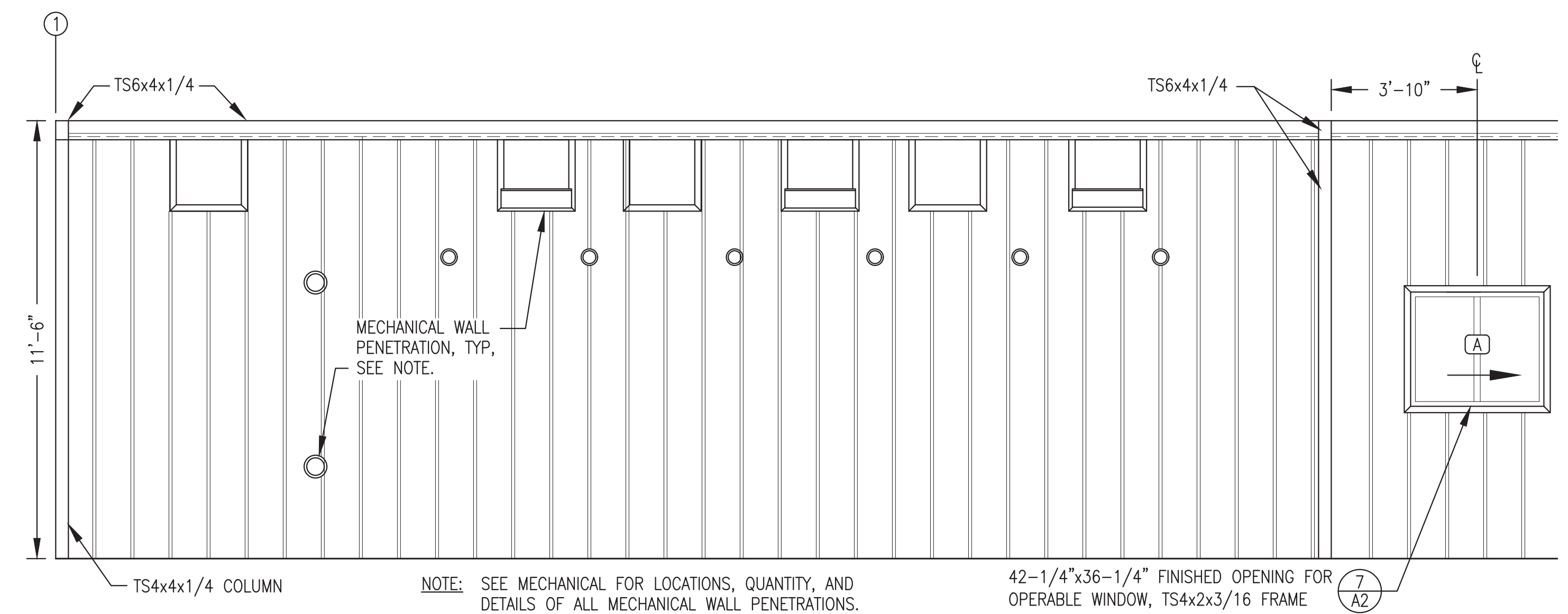

2 PARTIAL GENERATOR ROOM BACK WALL INTERIOR ELEVATION  
3/8"=1'-0"

NOTE: SET THRESHOLD IN CONTINUOUS BED OF POLYURETHANE CAULK & CAULK ENDS TO JAMB TO FORM LIQUID TIGHT CONTAINMENT.

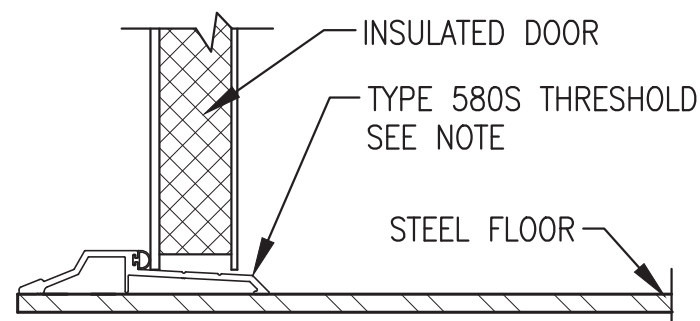

4 TYPICAL DOOR THRESHOLD  
NO SCALE

**FRAMED OPENING NOTES:**

- FABRICATE FRAMED OPENINGS FOR DOORS, WINDOWS, ETC. WITH MITERED CORNERS AND FULL PENETRATION GROOVE WELDS. GRIND OUT INSIDE OF MITERED CORNERS TO PROVIDE FULL CLEAR OPENING.
- FABRICATE TO FINISHED INSIDE (CLEAR) DIMENSIONS INDICATED AND LOCATE TO INSIDE EDGE OR CENTERLINE AS INDICATED.

DOOR CONSTRUCTION							FRAME CONSTRUCTION						
DOOR NO.	WIDTH	HEIGHT	THICK NESS	MATERIAL	CORE	REMARKS	WALL THICK.	MATERIAL	TYPE	PROFILE	PREP.	FIRE RATING	HDWR. GROUP
101	3'-0"	6'-8"	1-3/4"	16 GA. H.M.	POLYURETHANE	24"x24" RE-LIGHT {4}	N/A	16 GA. H.M.	WELDED	SINGLE RABBETED	DIMPLE & PUNCH	NONE	HW-1
102	3'-0"	6'-8"	1-3/4"	16 GA. H.M.	POLYURETHANE	24"x24" RE-LIGHT {4}	N/A	16 GA. H.M.	WELDED	SINGLE RABBETED	DIMPLE & PUNCH	NONE	HW-2
103	4'-0"	6'-8"	1-3/4"	16 GA. H.M.	POLYURETHANE		N/A	16 GA. H.M.	WELDED	SINGLE RABBETED	DIMPLE & PUNCH	NONE	HW-3
104	4'-0"	6'-8"	1-3/4"	16 GA. H.M.	POLYURETHANE		N/A	16 GA. H.M.	WELDED	SINGLE RABBETED	DIMPLE & PUNCH	NONE	HW-3

DOOR HARDWARE:				DOOR FRAME PROFILE:				
HW-1	3 EA	HINGES	HAGER BB1191 4.5 x 4.5NRP x 630	HW-3	3 EA	HINGES	HAGER BB1191 4.5 x 4.5NRP x 630	
1 EA	EXIT DEVICE	PRECISION 2108 x 4908AX3 x 630	1 EA	EXIT LOCK	SCHLAGE ND25D x RHODES x 626	1 EA	OVERHEAD STOP	ROCKWOOD OH905H x US32D
1 EA	CORE	BEST BROWN CONSTRUCTION CORE	1 EA	WEATHER STRIP	PEMCO 2891AS x 36 (HEAD)	1 EA	WEATHER STRIP	PEMCO 290AS x 80 (SIDE JAMBS)
1 EA	DOOR CLOSER	LCN 4040 x SCUSH x 689	1 EA	WEATHER STRIP	PEMCO 290AS x 80 (SIDE JAMBS)	1 EA	THRESHOLD	HAGER 580S x 48
1 EA	W/SPRING STOP		1 EA	KICK PLATE	ROCKWOOD K1050 10 x 34 x 630	<b>WINDOW TYPES:</b>  OPERABLE SLIDER WITH WHITE VINYL FRAME & 1" INSULATED GLAZING		
1 EA	KICK PLATE	ROCKWOOD K1050 10 x 34 x 630	1 EA	MOP PLATE	ROCKWOOD K1050 10 x 35 x 630	 FIXED SINGLE RABBET HOLLOW METAL FRAME WITH 2 PANES OF 1/4" LAMINATED SAFETY GLASS		
1 EA	WEATHER STRIP	PEMCO 2891AS x 36 (HEAD)	1 EA	SOUND SEAL	PEMCO 2891AS x 36 (HEAD)	<b>NOTES:</b> {1} DOORS AND HOLLOW METAL FRAMES GALVANIZED AND FACTORY PRIMED. ALL FRAMES WELDED CONSTRUCTION, DIMPLED AND PUNCHED. {2} DOORS TO HAVE SOLID POLYURETHANE INSULATION CORE WITH TOPS INVERTED AND CAULKED WATER TIGHT. {3} FINISH ALL DOORS AND HOLLOW METAL FRAMES WITH TWO COATS OF PAINT IDENTICAL TO INTERIOR WALLS AND FLOORS AS SPECIFIED ON SHEET A1. {4} INSTALL INSULATED RE-LIGHT WITH TWO PANES OF 1/4" LAMINATED SAFETY GLASS WITH 1/2" AIR GAP IN EACH DOOR PANEL, 24"x24" OR 24"x18" AS INDICATED.		
2 EA	WEATHER STRIP	PEMCO 290AS x 80 (SIDE JAMBS)	1 EA	THRESHOLD	HAGER 580S x 36	NOTE: DIMENSIONS ARE OVERALL FRAME SIZE.		

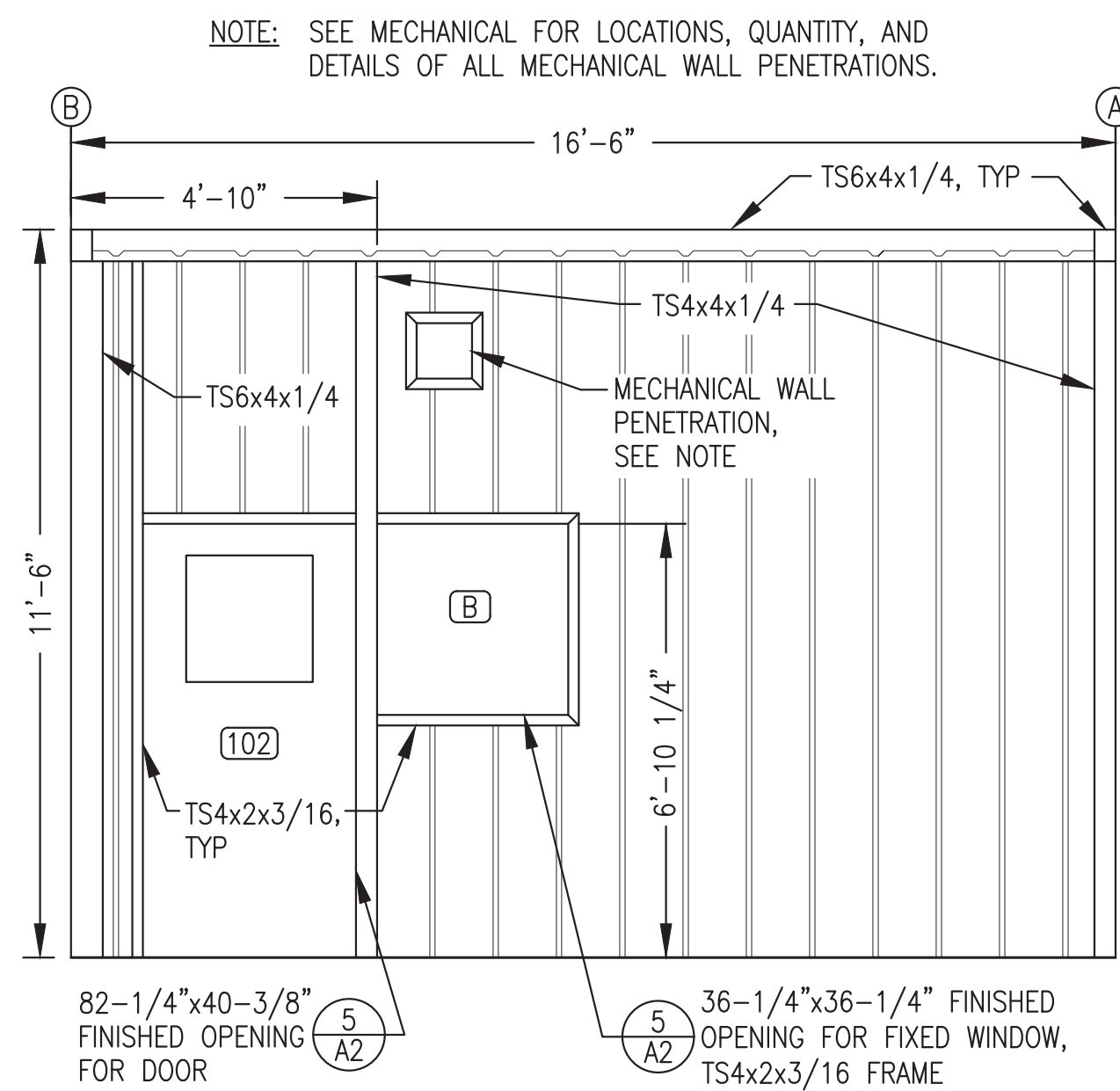

3 CONTROL ROOM WALL INTERIOR ELEVATION  
3/8"=1'-0"

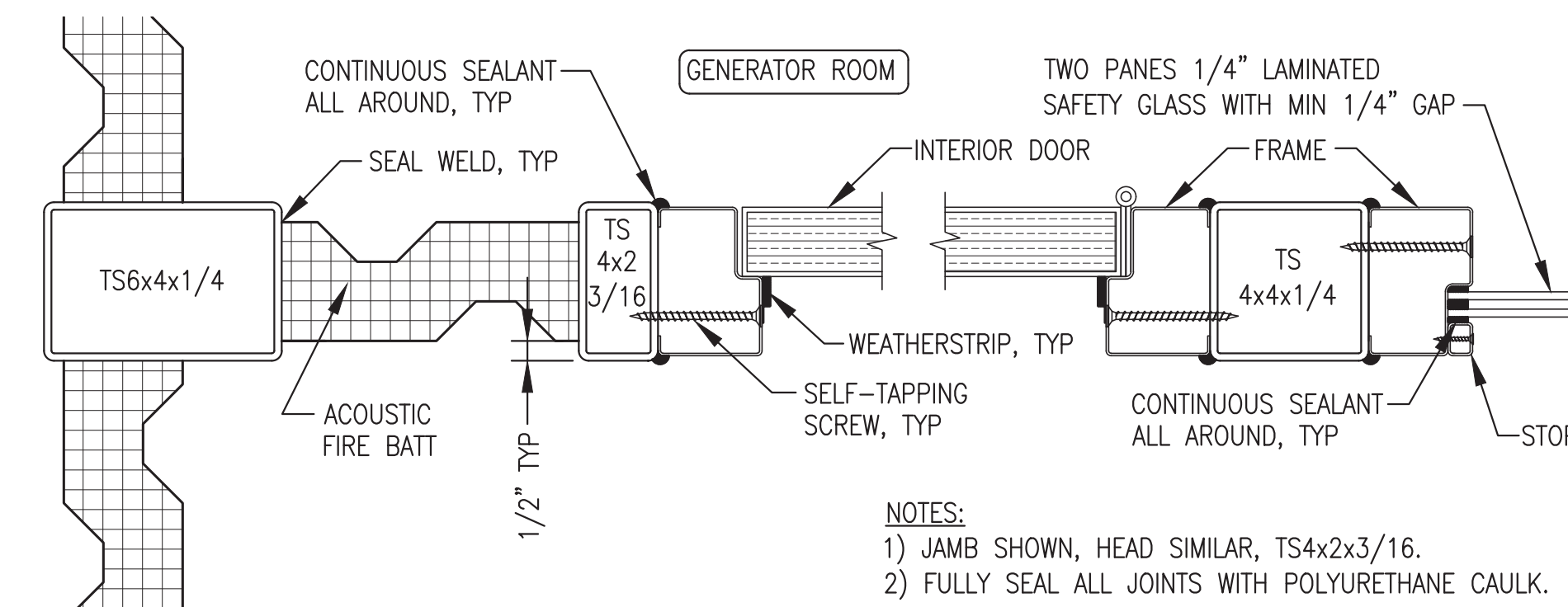

5 INTERIOR DOOR AND WINDOW JAMB/HEAD  
3"=1'-0"

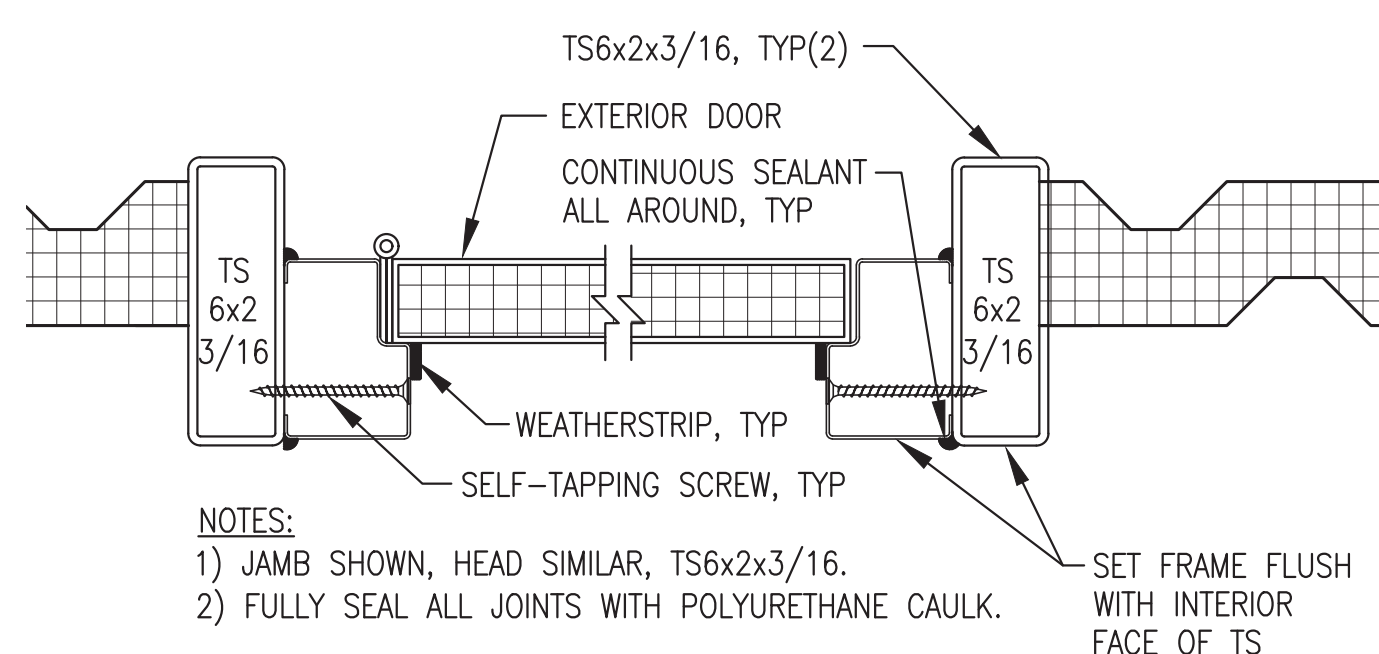

6 TYPICAL EXTERIOR DOOR JAMB/HEAD  
3"=1'-0"

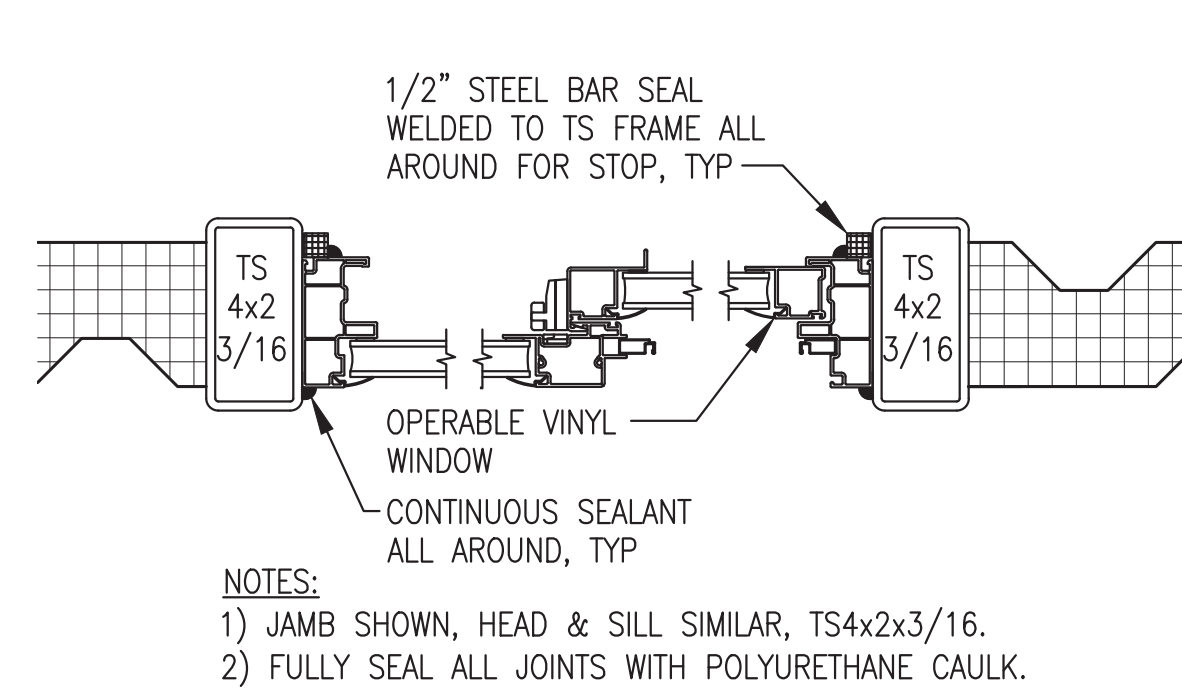

7 TYPICAL EXTERIOR WINDOW JAMB/HEAD/SILL  
3"=1'-0"

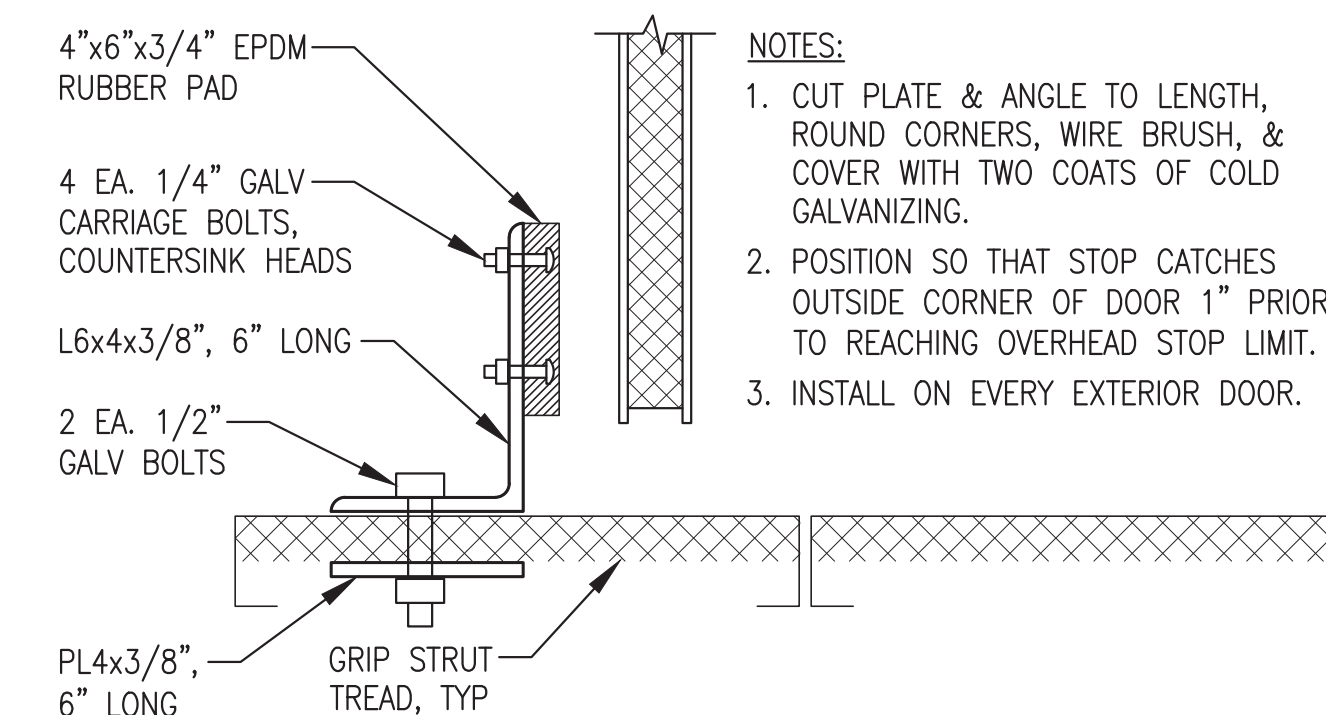

8 TYPICAL EXTERIOR DOOR BOTTOM STOP  
NO SCALE

ALL WORK ON THIS SHEET WAS PERFORMED AS PART OF THE PRIOR MODULE ASSEMBLY CONTRACT EXCEPT FURNISH AND INSTALL DOOR STOPS AS PART OF THE ON SITE CONTRACT

REV#1 ISSUED  
JUNE 2022



1	REVISED FOR NEW ENGINE/GENERATOR SELECTION	6/6/22	BCG
REV.	DESCRIPTION	DATE	BY
 ALASKA ENERGY AUTHORITY			
PROJECT: NAPASKIAK POWER SYSTEM UPGRADE			
TITLE: INTERIOR ELEVATIONS & DOOR/WINDOW DETAILS & SCHEDULE			
DRAWN BY: JTD		SCALE: AS NOTED	
DESIGNED BY: DGT/BCG		DATE: 4/18/22	
FILE NAME: NAPS PP A1-A4		SHEET: A2	
PROJECT NUMBER: P.O. 111405, Anchorage, AK 99511 (907)349-0100			

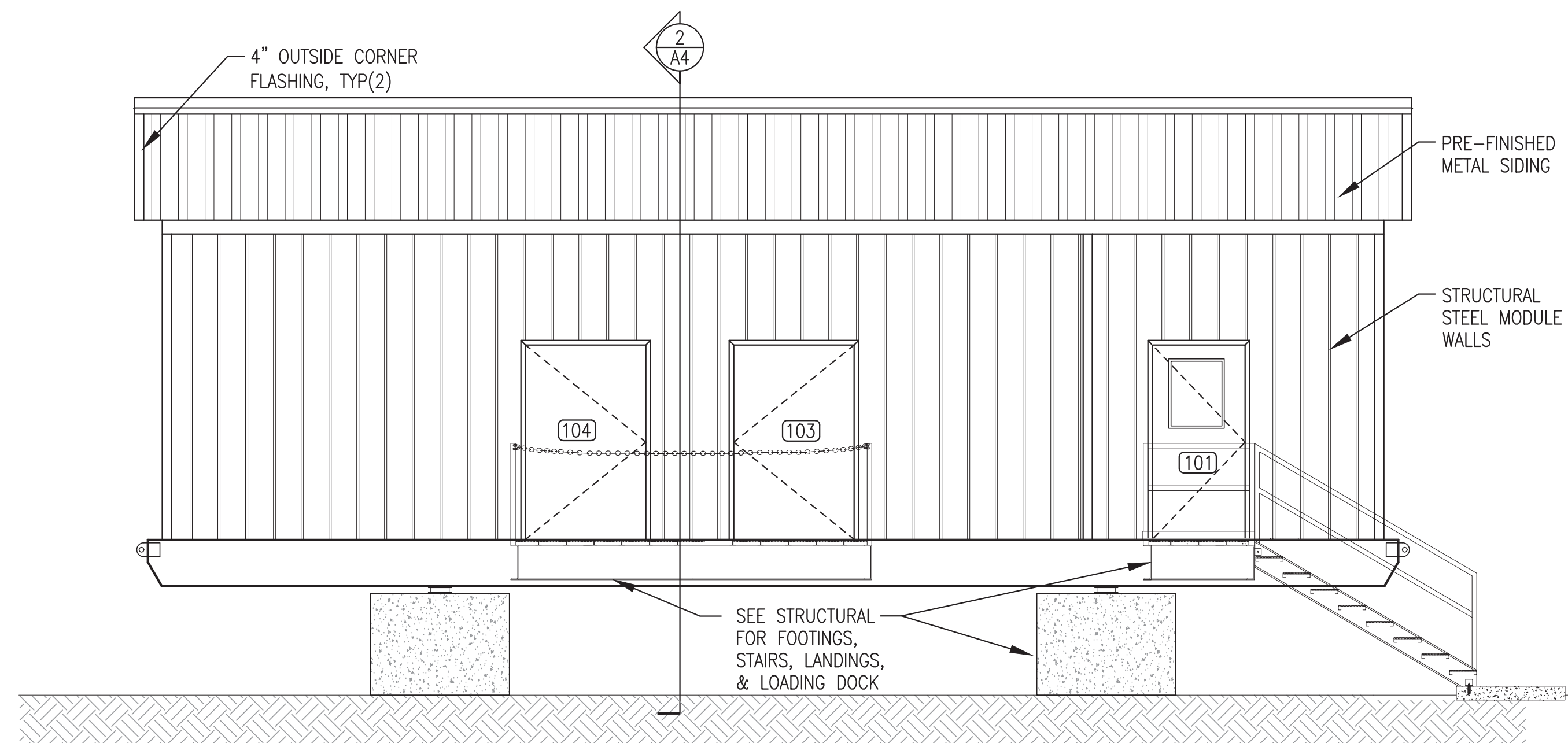

**1 FRONT EXTERIOR ELEVATION**  
1/4"=1'-0"

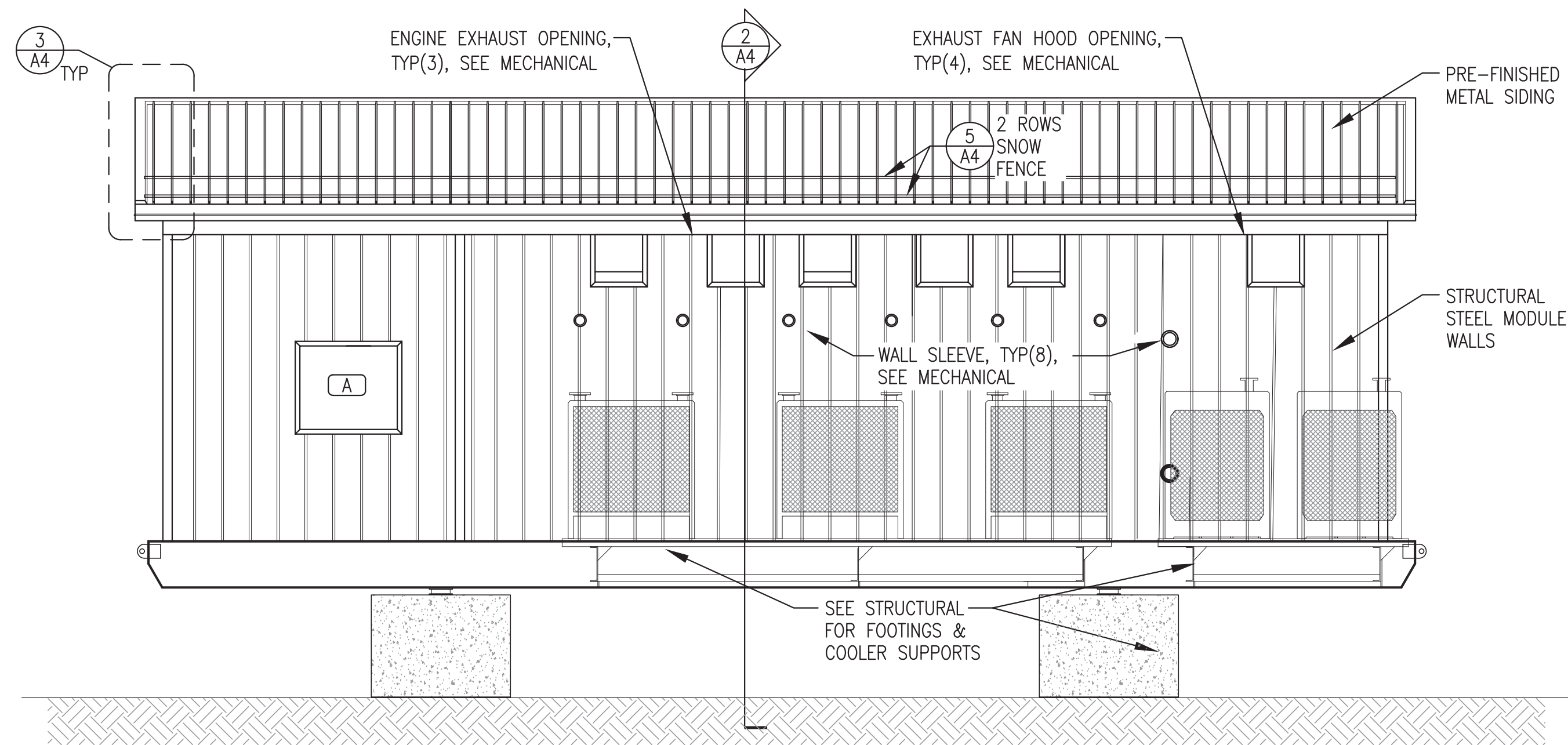

**2 BACK EXTERIOR ELEVATION**  
1/4"=1'-0"

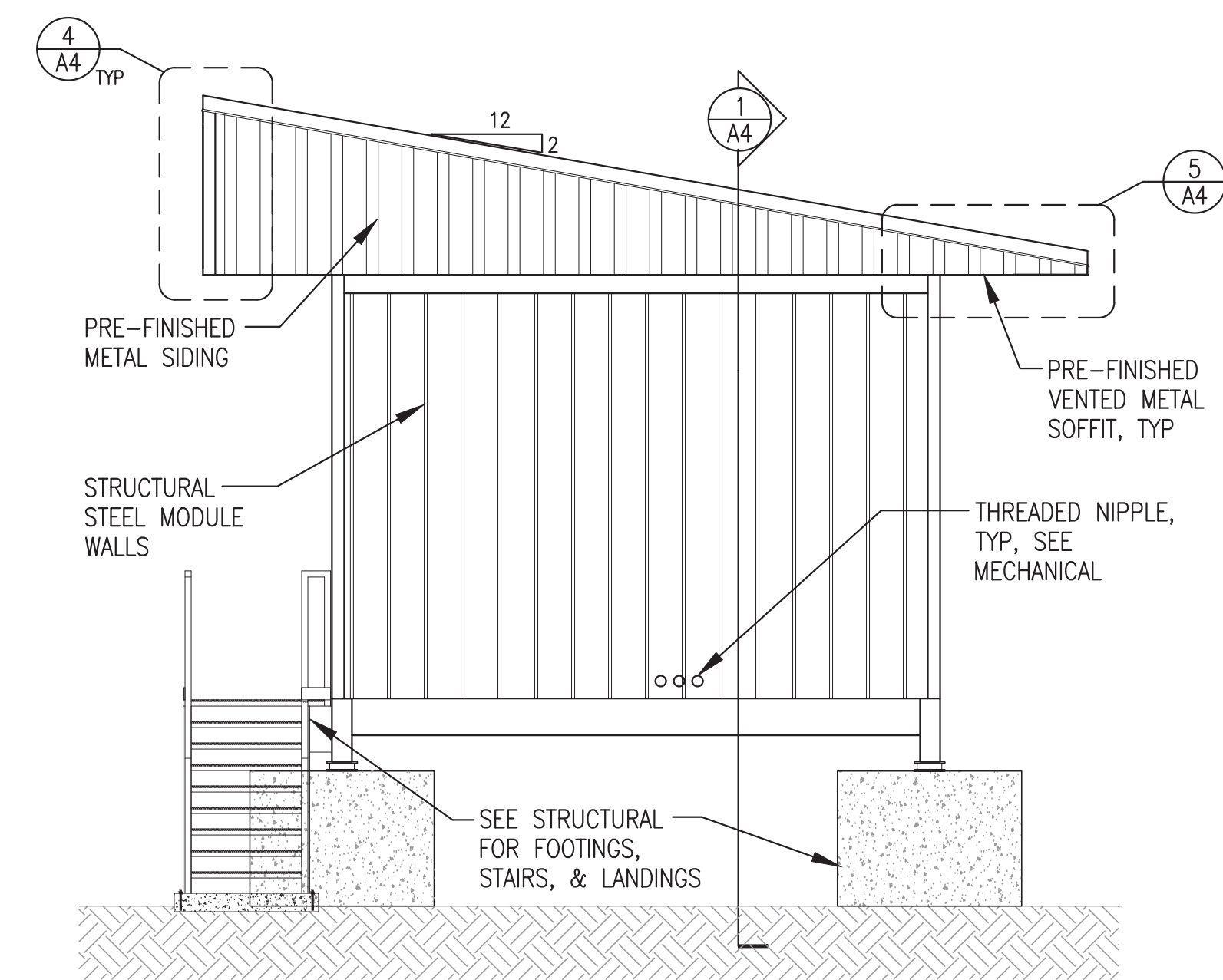

**3 END EXTERIOR ELEVATION**  
1/4"=1'-0"

**ROOFING SYSTEM NOTES:**

- 1) FIELD INSTALL TRUSSES TO MODULE STRUCTURE, SEE STRUCTURAL. FIELD INSTALL PLYWOOD SHEATHING, ICE AND WATER SHIELD, AND METAL ROOFING/SIDING AS INDICATED. SEAL AND FLASH ALL SEAMS TO FORM A CONTINUOUS WEATHERPROOF SEAL.
- 2) ALL ROOFING, SIDING, SOFFIT, TRIM, AND FLASHING SHALL BE MIN 24 GAUGE GALVANIZED STEEL WITH KYNAR FINISH, COOL MATTE BLACK. ALL FASTENERS SHALL BE CORROSION RESISTANT COATED SCREWS AND RIVETS.
- 3) ROOFING SHALL BE MECHANICAL STANDING SEAM TYPE, 24 GAUGE, 16" NET COVERAGE, 2" HIGH RIBS AT 16" O.C. WITH TWO PENCIL RIBS BETWEEN. AEP SPAN SPAN LOK HP OR EQUAL. FURNISH CLIPS AND FASTENERS AS REQUIRED TO MEET LOAD CONDITIONS INDICATED ON SHEET S1.
- 4) SIDING SHALL BE LOW PROFILE, 24 GAUGE, 36" NET COVERAGE, 1-1/4" HIGH MAJOR RIBS AND 1/4" HIGH MINOR RIBS AT 12" O.C. AEP SPAN SUPER-SPAN OR EQUAL. FURNISH FASTENERS AS REQUIRED TO MEET LOAD CONDITIONS INDICATED ON SHEET S1.1.
- 5) VENTED SOFFIT PANELS SHALL BE 24 GAUGE GALVANIZED STEEL, 12" NET COVERAGE, KYNAR FINISH, 1" STANDOFF FROM SUBSTRATE, CONCEALED FASTENERS, WITH TWO PENCIL RIBS PROVIDING MINIMUM 7.8% NET FREE AREA. AEP SPAN FLUSH PANEL OR EQUAL.
- 6) SEE SHEET A4 FOR ROOF MOUNTED SNOW FENCE.

**ROOFING SYSTEM TRIM & FLASHING:**

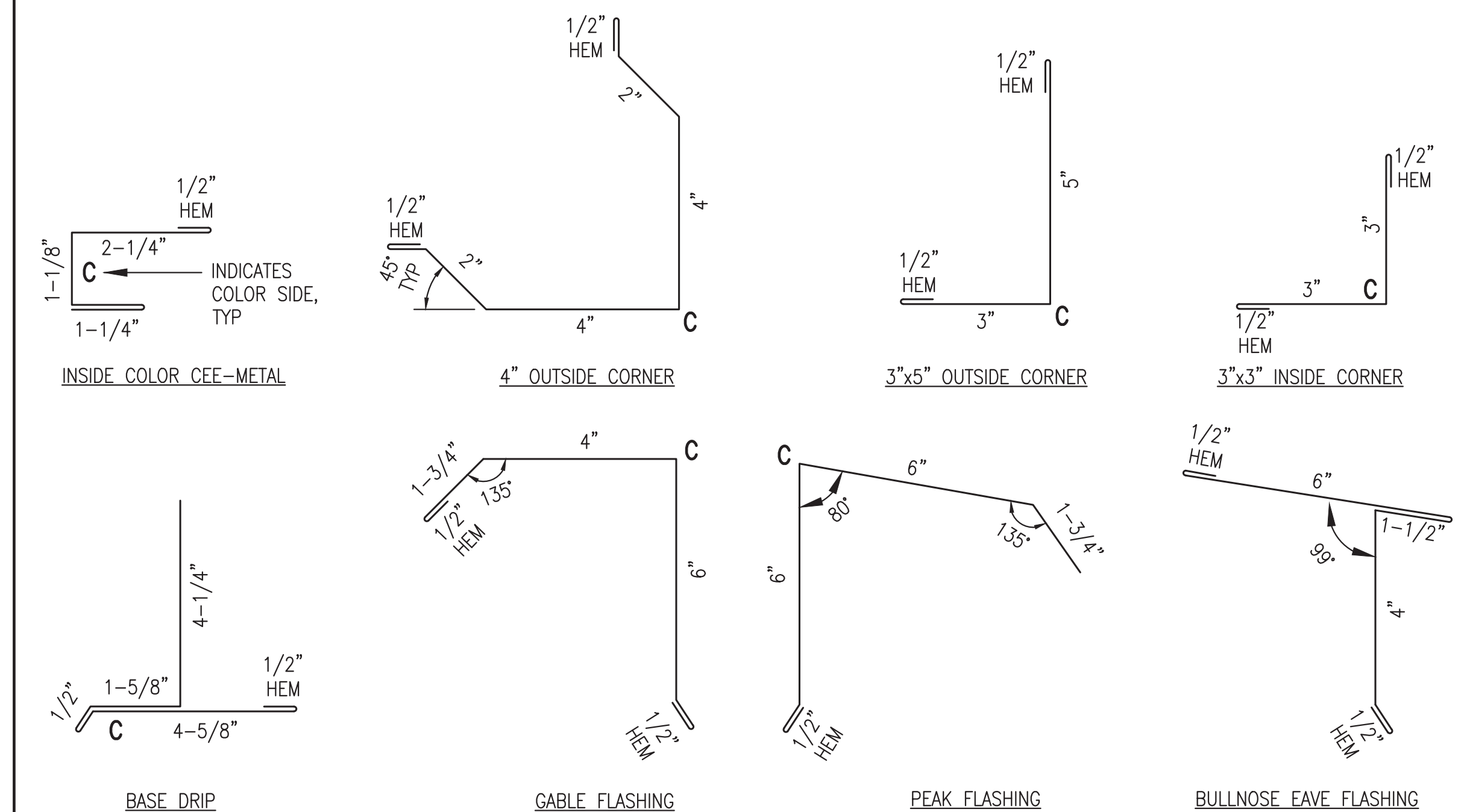

**FIELD INSTALLED ROOF SYSTEM AND FOOTINGS SHOWN THIS SHEET IS INCLUDED IN THE ON SITE CONTRACT.**

**REVISION #2  
ISSUED JULY  
2022**



2	REVISED ROOF SYSTEM COLOR PER COMMUNITY REQUEST	7/15/22	BCG
1	REVISED FOR NEW ENGINE/GENERATOR SELECTION	6/6/22	BCG
REV.	DESCRIPTION	DATE	BY

**ALASKA ENERGY AUTHORITY**

PROJECT: **NAPASKIAK POWER SYSTEM UPGRADE**

TITLE: **EXTERIOR ELEVATIONS & ROOFING NOTES & TRIM DETAILS**

	DRAWN BY: JTD DESIGNED BY: DGT/BCG FILE NAME: NAPS PP A1-A4 PROJECT NUMBER:	SCALE: AS NOTED DATE: 4/18/22 SHEET: <b>A3</b>
--	--	---

P.O. 111405, Anchorage, AK 99511 (907)349-0100

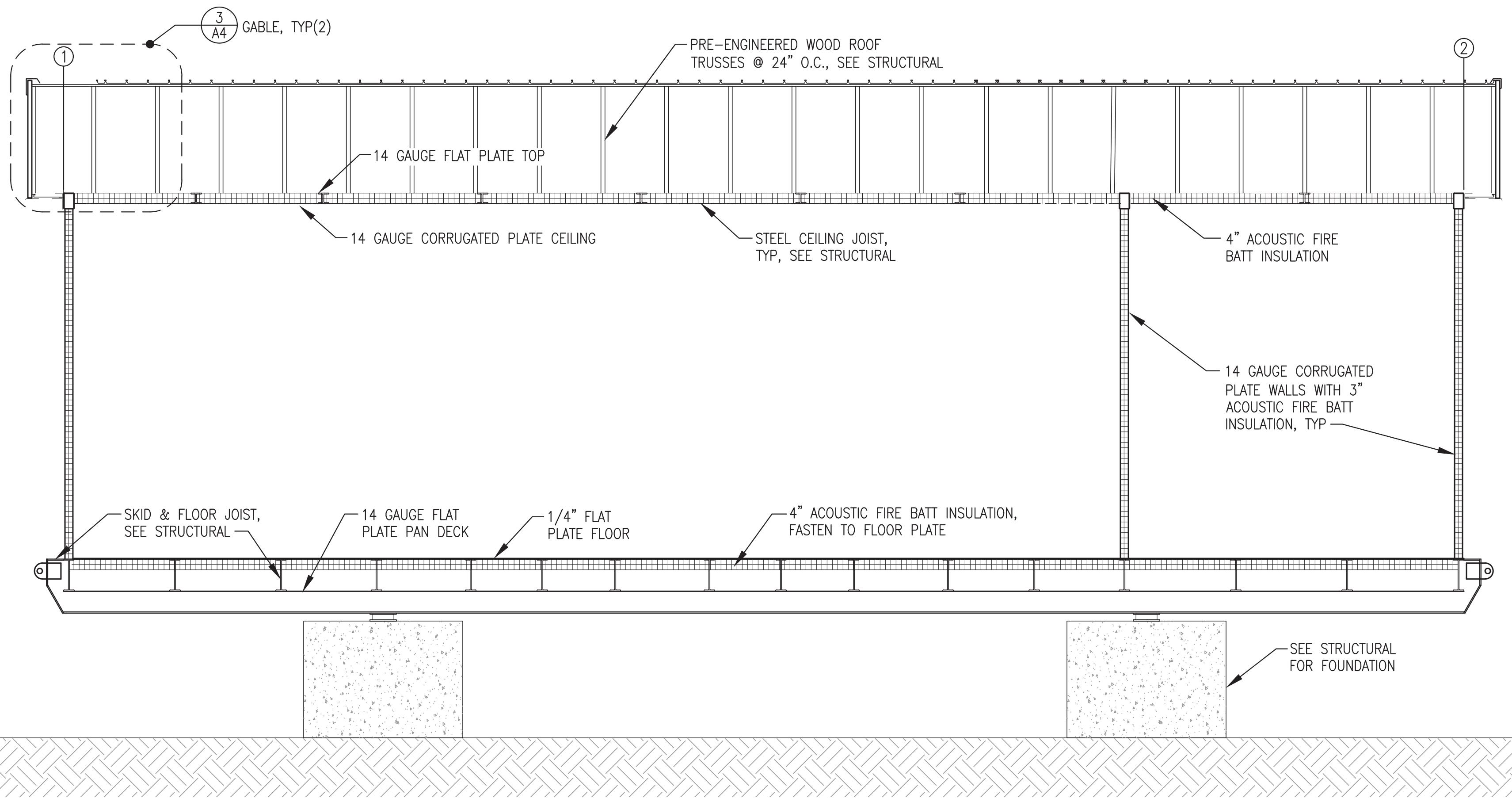

**1** BUILDING SECTION  
A4 3/8"=1'-0"

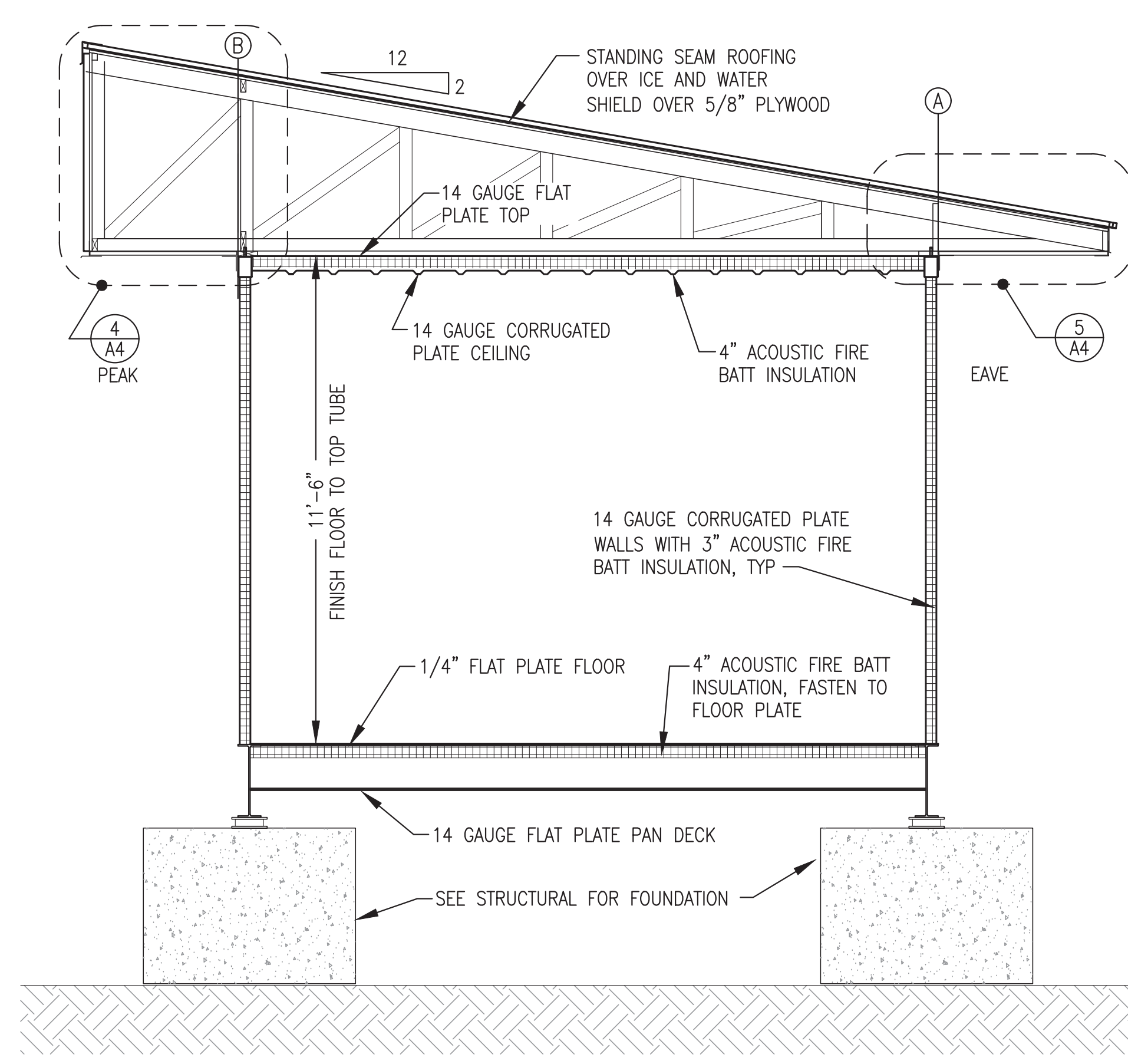

**2** BUILDING SECTION  
A4 3/8"=1'-0"

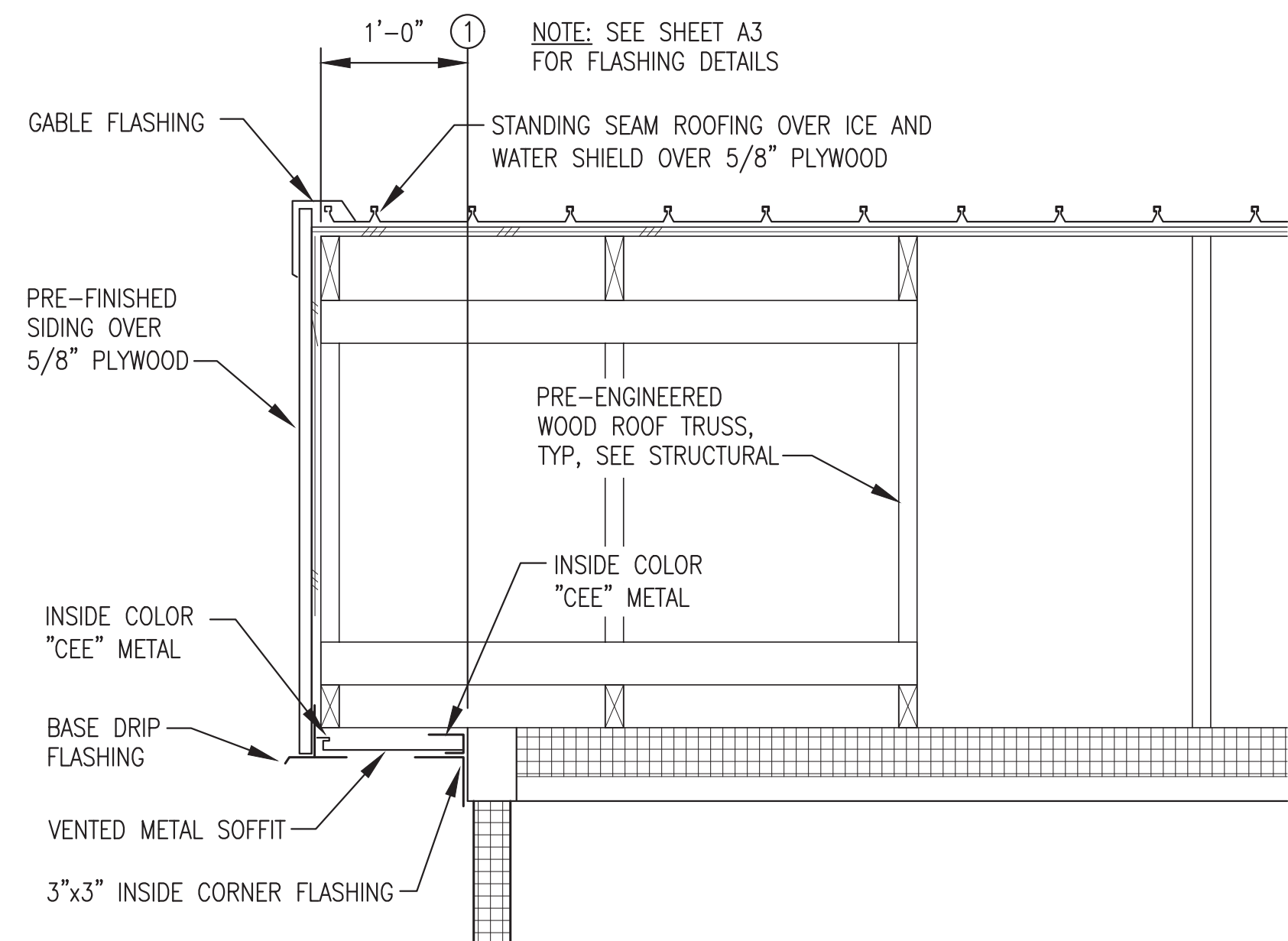

**3** GABLE DETAIL  
A4 1"=1'-0"

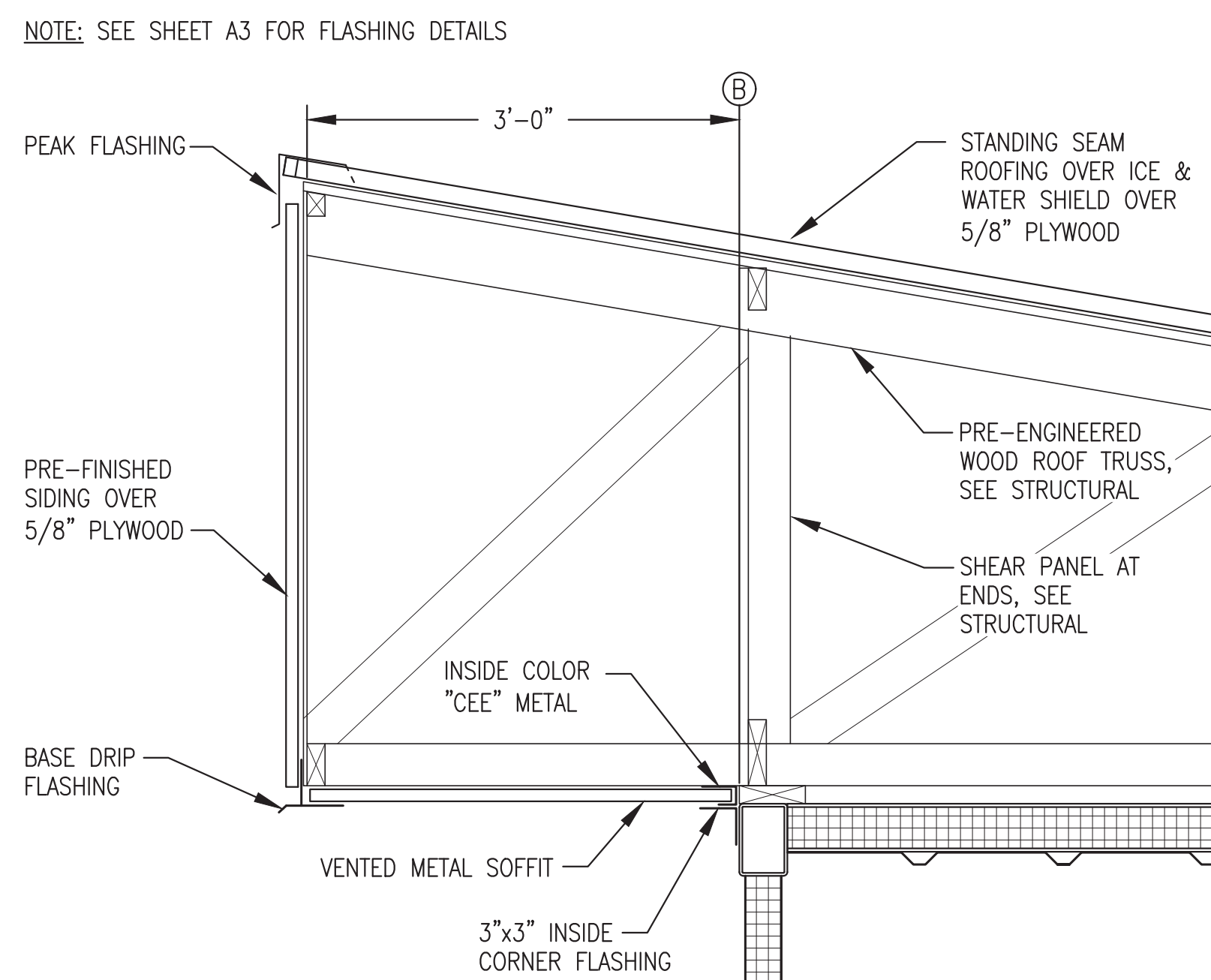

**4** PEAK DETAIL  
A4 1"=1'-0"

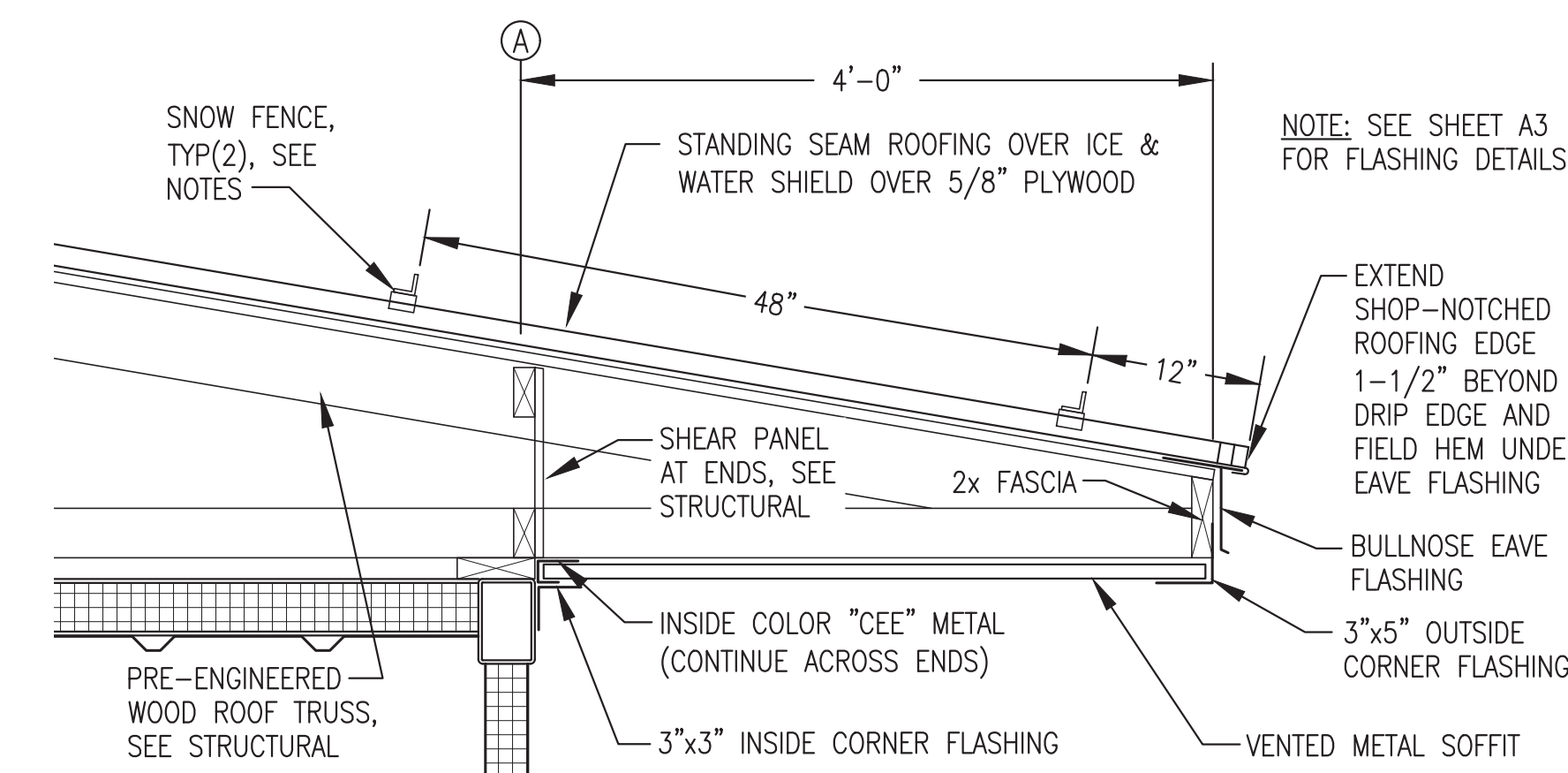

**5** EAVE DETAIL  
A4 1"=1'-0"

**SNOW FENCE NOTES:**

- 1) PROVIDE 2 ROWS OF SNOW RETENTION FENCE AS INDICATED.
- 2) SNOW FENCE SHALL BE L.M. CURBS COLOR GUARD OR APPROVED EQUAL. FURNISH COMPLETE SYSTEM INCLUDING UNPUNCHED COLOR GUARD, SPLICES, VERSA CLIPS, SNO CLIPS III, S5-U CLAMPS, AND ALL REQUIRED FASTENERS.

FIELD INSTALLED ROOF SYSTEM AND FOOTINGS SHOWN THIS SHEET IS INCLUDED IN THE ON SITE CONTRACT.

REV#1 ISSUED  
JUNE 2022



1	REVISED FOR NEW ENGINE/GENERATOR SELECTION	6/6/22	BCG
REV.	DESCRIPTION	DATE	BY
 ALASKA ENERGY AUTHORITY			
PROJECT: NAPASKIAK POWER SYSTEM UPGRADE			
TITLE: BUILDING SECTIONS & DETAILS			
DRAWN BY: JTD		SCALE: AS NOTED	
DESIGNED BY: DGT/BCG		DATE: 4/18/22	
FILE NAME: NAPS PP A1-A4		SHEET: A4	
PROJECT NUMBER: P.O. 111405, Anchorage, AK 99511 (907)349-0100			

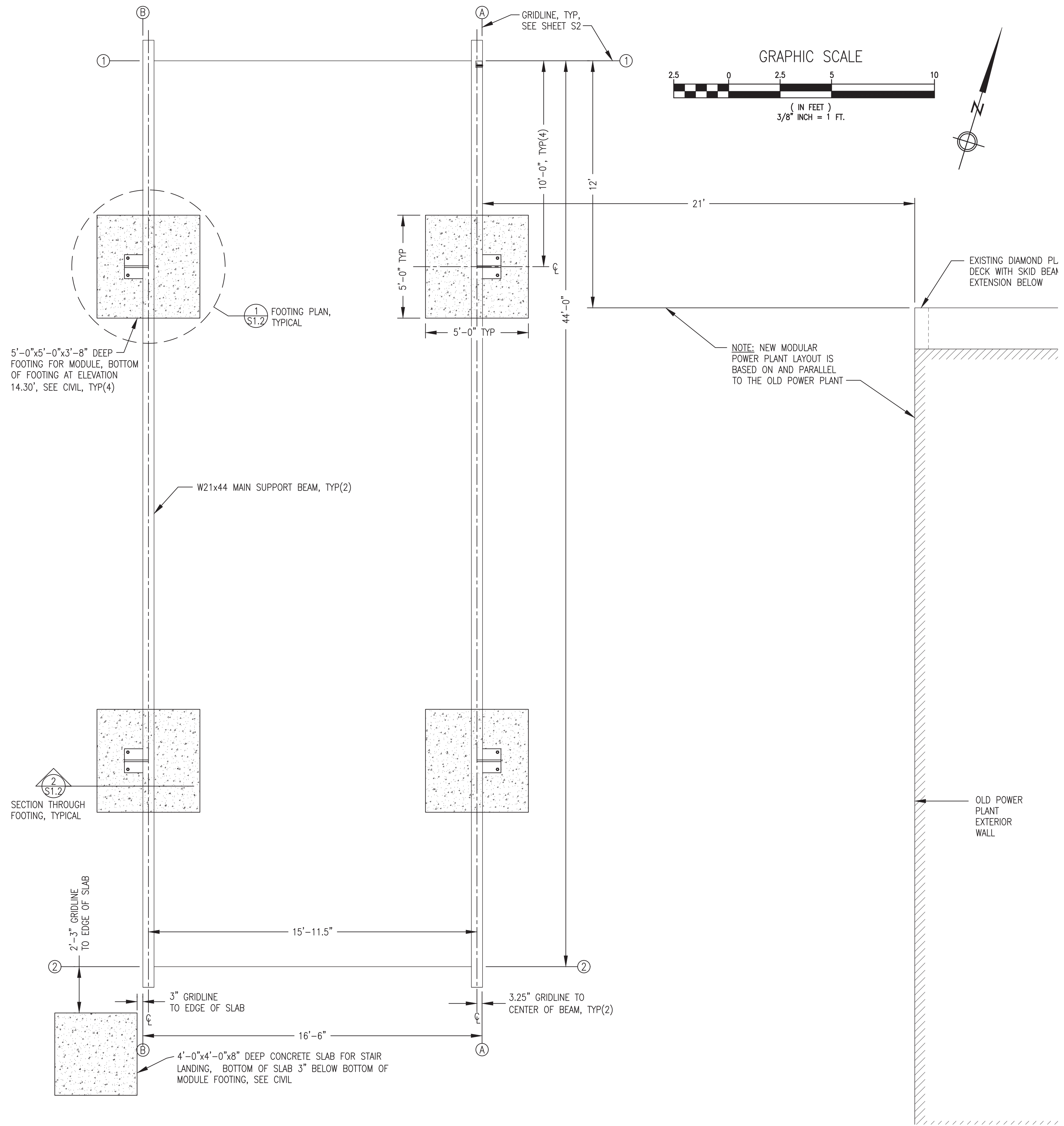

**STRUCTURAL GENERAL NOTES:**

1.0 DESIGN LOADS:

A. BUILDING CODE: 2021 INTERNATIONAL BUILDING CODE, ASCE 7-16

B. FLOOR LIVE LOADS: (IBC TABLE 1607.1)  
 LIGHT STORAGE/MANUFACTURING 125 PSF OR 2000 POUND POINT LOAD  
 MAXIMUM GENERATOR UNIT WEIGHT 7,000 POUNDS

C. SNOW LOADS: (ASCE 7-10)  
 GROUND SNOW LOAD,  $P_g =$  70 PSF  
 COEFFICIENT OF EXPOSURE,  $C_e =$  1.0 PARTIALLY EXPOSED  
 SNOW IMPORTANCE FACTOR,  $I_s =$  1.2 CATEGORY IV  
 THERMAL COEFFICIENT,  $C_t =$  1.2 COLD, VENTILATED ROOF  
 ROOF/FLAT SNOW LOAD,  $P_f =$  65 PSF

D. WIND LOADS:  
 BASIC WIND SPEED = 163 MPH, 3 SECOND GUST  
 RISK CATEGORY = CATEGORY IV  
 EXPOSURE CLASSIFICATION = EXPOSURE C

E. SEISMIC LOADING:  
 SEISMIC =  $S_s = 0.273$   $S_1 = 0.118$   
 SEISMIC IMPORTANCE FACTOR = 1.50, CATEGORY IV

SITE CLASS "D" (DEFAULT)  
 BASIC SEISMIC FORCE RESISTANCE SYSTEM  
 BUILDING = BEARING WALL WITH STEEL SHEAR PANELS  
 FOUNDATION = SPREAD CONCRETE FOOTINGS  
 SEISMIC RESPONSE COEFFICIENT  $R = 7.0$

**MODULE FOUNDATION SYSTEM SHOWN THIS SHEET IS INCLUDED IN THE ON SITE CONTRACT.**

2	REVISED TO INCLUDE ONSITE FOUNDATION DESIGN	11/1/22	BCG
1	REVISED FOR NEW ENGINE/GENERATOR SELECTION	6/6/22	BCG
REV.	DESCRIPTION	DATE	BY



PROJECT:		NAPASKIAK POWER SYSTEM UPGRADE	
TITLE:		CODE ANALYSIS, STRUCTURAL NOTES & FOUNDATION PLAN	
DESIGNED BY: DGT/BCG	SCALE: AS NOTED	DATE: 4/18/22	SHEET: S1.1
FILE NAME: NAPS PP S1-5	PROJECT NUMBER:		

**REV #2  
ISSUED FOR  
CONSTRUCTION  
NOV 2022**

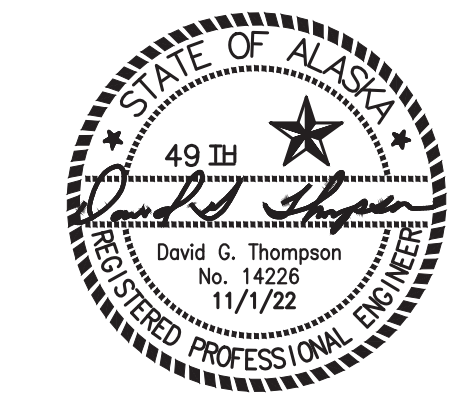

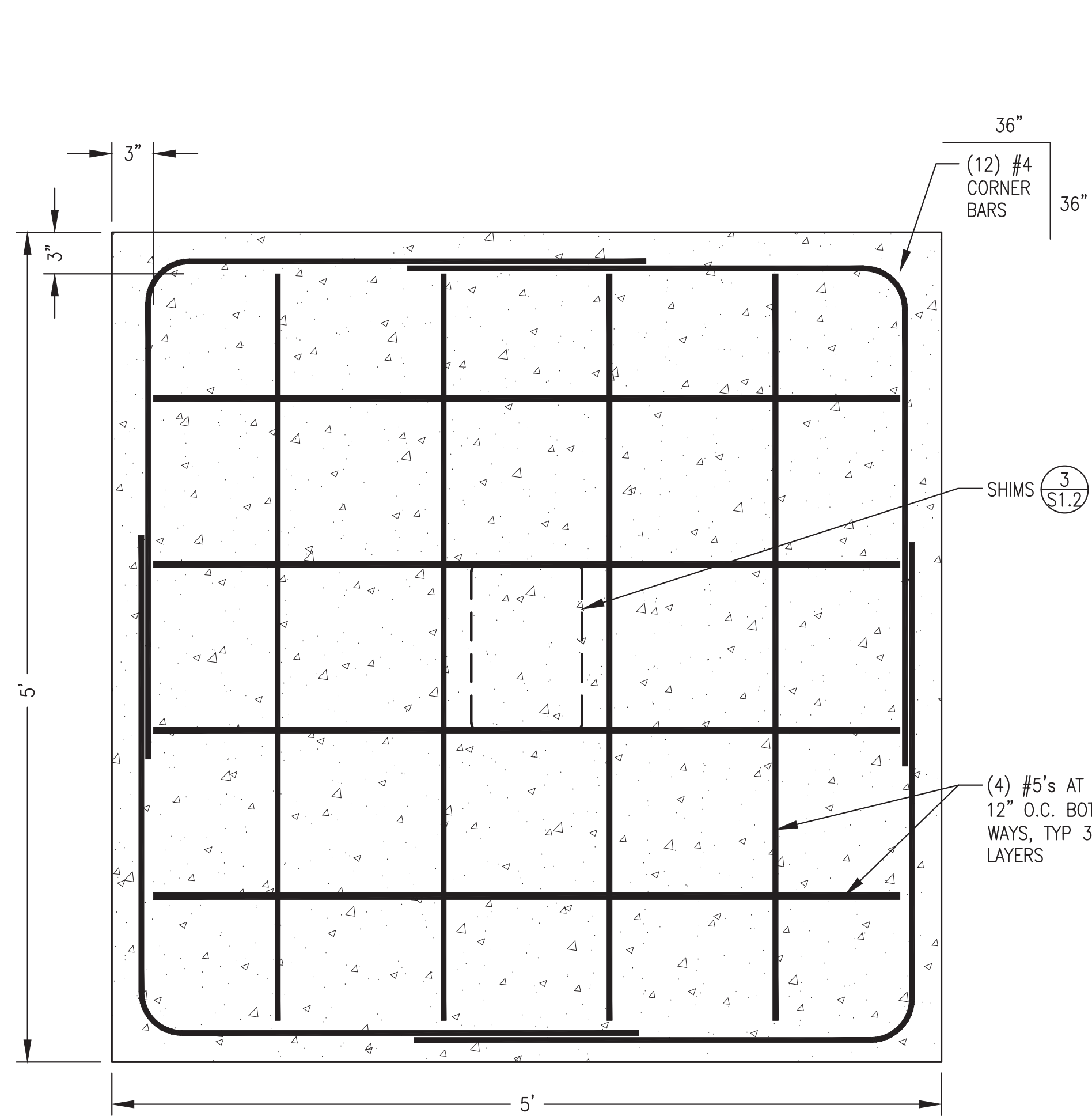

1 FOOTING PLAN  
S1.2 1 1/2'-1'-0"

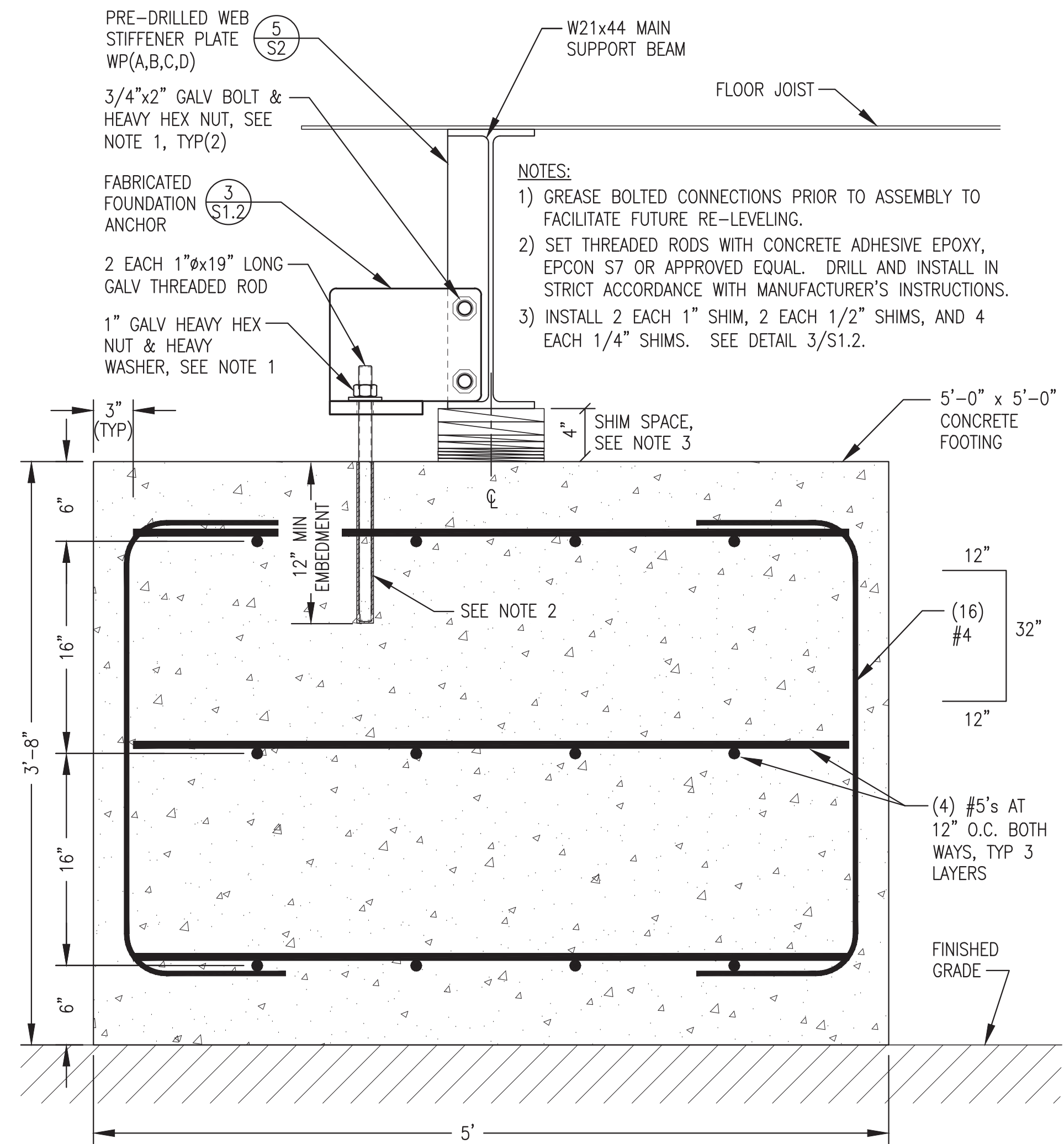

2 SECTION THROUGH FOOTING  
S1.2 1 1/2'-1'-0"

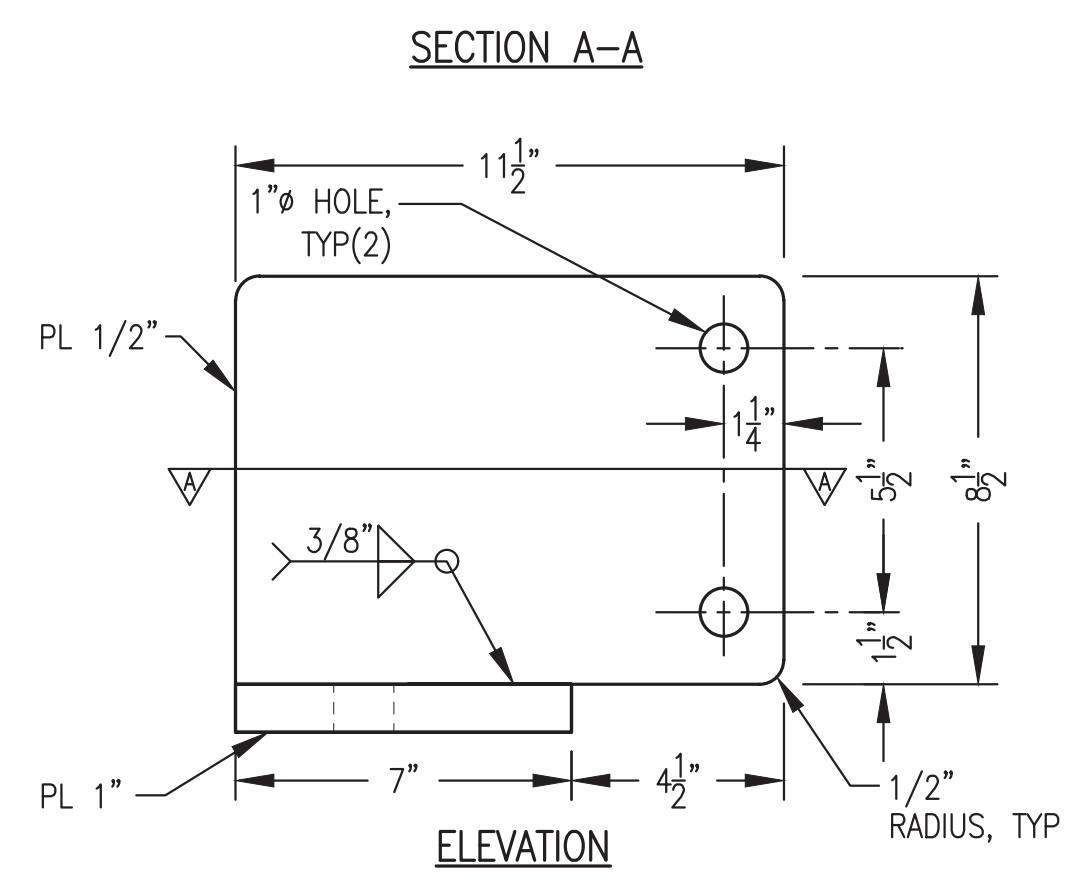
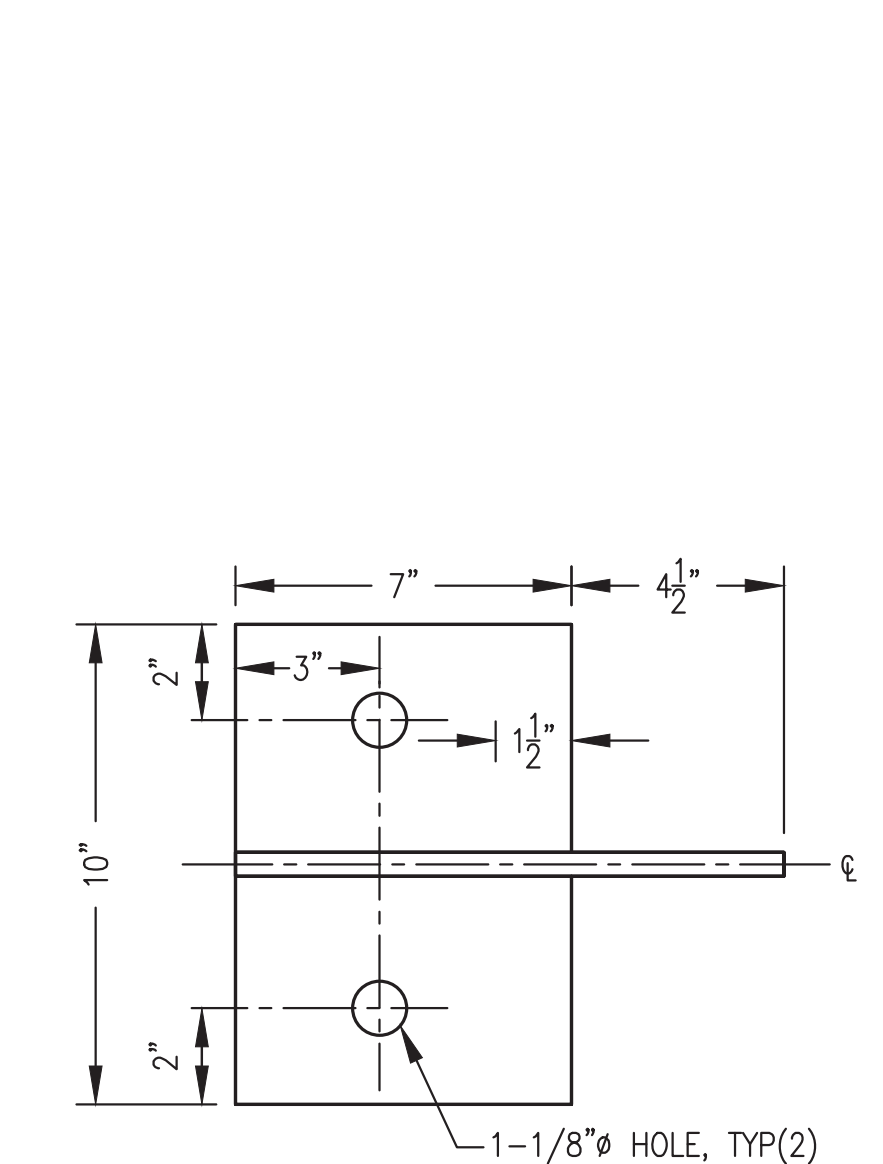

3 TYPICAL FOUNDATION ANCHOR & SHIM FABRICATION  
S1.2 3'-1'-0"

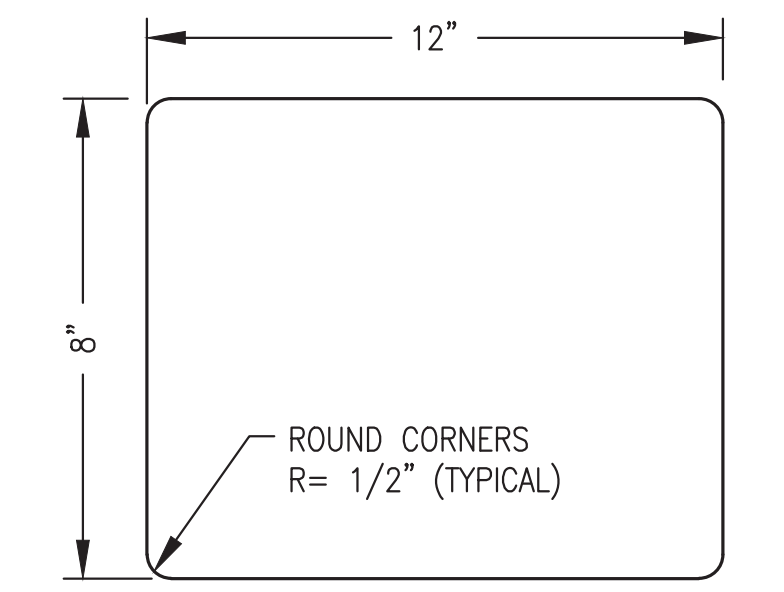

TYPICAL SHIM

SHIM FABRICATION TABLE		
THICKNESS	QUANTITY	MATERIAL
1/4"	16	GALV STEEL
1/2"	8	GALV STEEL
1"	8	GALV STEEL

- ANCHOR & SHIM FABRICATION NOTES:**
- 1) FABRICATE FOUR IDENTICAL ANCHOR ASSEMBLIES. DO NOT SHEAR ANCHOR PLATES. CUT WITH WATER JET, TORCH, OR SAW.
  - 2) FABRICATE FROM ASTM A-36 STEEL PLATE.
  - 3) MAKE ALL JOINTS AND CONNECTIONS WITH CONTINUOUS GROOVE OR FILLET WELDS.
  - 4) FABRICATE SHIMS OF QUANTITY AND THICKNESS AS DESCRIBED IN SHIM FABRICATION TABLE.
  - 5) UPON COMPLETION OF FABRICATION ROUND ALL OUTSIDE CORNERS AND GRIND ALL EDGES SMOOTH.
  - 6) SAND BLAST ALL PIECES TO SSPC-SP-6. COAT WITH 3 COATS OF COLD GALVANIZING COMPOUND, ZRC OR APPROVED EQUAL TO 9 MILS MINIMUM DRY FILM THICKNESS.

MODULE FOUNDATION SYSTEM SHOWN THIS SHEET IS INCLUDED IN THE ON SITE CONTRACT.

ISSUED FOR CONSTRUCTION  
NOV 2022

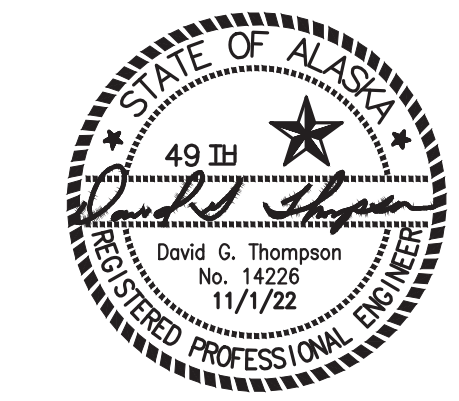

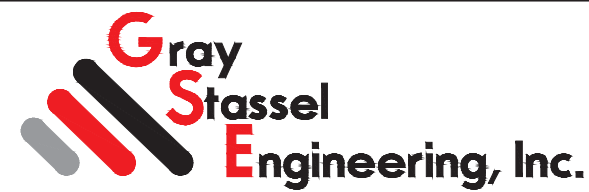
 ALASKA ENERGY AUTHORITY		
PROJECT: NAPASKIAK POWER SYSTEM UPGRADE		
TITLE: FOUNDATION DETAILS		
 Gray Stassel Engineering, Inc. P.O. 111405, Anchorage, AK 99511 (907)349-0100	DRAWN BY: JTD DESIGNED BY: DGT/BCG FILE NAME: NAPS PP S1-5 PROJECT NUMBER:	SCALE: AS NOTED DATE: 11/1/22 SHEET: S1.2

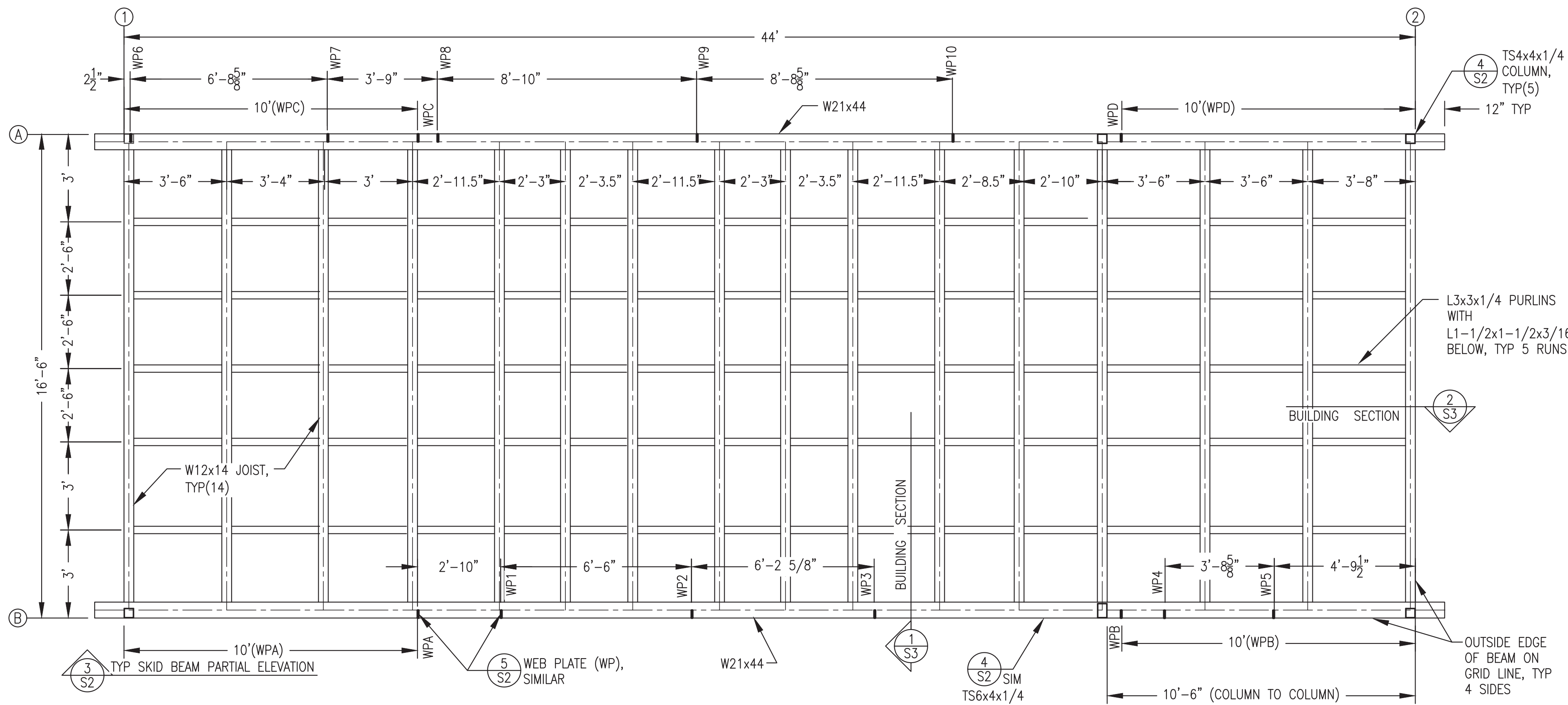

NOTES: 1) FABRICATE FLOOR AND PAN DECKS USING SHEETS CUT SO THAT ALL JOINTS ARE CENTERED ON PURLINS AND/OR JOISTS.  
2) SEE MECHANICAL SUPPORT PLAN M2.2 FOR GENERATOR SUPPORT PEDESTAL LOCATIONS AND FABRICATION.

**1 FLOOR FRAMING PLAN**  
S2 3/8"=1'-0"

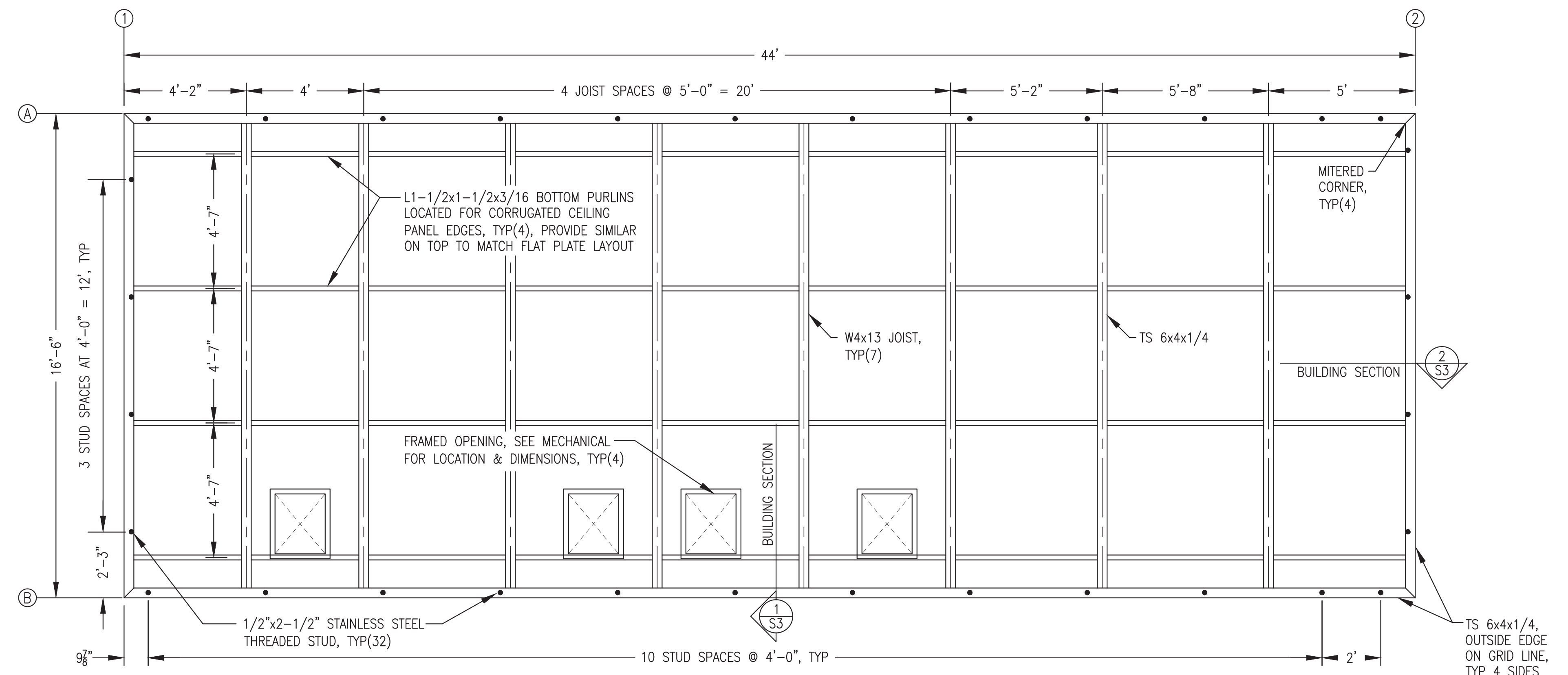

NOTES: 1) FABRICATE CEILING FLAT AND CORRUGATED DECKS USING SHEETS CUT SO THAT ALL JOINTS ARE CENTERED ON PURLINS AND/OR JOISTS.  
2) SEE MECHANICAL SUPPORT PLAN M2.3 FOR CEILING CORRUGATION LAYOUT AND STRUT SUPPORT LOCATION AND INSTALLATION.  
3) PROVIDE ADDITIONAL L1-1/2" BOTTOM PURLINS AGAINST PERIMETER TS AS REQUIRED FOR CORRUGATED CEILING SUPPORT.

**2 CEILING FRAMING PLAN**  
S2 3/8"=1'-0"

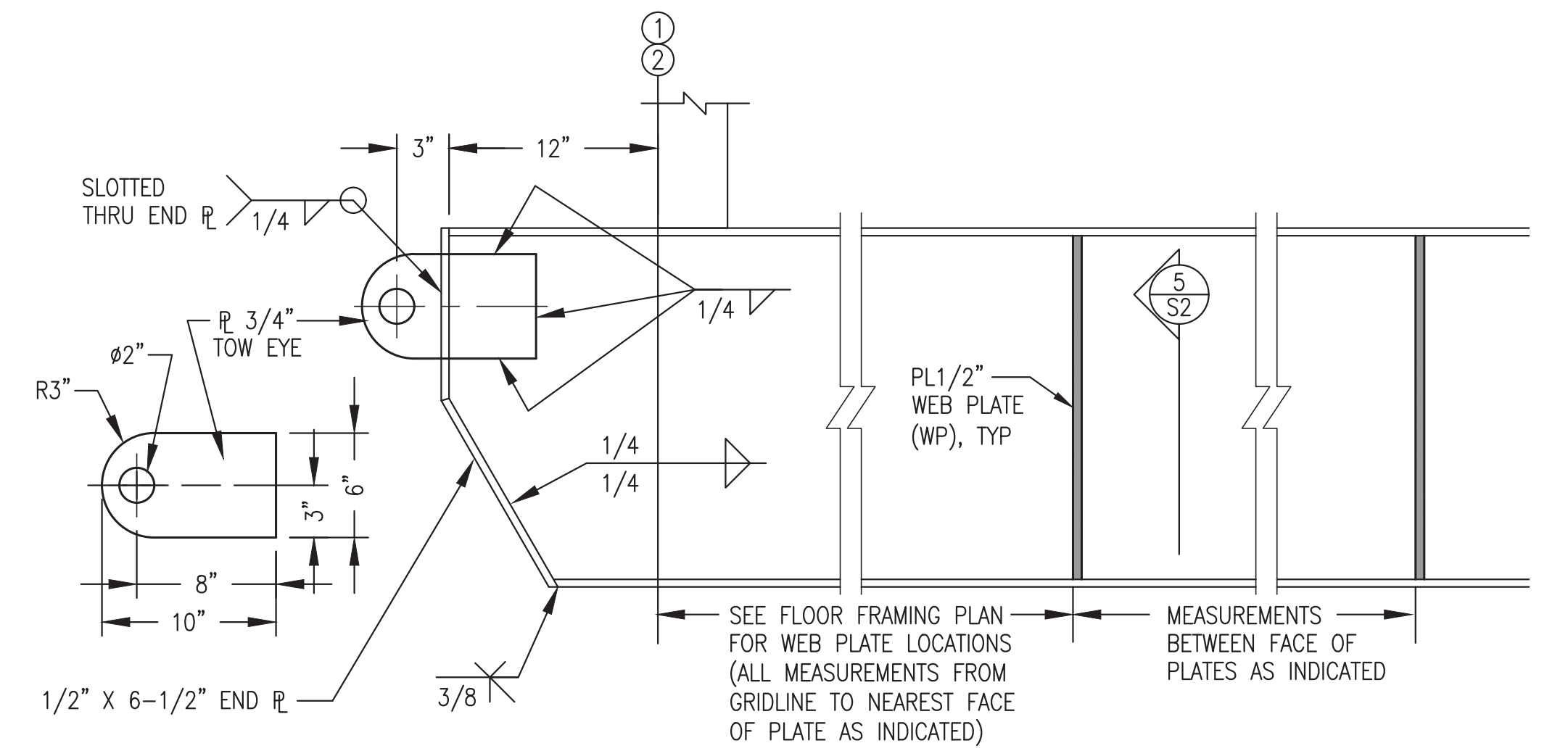

**3 TYPICAL SKID BEAM PARTIAL ELEVATION**  
S2 1-1/2"=1'-0"

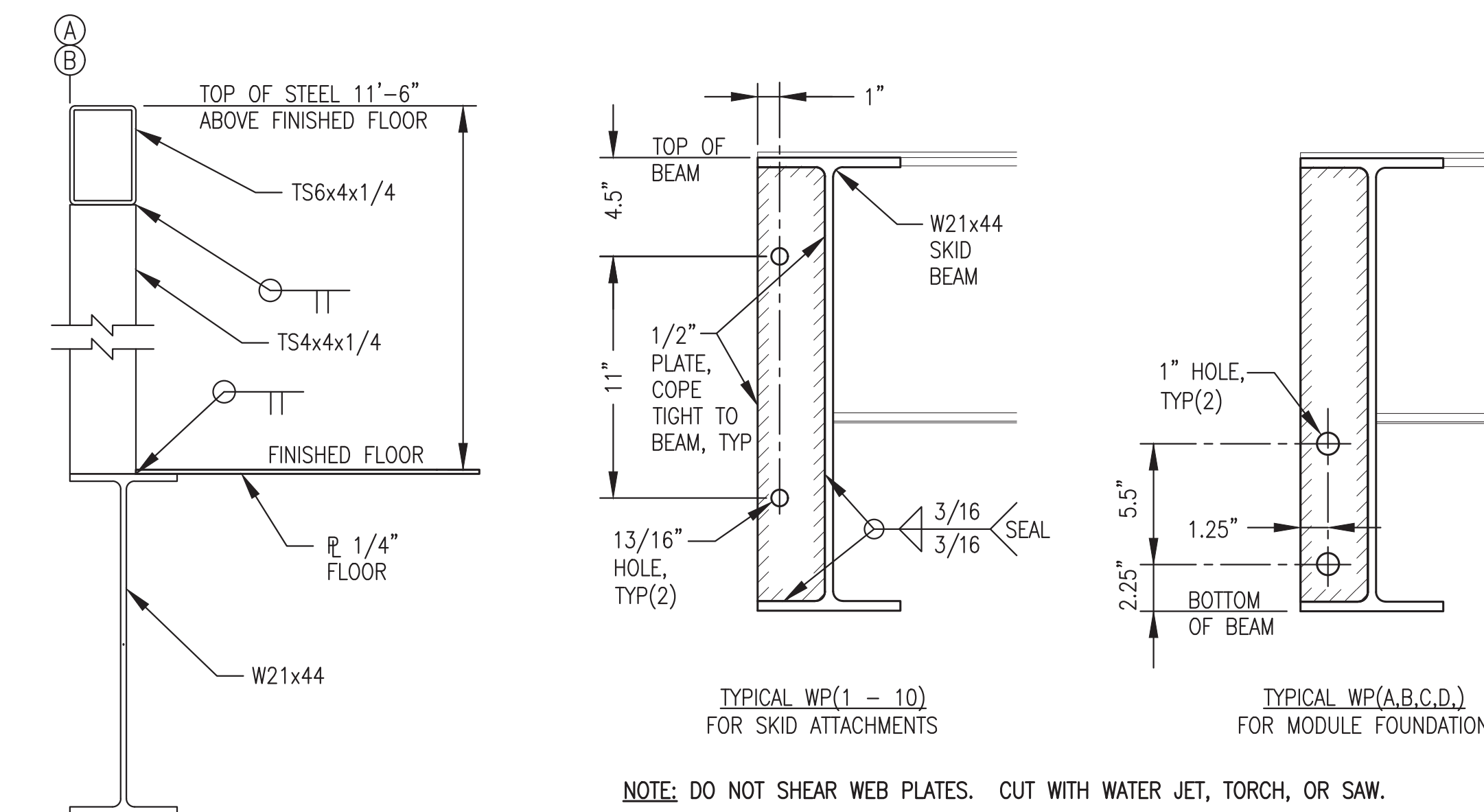

**4 TYP CORNER COLUMN**  
S2 1-1/2"=1'-0"

**5 WEB PLATE (WP) FABRICATION**  
S2 2"=1'-0"

ALL WORK ON THIS SHEET WAS PERFORMED AS PART OF THE PRIOR MODULE FABRICATION CONTRACT AND IS SHOWN HERE FOR REFERENCE ONLY.

1	REVISED FOR NEW ENGINE/GENERATOR SELECTION	6/6/22	BCG
REV.	DESCRIPTION	DATE	BY
 ALASKA ENERGY AUTHORITY			
PROJECT: NAPASKIAK POWER SYSTEM UPGRADE			
TITLE: MODULE FRAMING PLANS & DETAILS			
DRAWN BY: JTD		SCALE: AS NOTED	
DESIGNED BY: DGT/BCG		DATE: 4/18/22	
FILE NAME: NAPS PP S1-5		SHEET: S2	
PROJECT NUMBER:			
P.O. 111405, Anchorage, AK 99511 (907)349-0100			

REV#1 ISSUED  
JUNE 2022



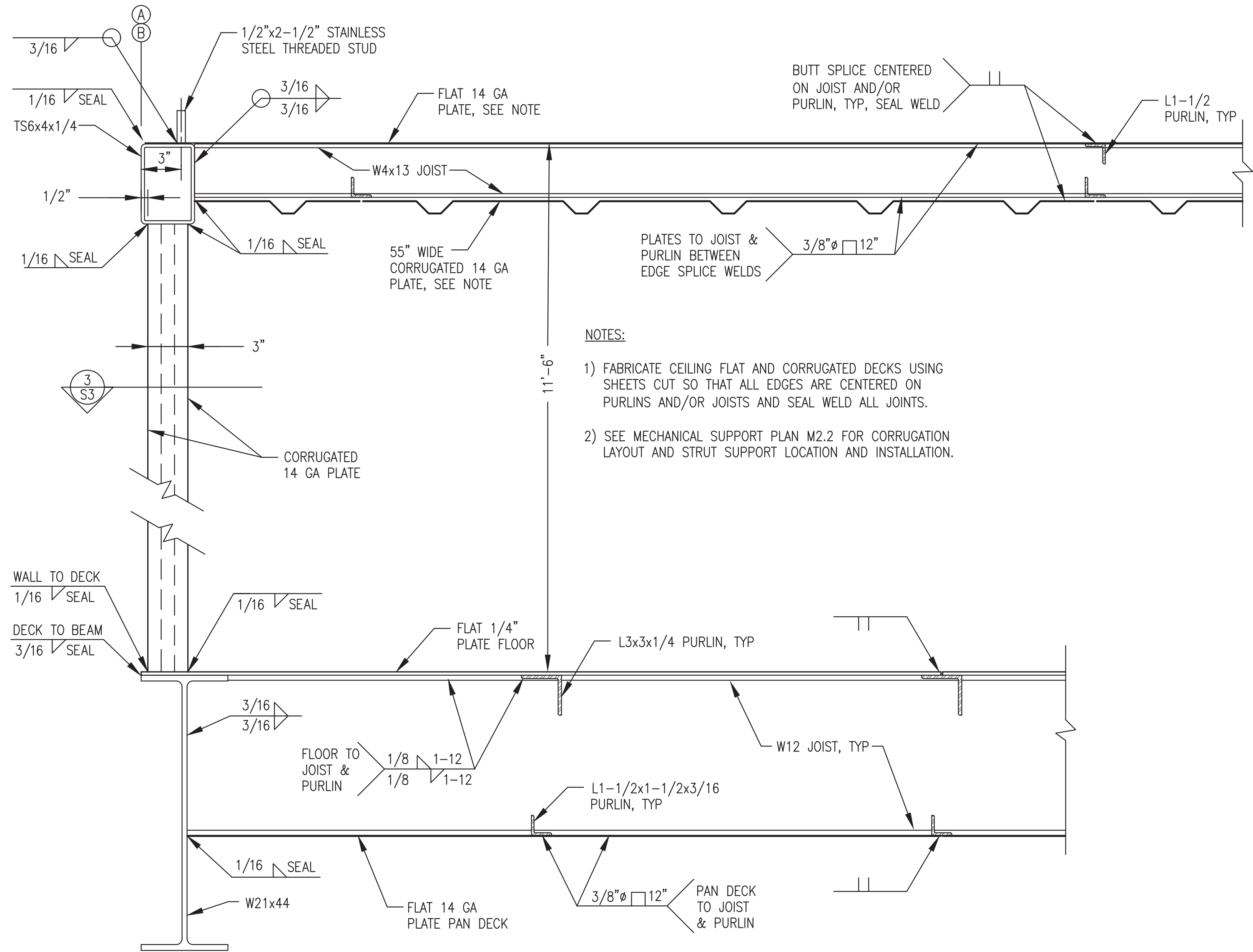

- NOTES:
- 1) FABRICATE CEILING FLAT AND CORRUGATED DECKS USING SHEETS CUT SO THAT ALL EDGES ARE CENTERED ON PURLINS AND/OR JOISTS AND SEAL WELD ALL JOINTS.
  - 2) SEE MECHANICAL SUPPORT PLAN M2.2 FOR CORRUGATION LAYOUT AND STRUT SUPPORT LOCATION AND INSTALLATION.

1 TYPICAL BUILDING SECTION  
S3 2"=1'-0"

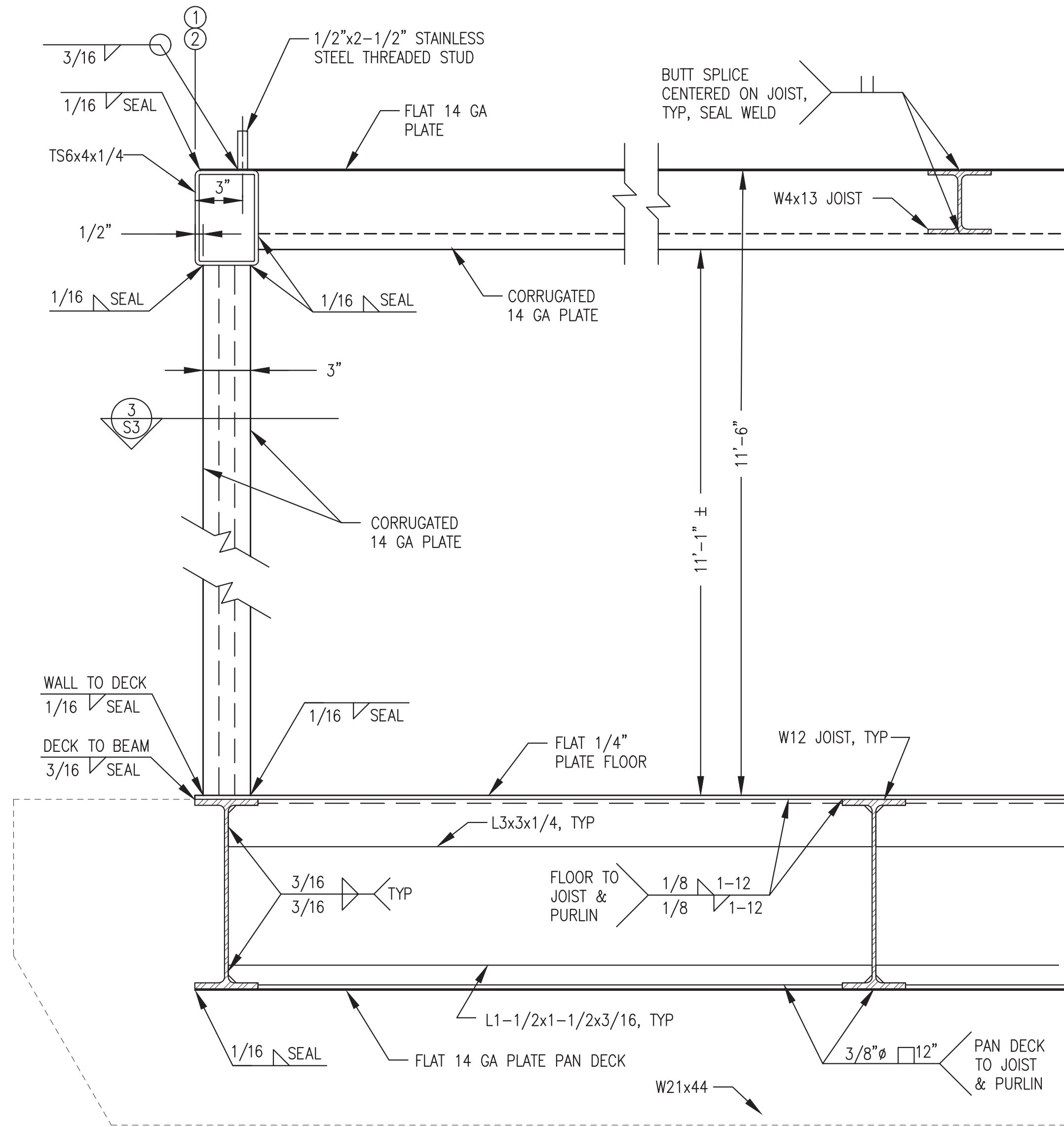

2 TYPICAL BUILDING SECTION  
S3 2"=1'-0"

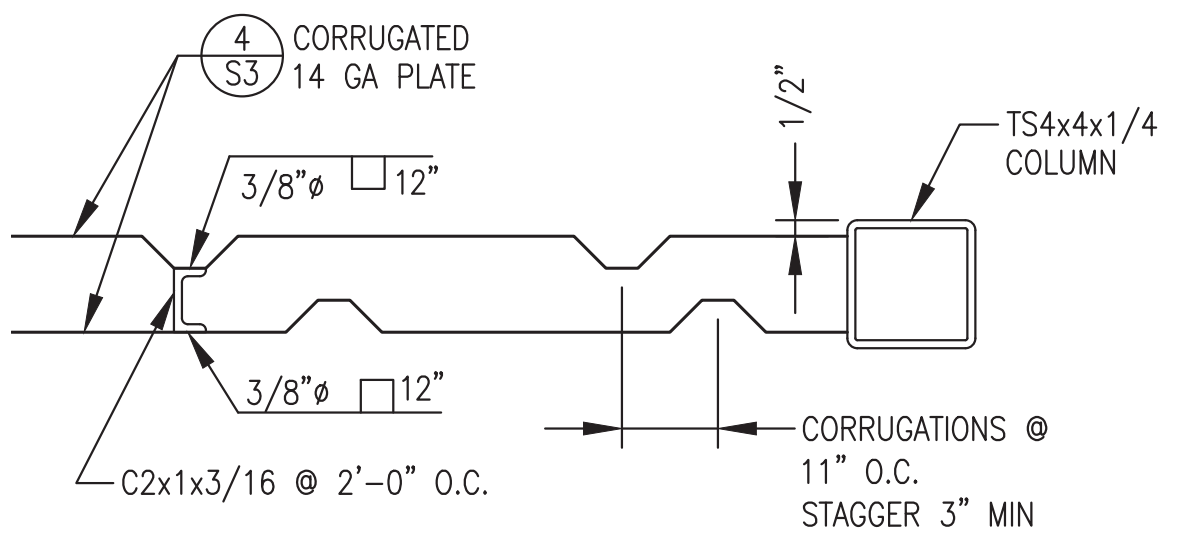

3 TYPICAL EXTERIOR WALL - PLAN VIEW  
S3 2"=1'-0"

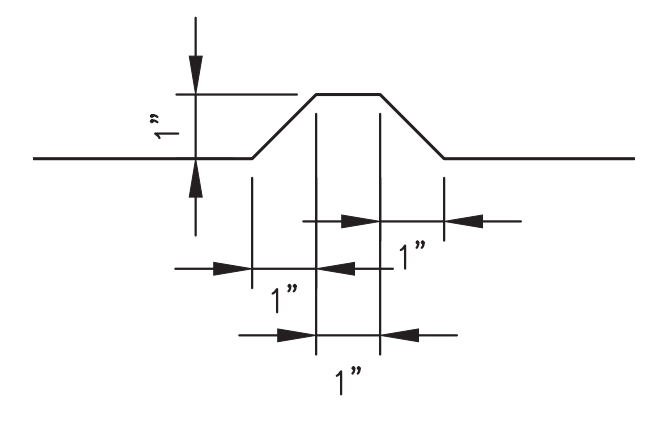

4 TYPICAL CORRUGATION  
S3 4"=1'-0"

ALL WORK ON THIS SHEET WAS PERFORMED AS PART OF THE PRIOR MODULE FABRICATION CONTRACT AND IS SHOWN HERE FOR REFERENCE ONLY.

1	REVISED FOR NEW ENGINE/GENERATOR SELECTION	6/6/22	BCG
REV.	DESCRIPTION	DATE	BY
 ALASKA ENERGY AUTHORITY			
PROJECT: NAPASKIAK POWER SYSTEM UPGRADE			
TITLE: MODULE SECTIONS DETAILS			
DRAWN BY: JTD		SCALE: AS NOTED	
DESIGNED BY: DGT/BCG		DATE: 4/18/22	
FILE NAME: NAPS PP S1-5		SHEET: S3	
PROJECT NUMBER:			

REV#1 ISSUED  
JUNE 2022

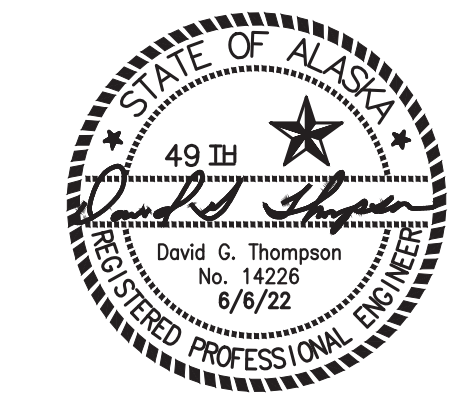

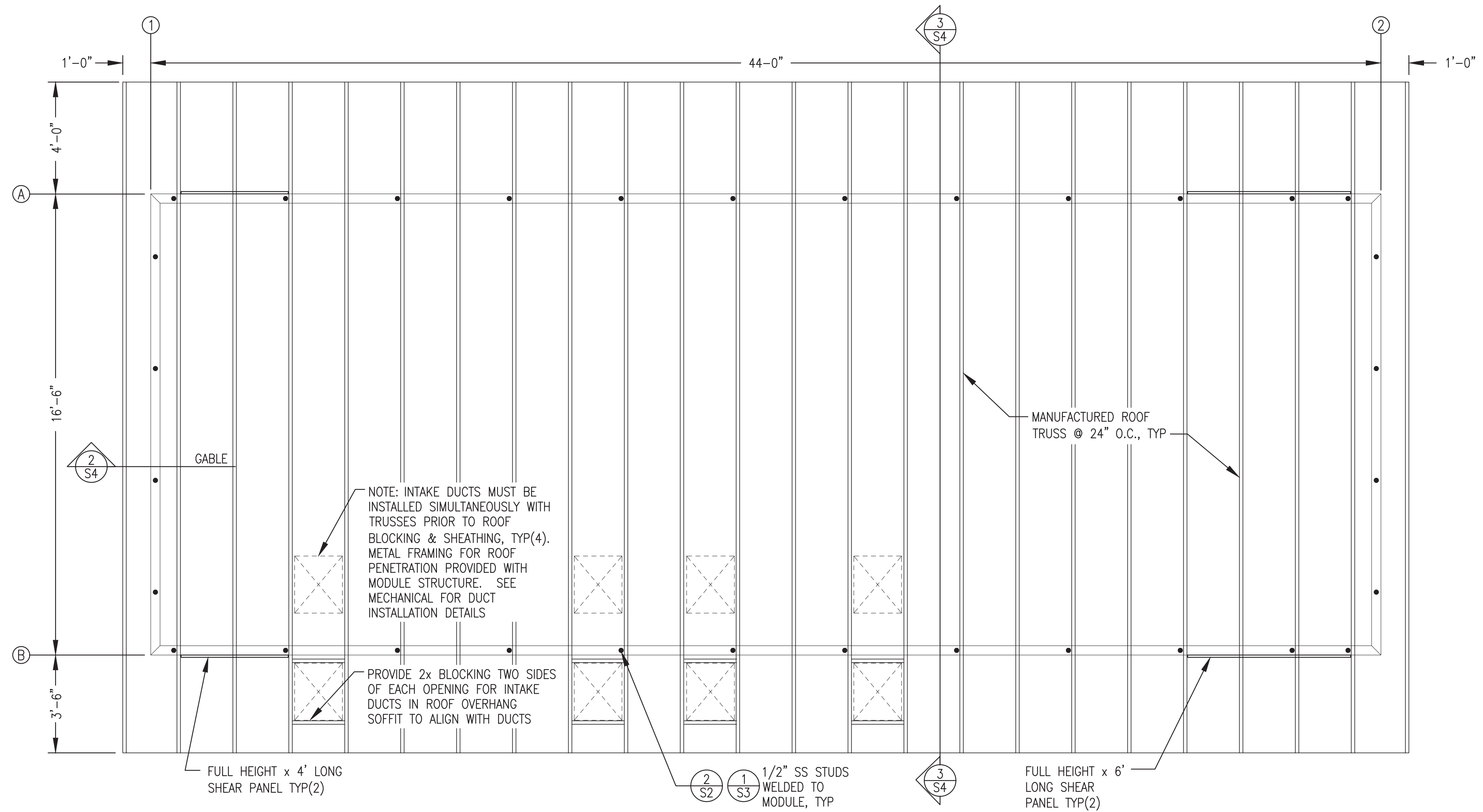

**1**  
S4  
ROOF FRAMING PLAN  
3/8"=1'-0"

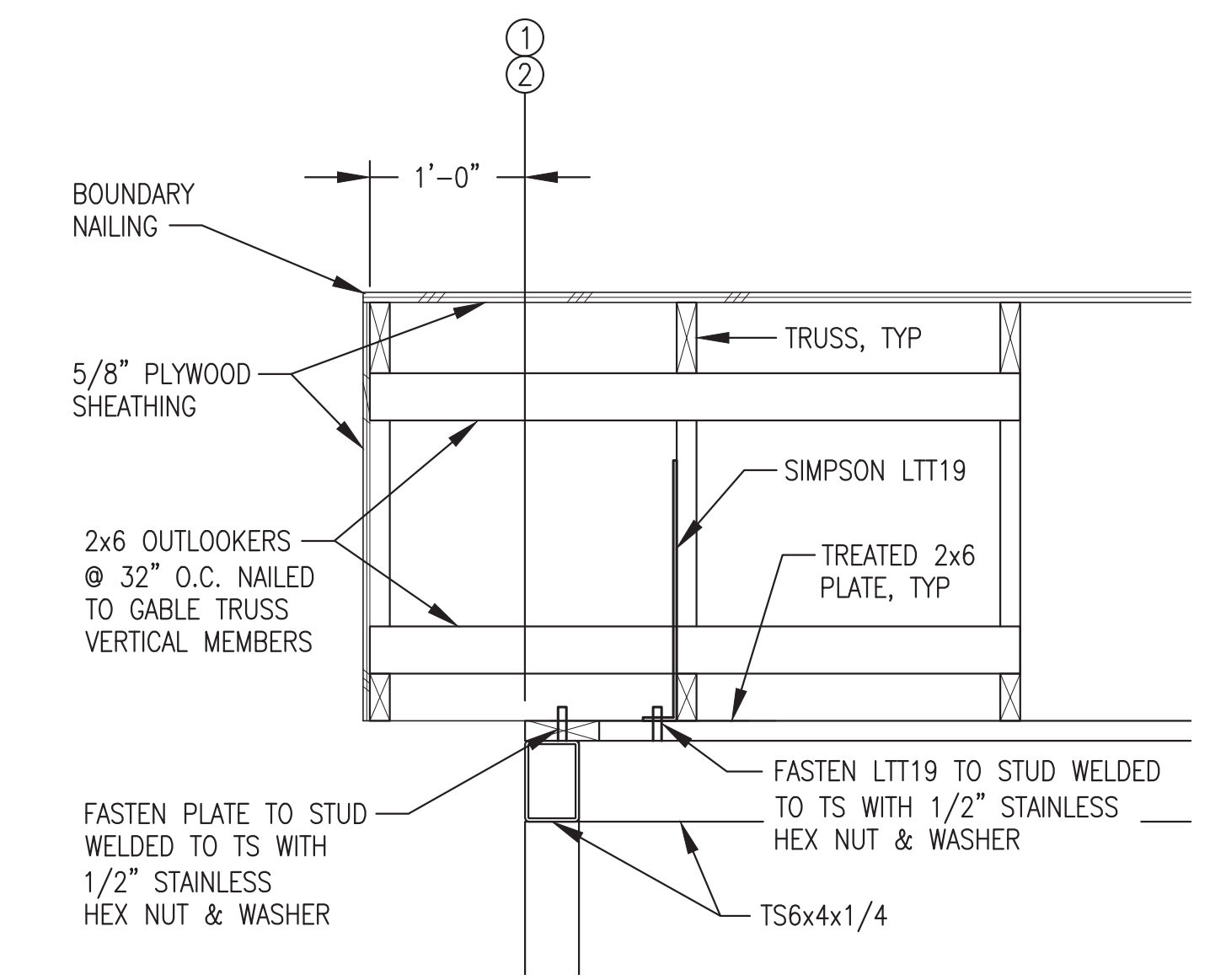

**2**  
S4  
TYPICAL GABLE  
1"=1'-0"

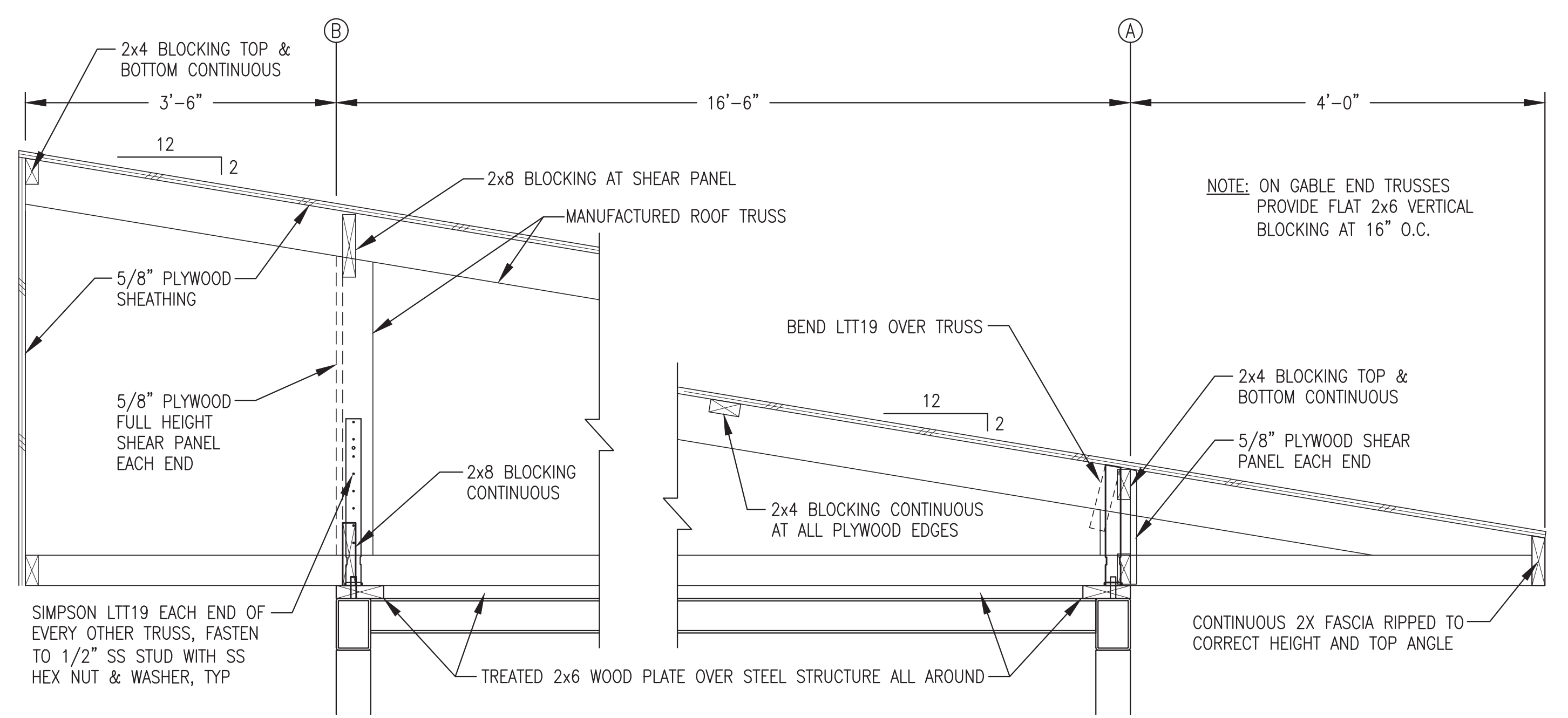

**3**  
S4  
ROOF TRUSS INSTALLATION  
NO SCALE

STAINLESS STEEL STUDS WERE WELDED TO THE MODULE AS PART OF THE PRIOR MODULE FABRICATION CONTRACT. ALL OTHER WORK THIS SHEET IS INCLUDED IN THE ON SITE SCOPE.

REV.	DESCRIPTION	DATE	BY
2	REVISED FOR INTAKE DUCT INSTALLATION NOTES	7/15/22	BCG
1	REVISED FOR NEW ENGINE/GENERATOR SELECTION	6/6/22	BCG

**ALASKA ENERGY AUTHORITY**

PROJECT: **NAPASKIAK POWER SYSTEM UPGRADE**

TITLE: **ROOF FRAMING PLAN & DETAILS**

DRAWN BY: JTD	SCALE: AS NOTED
DESIGNED BY: DGT/BCG	DATE: 4/18/22
FILE NAME: NAPS PP S1-5	SHEET: <b>S4</b>
PROJECT NUMBER:	

P.O. 111405, Anchorage, AK 99511 (907)349-0100

REVISION #2  
ISSUED JULY  
2022

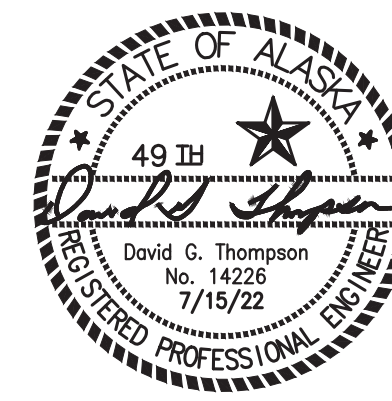

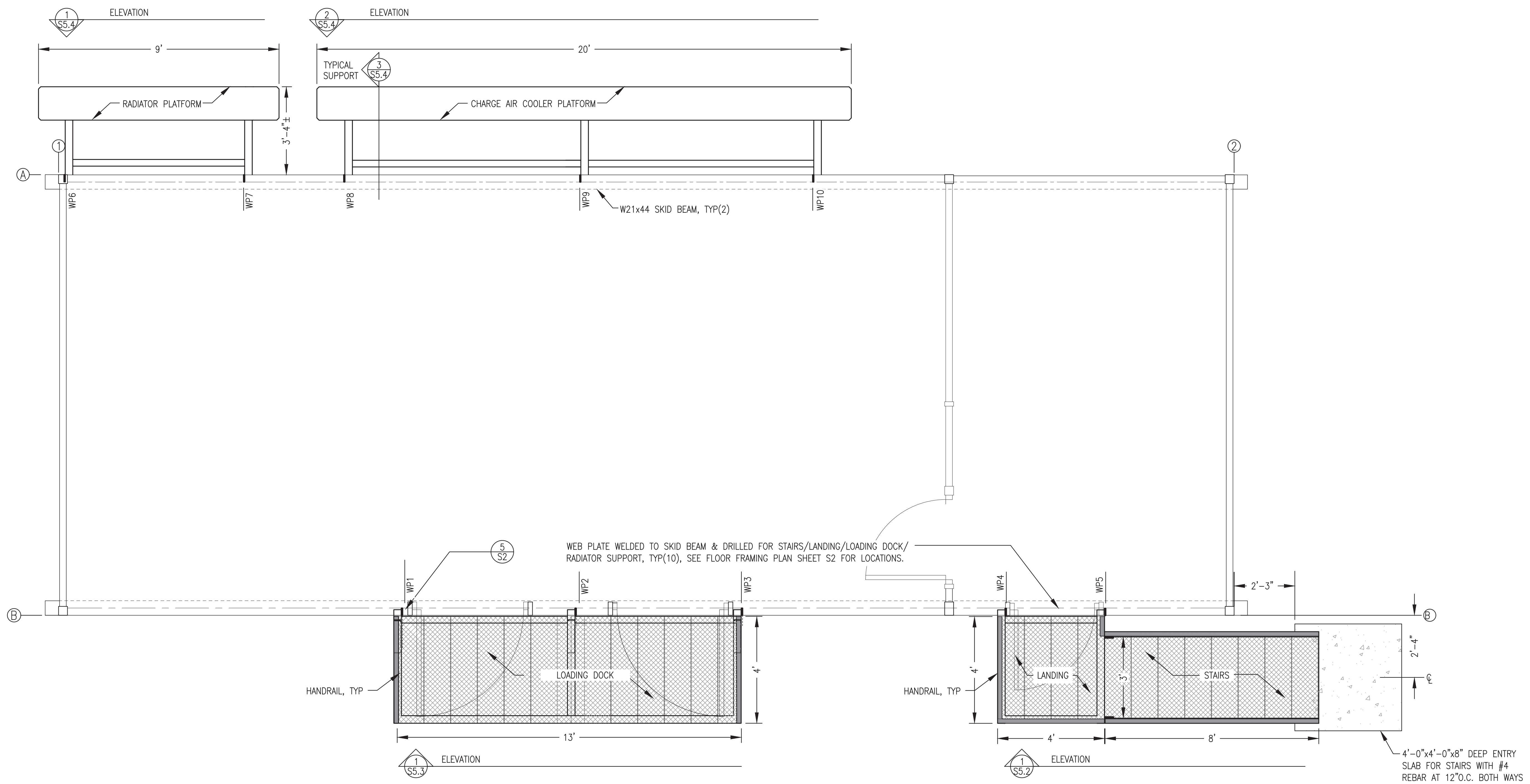

**1** STAIRS, LANDINGS, LOADING DOCK & RADIATOR SUPPORT PLAN  
**S5.1** 1/2"=1'-0"

**ALL EXTERIOR ASSEMBLIES THIS SHEET WERE FABRICATED AS PART OF THE PRIOR MODULE FABRICATION. CONCRETE SLAB AND FINAL INSTALLATION OF EXTERIOR ASSEMBLIES IS INCLUDED IN THE ON SITE SCOPE.**

- EXTERIOR ASSEMBLY FABRICATION GENERAL NOTES:**
- 1) THESE NOTES APPLY TO THE SHOP FABRICATION OF ALL EXTERIOR ASSEMBLIES SHOWN ON THE S5 SHEETS INCLUDING STAIRS, LANDINGS, LOADING DOCK, & RADIATOR SUPPORT.
  - 2) FABRICATE FROM ASTM A-36 STEEL SHAPES AND PLATE. STAIR AND PLATFORM TREADS TO BE PRE-GALVANIZED 2"x11-3/4"x12 GA. GRIP STRUT.
  - 3) RACK ALL SUPPORT BRACKETS LEVEL & PERPENDICULAR TO SKID WITH CONNECTIONS BOLTED TIGHT PRIOR TO WELDING.
  - 4) MAKE ALL JOINTS WITH CONTINUOUS GROOVE OR FILLET WELDS.
  - 5) SANDBLAST OR WIRE BRUSH ENDS OF PRE-GALV TREADS PRIOR TO WELDING TREADS TO STRUCTURE.
  - 6) UPON COMPLETION OF WELDING ROUND CORNERS AND GRIND EDGES SMOOTH.
  - 7) SANDBLAST ALL FABRICATIONS EXCEPT PRE-GALVANIZED GRIP STRUT TO SSPC-SP-6 AND APPLY 3 COATS OF COLD GALVANIZING COMPOUND, ZRC OR EQUAL.
  - 8) FURNISH GALVANIZED STEEL NUTS, BOLTS, AND WASHERS FOR FIELD ASSEMBLY.

REVISION #1  
 ISSUED JUNE  
 2022

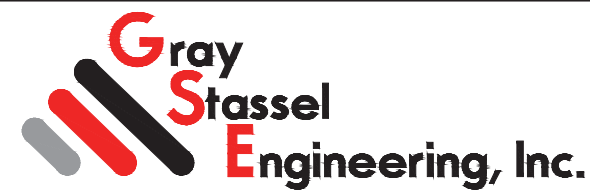

1	REVISED FOR NEW ENGINE/GENERATOR SELECTION	6/6/22	BCG
REV.	DESCRIPTION	DATE	BY
 ALASKA ENERGY AUTHORITY			
PROJECT: NAPASKIAK POWER SYSTEM UPGRADE			
TITLE: STAIRS, LANDINGS, LOADING DOCK, & RADIATOR SUPPORT PLAN			
 Gray Stassel Engineering, Inc. P.O. 111405, Anchorage, AK 99511 (907)349-0100		DRAWN BY: JTD DESIGNED BY: DGT/BCG FILE NAME: NAPS PP S1-5 PROJECT NUMBER:	SCALE: AS NOTED DATE: 4/18/22 SHEET: <b>S5.1</b>

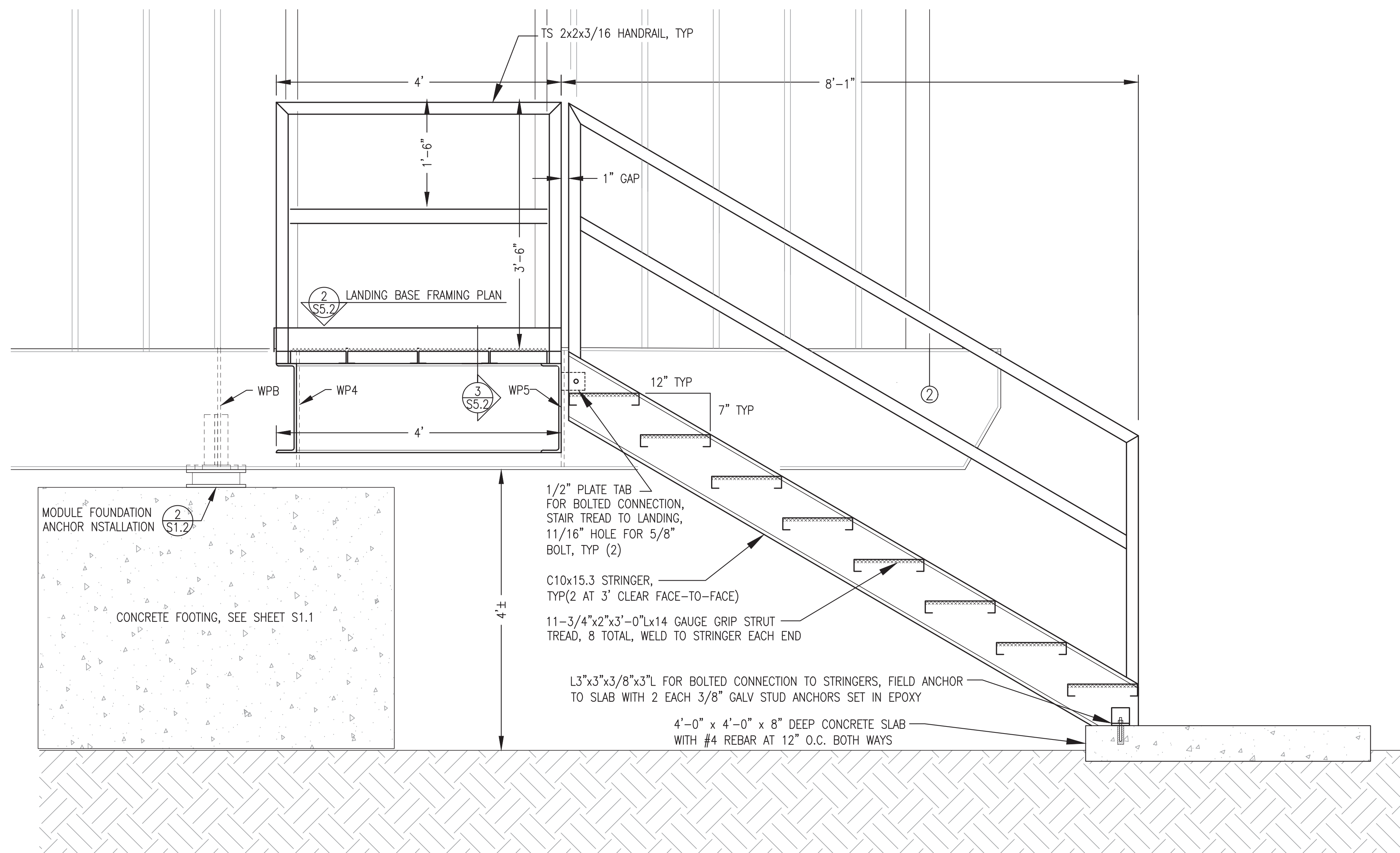

1 STAIR/LANDING ELEVATION  
S5.2 1"=1'-0"

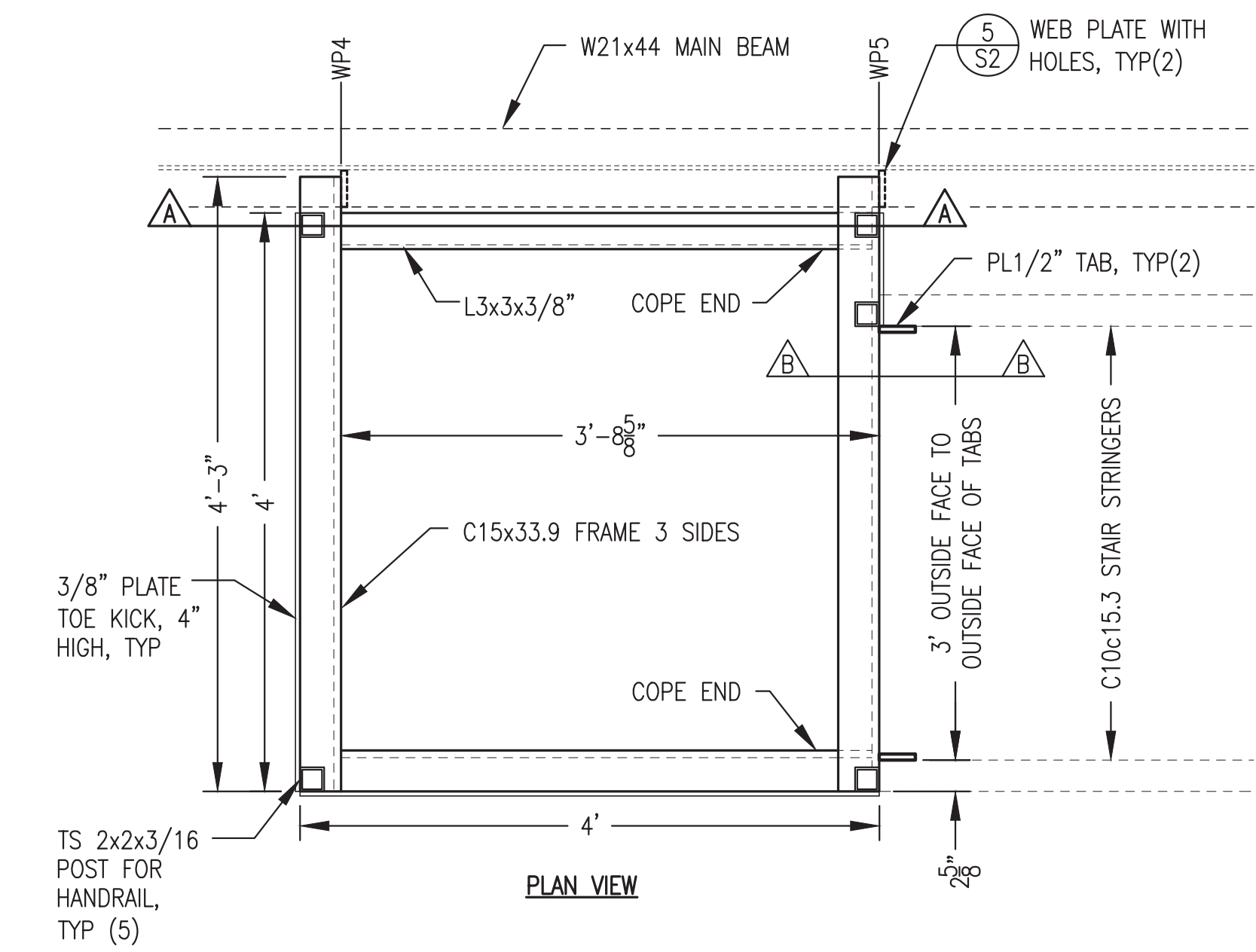

2 LANDING BASE FRAMING PLAN & SECTIONS  
S5.2 1"=1'-0"

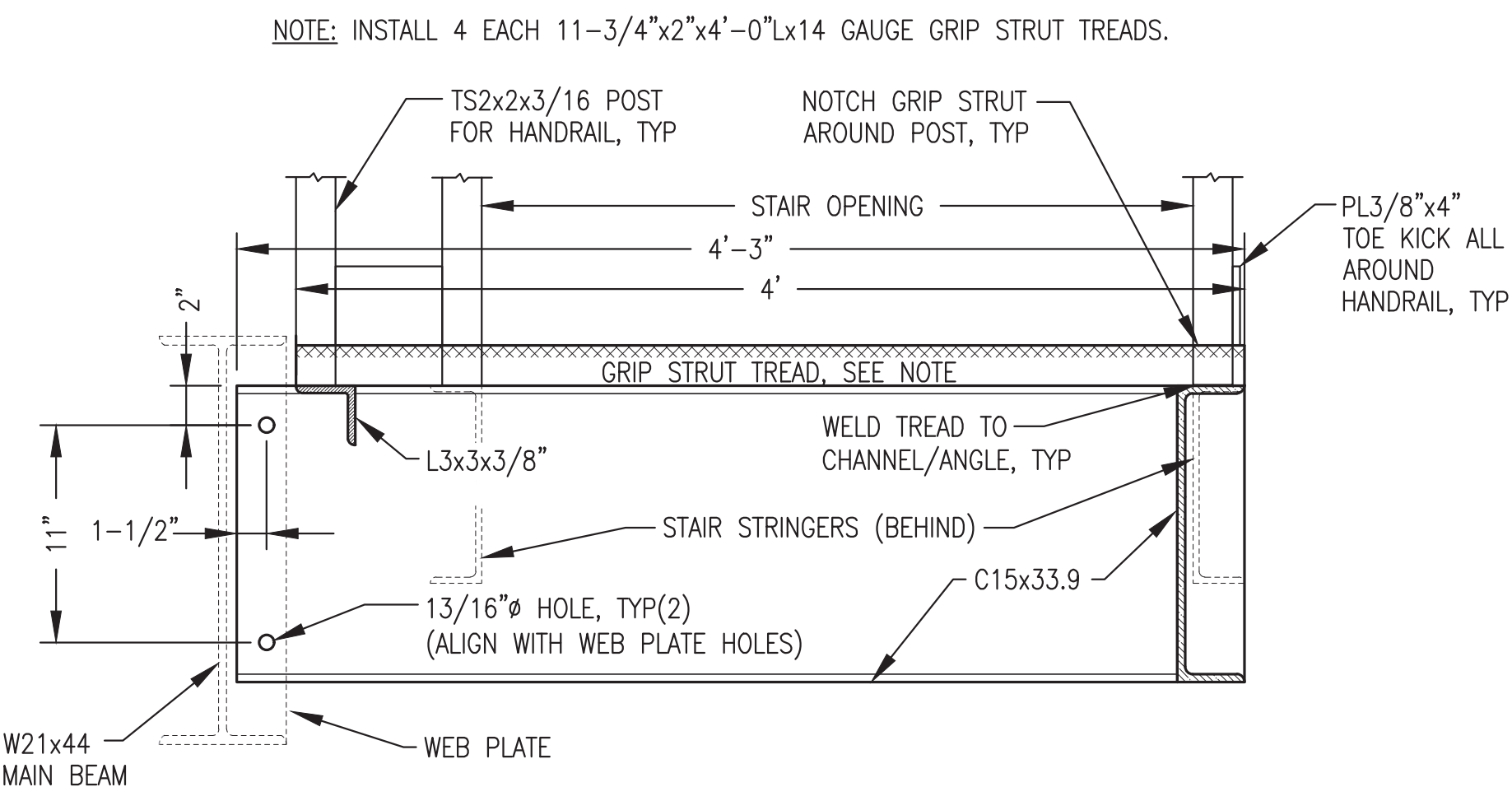

3 LANDING SECTION & MAIN BEAM CONNECTION DETAIL  
S5.2 1-1/2"=1'-0"

ALL EXTERIOR ASSEMBLIES THIS SHEET WERE FABRICATED AS PART OF THE PRIOR MODULE FABRICATION. CONCRETE SLAB AND FINAL INSTALLATION OF EXTERIOR ASSEMBLIES IS INCLUDED IN THE ON SITE SCOPE.

REVISION #1  
ISSUED JUNE  
2022

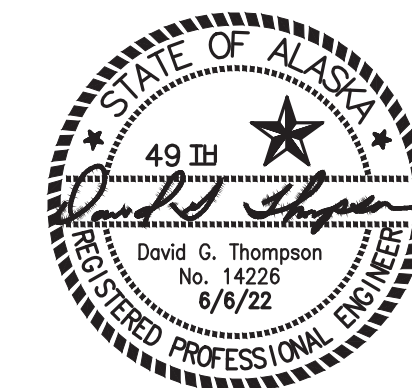

REV.	DESCRIPTION	DATE	BY
1	REVISED FOR NEW ENGINE/GENERATOR SELECTION	6/6/22	BCG

PROJECT: NAPASKIAK POWER SYSTEM UPGRADE

TITLE: STAIRS/LANDINGS FABRICATION DETAILS

DRAWN BY: JTD  
DESIGNED BY: DGT/BCG  
FILE NAME: NAPS PP S1-5  
PROJECT NUMBER:

SCALE: AS NOTED  
DATE: 4/18/22  
SHEET: S5.2

Gray Stassel Engineering, Inc.  
P.O. 111405, Anchorage, AK 99511 (907)349-0100

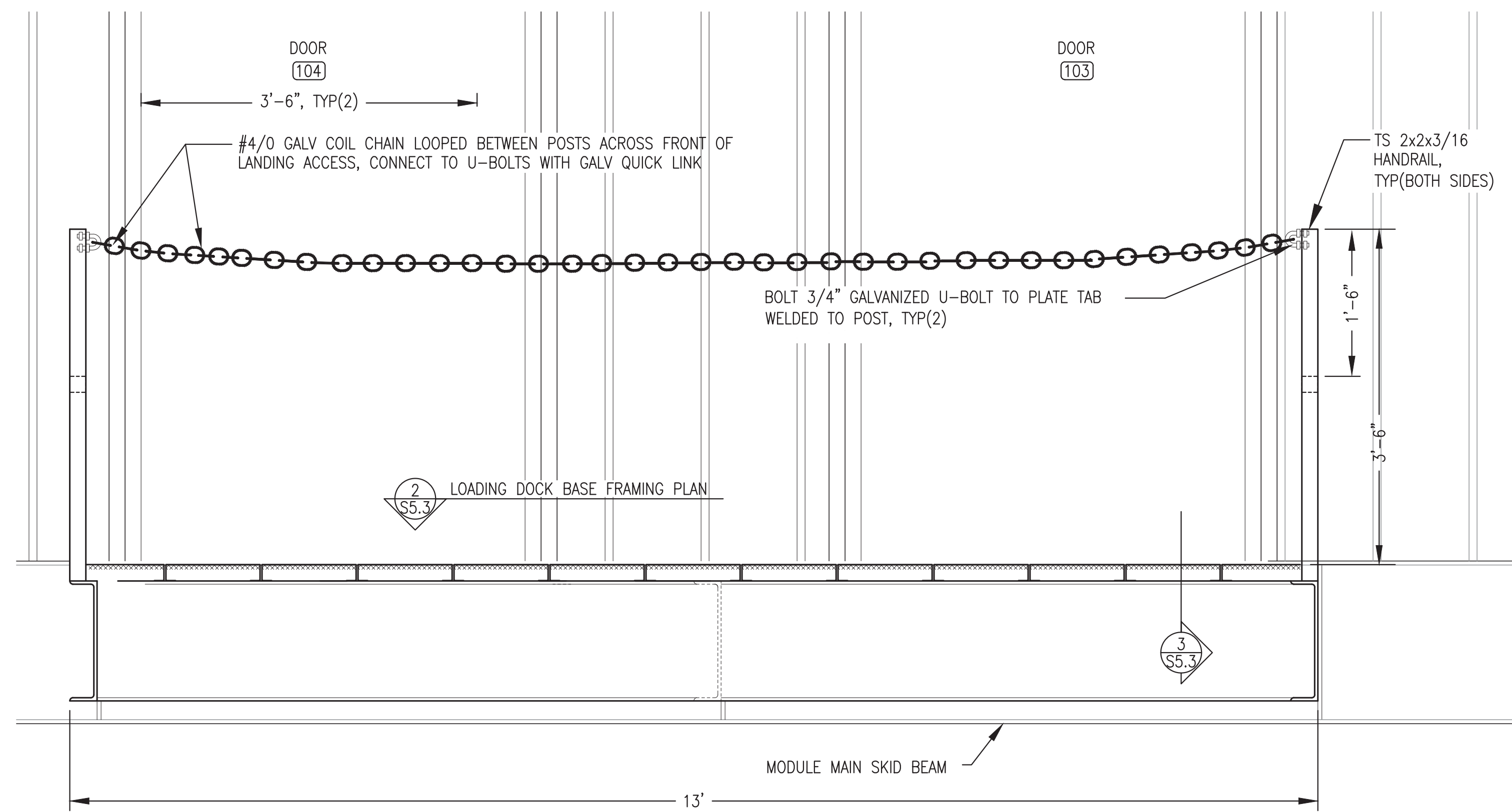

1 LOADING DOCK ELEVATION  
S5.3 1"=1'-0"

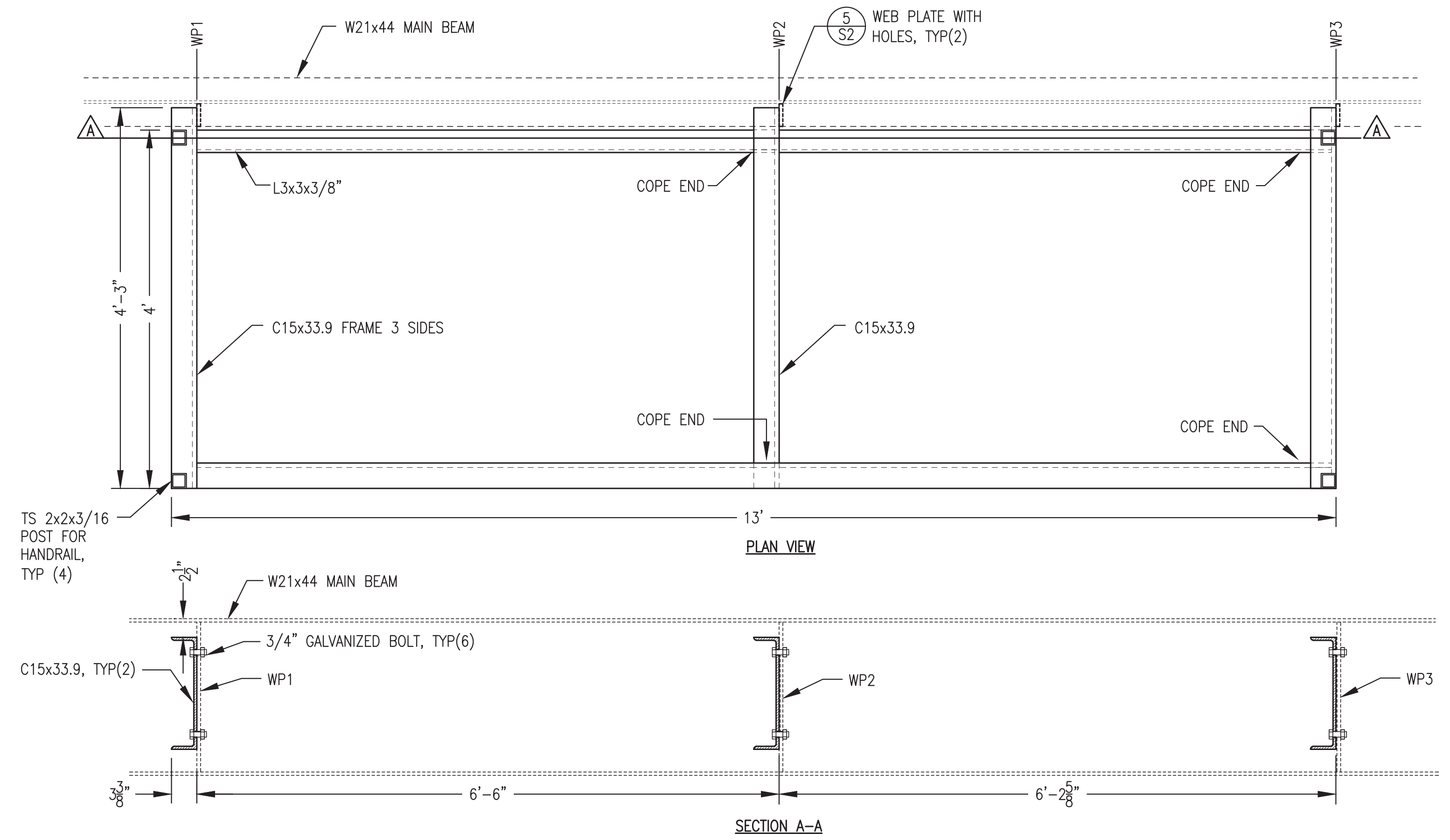

2 LOADING DOCK BASE FRAMING PLAN & SECTION  
S5.3 1"=1'-0"

NOTE: INSTALL 11 EACH 11-3/4"x2"x4'-0"Lx14 GAUGE GRIP STRUT TREADS.

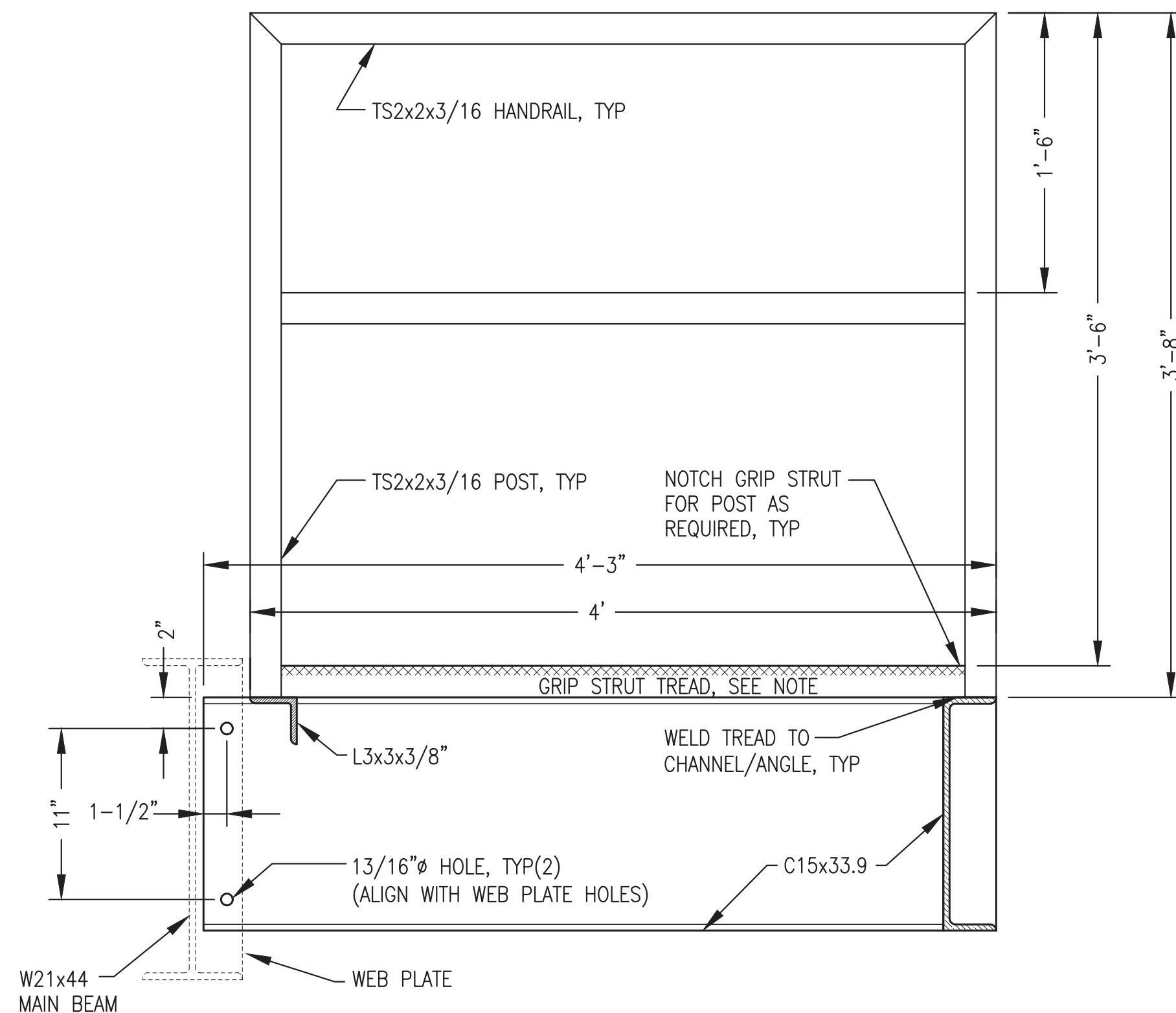

3 LOADING DOCK SECTION & MAIN BEAM CONNECTION DETAIL  
S5.3 1-1/2"=1'-0"

ALL EXTERIOR ASSEMBLIES THIS SHEET WERE FABRICATED AS PART OF THE PRIOR MODULE FABRICATION. FINAL INSTALLATION OF EXTERIOR ASSEMBLIES IS INCLUDED IN THE ON SITE SCOPE.

REV.	DESCRIPTION	DATE	BY
1	REVISED FOR NEW ENGINE/GENERATOR SELECTION	6/6/22	BCG

ALASKA ENERGY AUTHORITY

PROJECT: NAPASKIAK POWER SYSTEM UPGRADE

TITLE: LOADING DOCK FABRICATION DETAILS

DRAWN BY: JTD	SCALE: AS NOTED
DESIGNED BY: DGT/BCG	DATE: 4/18/22
FILE NAME: NAPS PP S1-5	SHEET: S5.3
PROJECT NUMBER:	

P.O. 111405, Anchorage, AK 99511 (907)349-0100

REV#1 ISSUED  
JUNE 2022



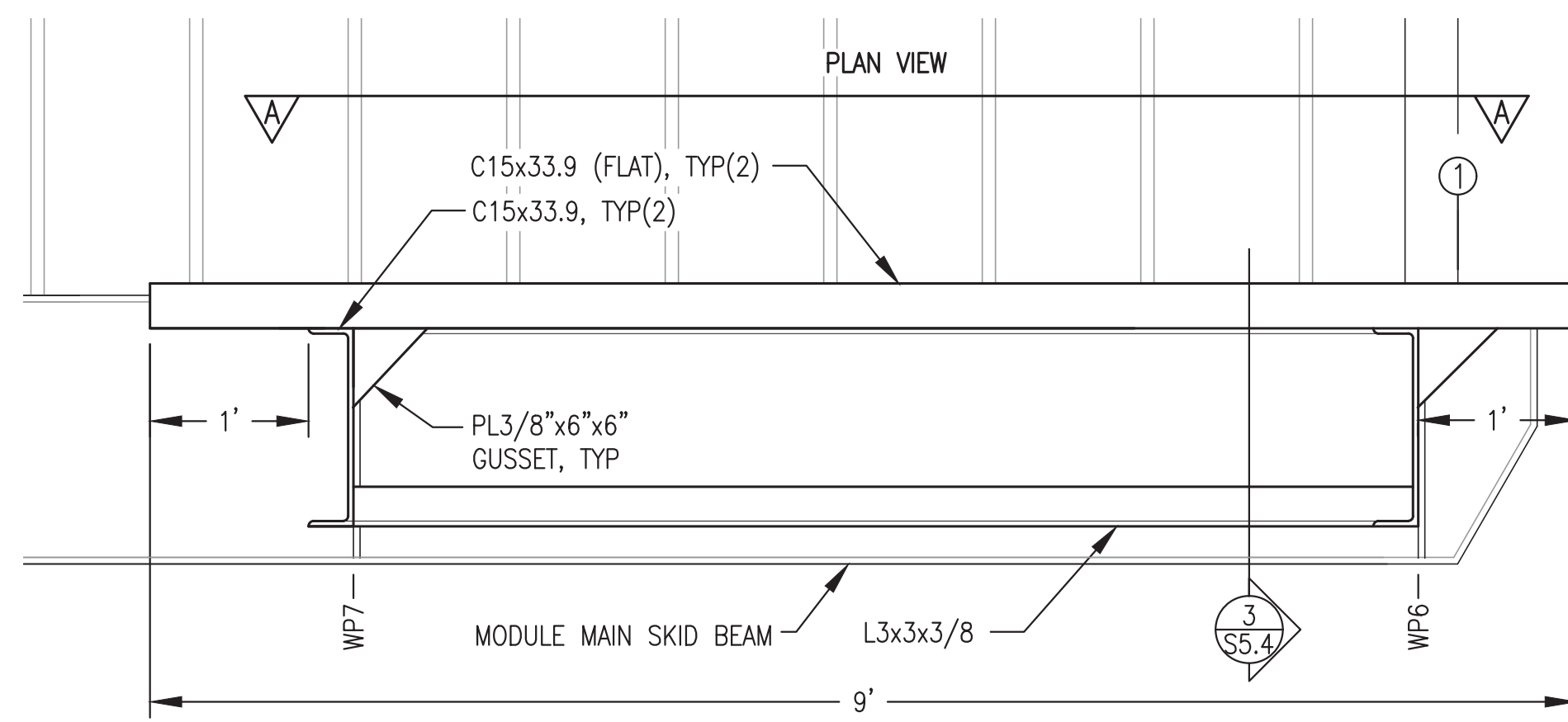

ELEVATION

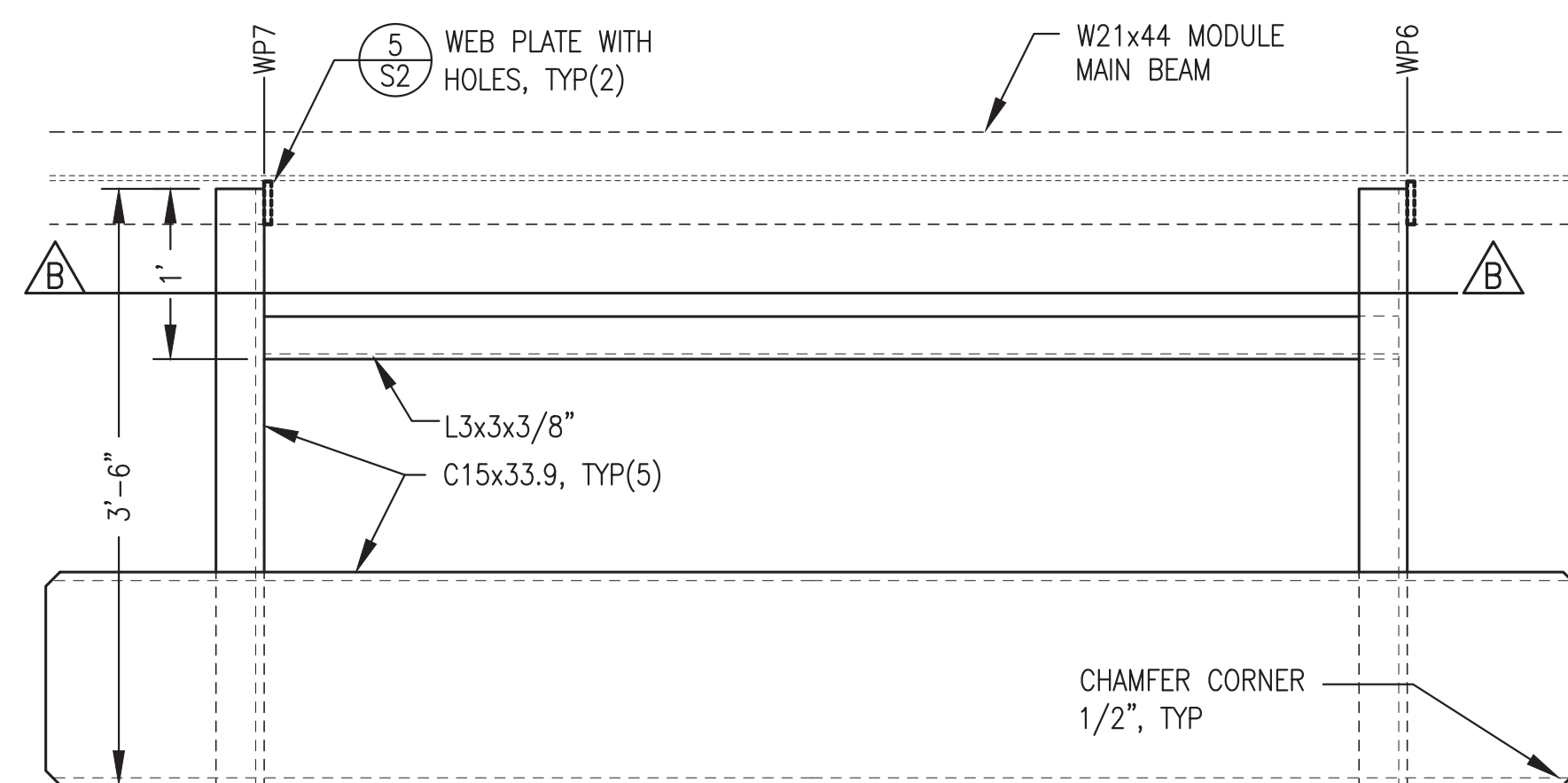

PLAN VIEW A-A

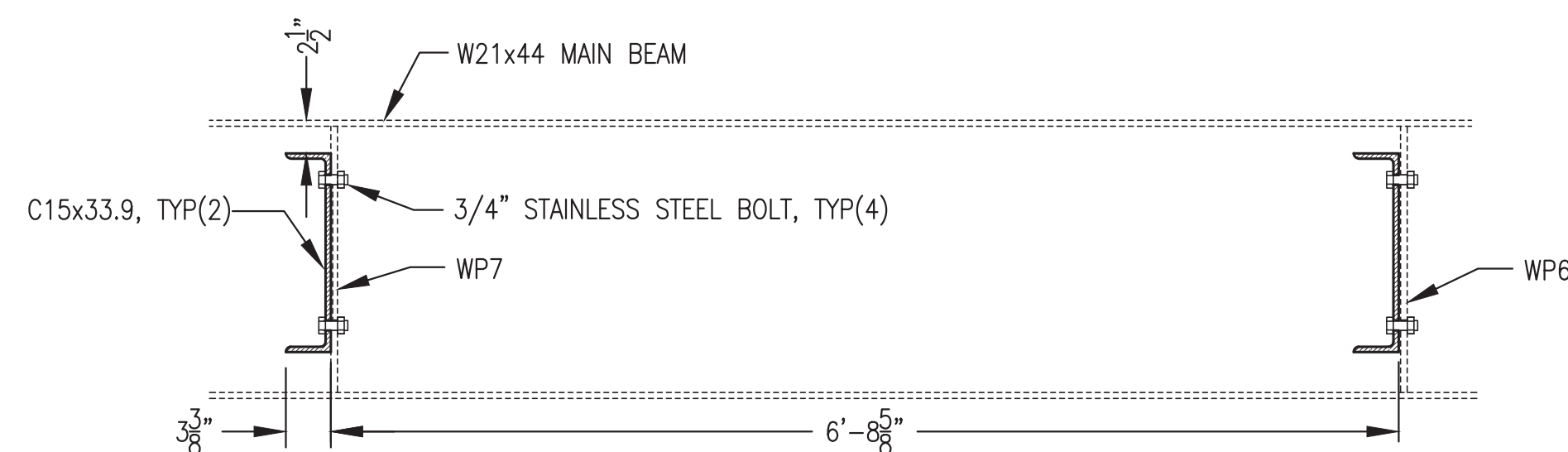

SECTION B-B

1 RADIATOR SUPPORT ELEVATION  
S5.4 1'-1'-0"

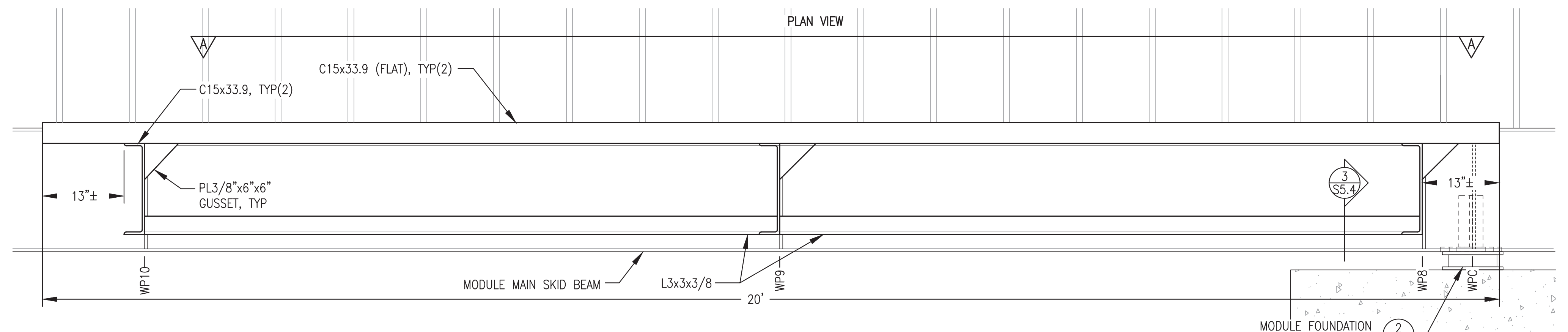

ELEVATION

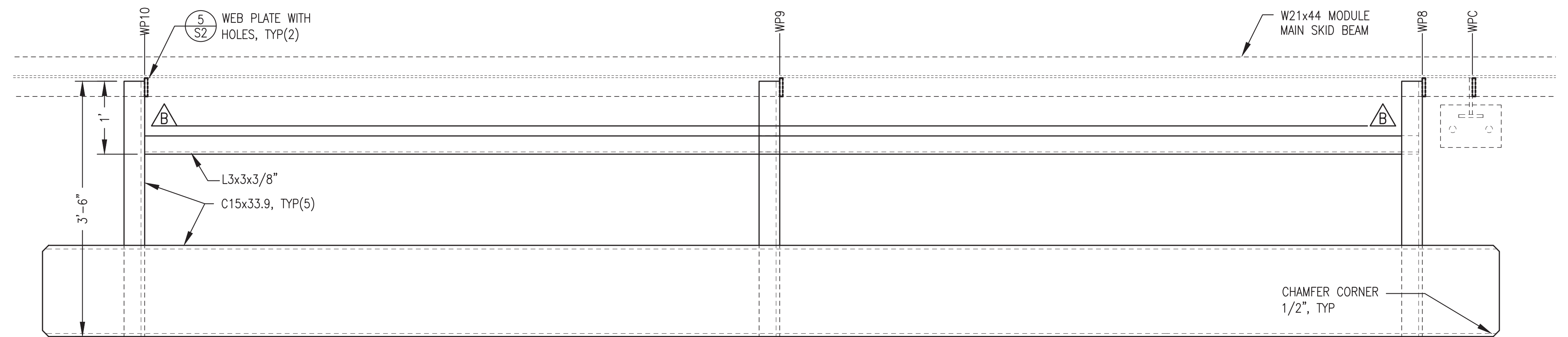

PLAN VIEW A-A

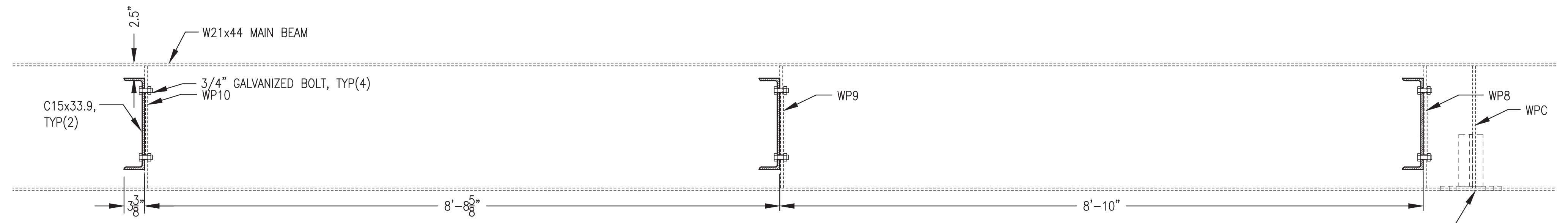

SECTION B-B

2 CHARGE AIR COOLER SUPPORT ELEVATION  
S5.4 1'-1'-0"

ALL EXTERIOR ASSEMBLIES THIS SHEET WERE FABRICATED AS PART OF THE PRIOR MODULE FABRICATION. FINAL INSTALLATION OF EXTERIOR ASSEMBLIES IS INCLUDED IN THE ON SITE SCOPE.

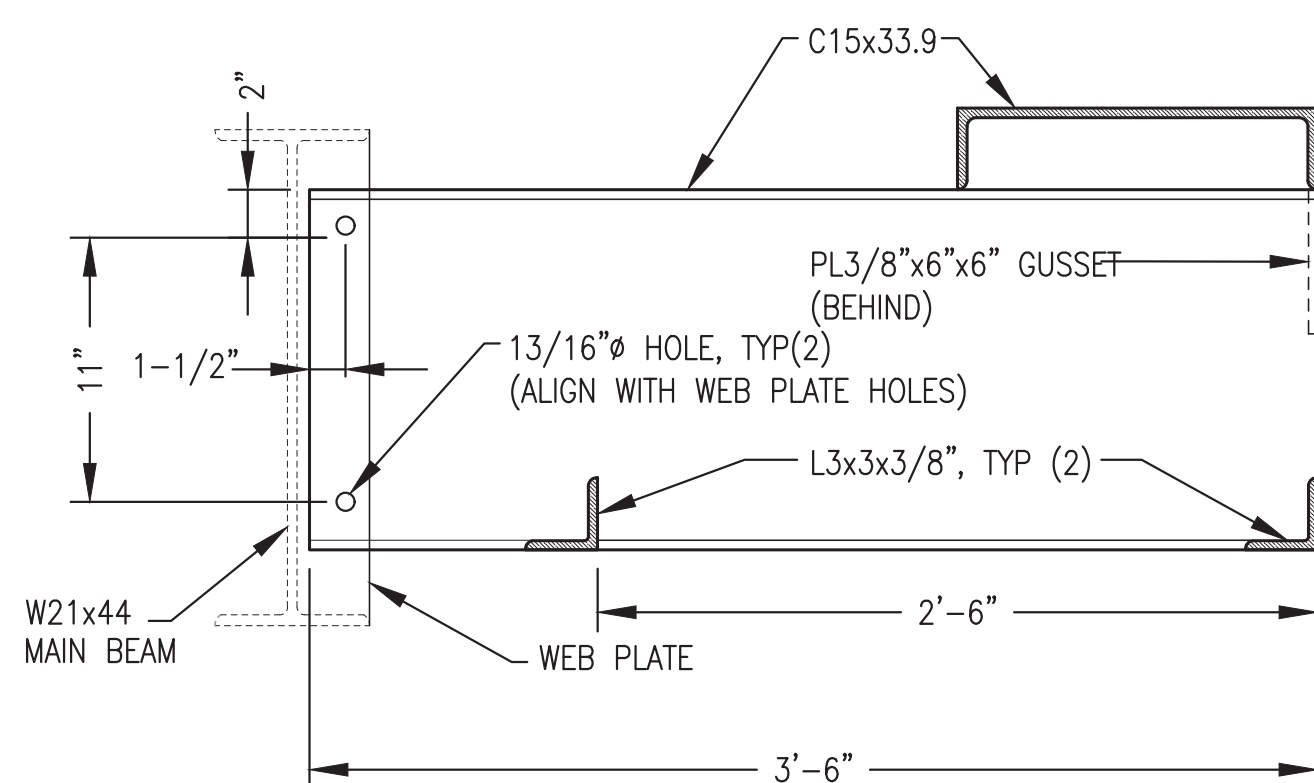

3 TYPICAL SUPPORT SECTION  
S5.4 1'-1/2'-1'-0"

REV#1 ISSUED  
JUNE 2022

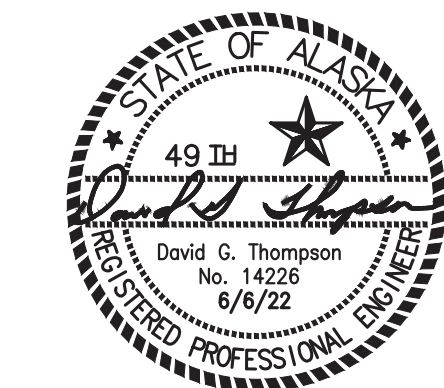

1	REVISED FOR NEW ENGINE/GENERATOR SELECTION	6/6/22	BCG
REV.	DESCRIPTION	DATE	BY
 ALASKA ENERGY AUTHORITY			
PROJECT: NAPASKIAK POWER SYSTEM UPGRADE			
TITLE: RADIATOR & CHARGE AIR COOLER SUPPORT FABRICATION DETAILS			
DRAWN BY: JTD		SCALE: AS NOTED	
DESIGNED BY: DGT/BCG		DATE: 4/18/22	
FILE NAME: NAPS PP S1-5		SHEET:	
PROJECT NUMBER:		<b>S5.4</b>	
P.O. 111405, Anchorage, AK 99511 (907)349-0100			

**PIPING LEGEND**

	BUTTERFLY VALVE
	BALL VALVE
	CHECK VALVE
	HOSE END DRAIN VALVE
	GAUGE COCK
	Y-STRAINER
	AUTOMATIC AIR VENT
	FLEXIBLE CONNECTOR
	FLANGED JOINT
	UNION
	ELBOW TURNED UP
	ELBOW TURNED DOWN
	PIPING CONNECTION (TEE)
	PIPING REDUCER
	DIRECTION OF FLOW

**INSTRUMENT/CONTROL LEGEND**

	PRESSURE GAUGE
	ANALOG THERMOMETER
	DIGITAL THERMOMETER
	TEMPERATURE TRANSMITTER
	TEMPERATURE SENSOR
	PRESSURE TRANSMITTER
	DIFFERENTIAL PRES GAUGE
	FLOW METER
	FLOAT SWITCH
	LOW COOLANT SWITCH
	TANK LEVEL MONITOR
	LEVEL SENSOR PROBE
	GLYCOL LEVEL SENSOR

NOTE: SEE ELECTRICAL FOR ADDITIONAL DETAIL ON CONTROL & INSTRUMENTATION DEVICES

**ABBREVIATIONS**

Ø	DIAMETER (PHASE)
A	AMPS
AFF	ABOVE FINISHED FLOOR
BTU	BRITISH THERMAL UNIT
DFR	DIESEL FUEL RETURN
DFS	DIESEL FUEL SUPPLY
ECR	ENGINE COOLANT RETURN
ECS	ENGINE COOLANT SUPPLY
EWT	ENTERING WATER TEMPERATURE
EXIST	EXISTING
FPT	FEMALE PIPE THREAD
GA	GAUGE
GALV	GALVANIZED
GPM	GALLONS PER MINUTE
GRC	GALVANIZED RIGID CONDUIT
HP	HORSEPOWER
HYR	HYDRONIC RETURN
HYS	HYDRONIC SUPPLY
ID	INSIDE DIAMETER
KW	KILOWATT
LT	LIQUID TIGHT
LWT	LEAVING WATER TEMPERATURE
MAX	MAXIMUM
MBH	THOUSAND BTU PER HOUR
MIN	MINIMUM
MPT	MALE PIPE THREAD
NC	NORMALLY CLOSED
NO	NORMALLY OPEN
OC	ON CENTER
OD	OUTSIDE DIAMETER
PRV	PRESSURE RELIEF VALVE
PSI	POUNDS/PER SQUARE INCH
PSID	PSI DIFFERENTIAL
PSIG	PSI GAUGE
SCH	SCHEDULE
TDH	TOTAL DEVELOPED HEAD
TYP	TYPICAL
UOR	USED OIL RETURN
V	VOLTS
W	WATTS
WG	WATER GAUGE

**ENGINE COOLING SYSTEM EQUIPMENT SCHEDULE**

SYMBOL	SERVICE/FUNCTION	DESCRIPTION	MANUFACTURER/MODEL
R-1 R-2	GLYCOL RADIATOR	SINGLE PASS, 5 ROW, VERTICAL CORE, 3" FLANGED CONNECTIONS, GALVANIZED OR EPOXY COATING, EXPANDED METAL GUARD. 15,000 BTU/MIN AT 80°F AMBIENT, 70 GPM 50% ETHYLENE GLYCOL AT 200F IN, 0.5 PSI MAX GLYCOL PRESSURE DROP. 5 HP, 460 V, 3 PH MOTOR SUITABLE FOR VFD OPERATION AT 10:1 TURNDOWN RATIO.	DIESEL RADIATOR PART NO. DR3734
CAC1 CAC-2 CAC-3	GEN#3 CHARGE AIR COOLER	SINGLE PASS, VERTICAL ALUMINUM CORE, 4" FLANGED TOP CONNECTIONS, EPOXY COATING, EXPANDED METAL GUARD. 1340 SCFM CHARGE AIR AT 395F IN AND 110F OUT AT 75F AMBIENT, 34" H2O MAX CHARGE AIR PRESSURE DROP. 5 HP, 460 V, 3 PH, MOTOR SUITABLE FOR VFD OPERATION AT 10:1 TURNDOWN RATIO.	DIESEL RADIATOR PART NO. DR3376A
TV-1	COOLANT THERMOSTATIC VALVE	4" ANSI 125# FLAT FACED FLANGES, CAST IRON BODY, FACTORY SET NON-ADJUSTABLE FIELD REPLACEABLE THERMOSTATIC ELEMENTS, 175F NOMINAL TEMPERATURE	FPE PART NO. A4010-175
TV-2	HEAT RECOV. THERMOSTATIC VALVE	2-1/2" ANSI 125# FLAT FACED FLANGES, CAST IRON BODY, FACTORY SET NON-ADJUSTABLE FIELD REPLACEABLE THERMOSTATIC ELEMENTS, 185F NOMINAL TEMPERATURE,	FPE PART NO. A2510-185
ET-1	GEN COOLANT EXPANSION TANK	30 GALLON CAPACITY TANK, 12.75" O.D x 60" LONG FABRICATED STEEL TANK, SEE FABRICATION DETAIL	CUSTOM FABRICATION
HP-EC	ENGINE COOLANT FILL HAND PUMP	DOUBLE ACTION PISTON HAND PUMP, ALUM HOUSING, SS PISTON SHAFT & LINER, BUNA-N SEALS, ANTI-SIPHONING VALVE.	GPI MODEL HP-100
G-EC	ENGINE COOLANT GLYCOL TANK LEVEL GAUGE	MAGNETIC OPERATED SPIRAL GAUGE FOR #1 DIESEL, 25 PSIG MAX OPERATING PRESSURE, 35" LIQUID COLUMN PLUS 4" RISER.	ROCHESTER MODEL 8660
GT-1	ENGINE COOLANT GLYCOL STORAGE TANK	60 GALLON CAPACITY, 36"x10"x44" HIGH FABRICATED RECTANGULAR STEEL TANK, SEE FABRICATION DETAIL	CUSTOM FABRICATION

**MODULE HEAT RECOVERY SYSTEM & PLANT HEATING EQUIPMENT SCHEDULE:**

SYMBOL	SERVICE/FUNCTION	DESCRIPTION	MANUFACTURER/MODEL
HX-1	POWER PLANT HEAT EXCHANGER	316 SS PLATES, BRAZED CONST., 2-1/2" SOLDER CUP PORTS, 500 MBH MIN CAPACITY. PRIMARY: 60 GPM 195F EWT (50% ETHYLENE) 3.0 PSI MAX WPD, SECONDARY: 60 GPM 185F LWT (50% PROPYLENE) 3.0 PSI MAX WPD	SWEP INTERNATIONAL AB B120THx90/1P-SC-4x66.85
P-CUH1	CONTROL ROOM HEAT	1 GPM AT 18' TDH, 1/25HP, 115V, 1Ø. PROVIDE WITH 3/4" SOLDER COMPANION SHUT OFF FLANGES, GASKETS, & BOLTS.	GRUNDFOS UPS 15-58FC SPEED 3
P-HR1A	HEAT RECOV. PRIMARY	55 GPM AT 9' TDH (SET TO CONSTANT PRESSURE MODE CP1), 1/3 HP, 115V, 1Ø, WITH 2" NPT FLANGES	GRUNDFOS MAGNA1 50-80F CP1
P-HR1B	HEAT RECOV. SECONDARY	30 GPM AT 38' TDH (SET TO CONSTANT PRESSURE MODE CP3), 1-1/2 HP, 208-230V, 1Ø, WITH 2-1/2" NPT FLANGES	GRUNDFOS MAGNA1 65-150F CP3
CUH-1	CONTROL ROOM HEAT	WALL MOUNTED HOT WATER CABINET UNIT HEATER, 17 MBH AT 1 GPM 180F EWT & 60F EAT.	TOYOTOMI HC-190 WITH WALL MOUNT BRACKET
ET-2	HEAT RECOV. EXP. TANK	BLADDER TYPE EXPANSION TANK, 159 GALLON TANK, 56 GALLON ACCEPTANCE VOL, 125 PSIG WORKING PRESSURE, 12 PSIG PRE-CHARGE.	AMTROL AX-260

**PIPE/TUBING STRUT CLAMP SCHEDULE**

PIPE/TUBE	CLAMP #	PIPE/TUBE	CLAMP #	NOTES:
1/2" COPPER	BVT062	1/2" STEEL	B2008	1) ALL CLAMP NUMBERS ARE B-LINE. EQUIVALENT EQUALS ACCEPTABLE. 2) ALL COPPER TUBE CLAMPS TO BE CUSHIONED, VIBRA-CLAMP. 3) ALL STEEL PIPE CLAMPS NOT CUSHIONED. USE FOR ALL STEEL PIPE AND RIGID CONDUIT. 4) SEE PLANS, ELEVATIONS, ISOMETRICS, AND DETAILS FOR ACTUAL PIPE SIZES.
3/4" COPPER	BVT087	3/4" STEEL	B2009	
1" COPPER	BVT112	1" STEEL	B2010	
1-1/4" COPPER	BVT125	1-1/4" STEEL	B2011	
1-1/2" COPPER	BVT162	1-1/2" STEEL	B2012	
2" COPPER	BVT212	2" STEEL	B2013	
2-1/2" COPPER	BVT262	2-1/2" STEEL	B2014	
3" COPPER	BVT312	3" STEEL	B2015	

**VENTILATION EQUIPMENT SCHEDULE:**

SYMBOL	SERVICE/FUNCTION	DESCRIPTION	MANUFACTURER/MODEL
EF-1 EF-2 EF-3	GENERATION ROOM EXHAUST FANS	DIRECT DRIVE 14"Ø PROPELLER SIDEWALL EXHAUST FAN, 2,100 CFM AT 0.375" SP, 1,750 RPM. FURNISH WITH SPECIAL 1/2 HP, 115 V, 1 PH VARIGREEN MOTOR WITH OPTIONAL 0-10V LEADS AND OPTIONAL TRANSFORMER	GREENHECK SE1-14-436-VG (1/2 HP)
EF-1 EF-2 EF-3 COMB AIR	FAN & INTAKE DAMPERS	OPPOSED BLADE LOW-LEAKAGE CONTROL DAMPER, AIRFOIL BLADES, GALVANIZED STEEL CONSTRUCTION, ACETAL BEARINGS, STAINLESS STEEL JAMB SEALS, TPE BLADE SEALS.	GREENHECK VCD-33
MD	MOTORIZED DAMPER ACTUATOR	MULTI-VOLTAGE SPRING RETURN ACTUATOR	BELIMO AF-BUP

**FUEL SYSTEM EQUIPMENT SCHEDULE**

SYMBOL	SERVICE/FUNCTION	DESCRIPTION	MANUFACTURER/MODEL
P-DF1	DAY TANK FILL PUMP	ROTARY GEAR PUMP, 5 GPM @ 25 PSID, C-FRAME MOUNT, 1" FPT INLET AND OUTLET, IRON CONSTRUCTION, STEEL SHAFT, CARBON GRAPHITE BUSHINGS, BUNA-N LIP SEAL, WITH 75 PSID INTERNAL PRV. DIRECT MOUNT TO FOOT MOUNT 56C FRAME MOTOR, 1,200 RPM, 1/2 HP, 115VAC.	GORMAN RUPP GMC1DC3-B-40C PUMP AND CENTURY #C827 MOTOR FOR FIELD ASSEMBLY
P-DF2	DIESEL CIRC. PUMP	ROTARY GEAR PUMP GEAR PUMP - 1.2 GPH @ 15 PSID, 1/8" FPT INLET AND OUTLET, PEEK GEARS, PTFE SEALS, MAGNETICALLY COUPLED TO FOOT MOUNT 56C FRAME MOTOR, 1,725 RPM, 1/2 HP, 115VAC.	MICROPUMP GA-V21J8FS.A PUMP WITH #81518 ADAPTER & CENTURY #C826V1 MOTOR
P-UO1	USED OIL DRAIN PUMP	ROTARY GEAR PUMP GEAR PUMP - 1.2 GPH @ 15 PSID, 1/8" FPT INLET AND OUTLET, PEEK GEARS, PTFE SEALS, MAGNETICALLY COUPLED TO FOOT MOUNT 56C FRAME MOTOR, 1,725 RPM, 1/2 HP, 115VAC.	MICROPUMP GA-V21J8FS.A PUMP WITH #81518 ADAPTER & CENTURY #C826V1 MOTOR
P-UO2	USED OIL INJECTION PUMP	ROTARY GEAR PUMP GEAR PUMP - 1.2 GPH @ 15 PSID, 1/8" FPT INLET AND OUTLET, PEEK GEARS, PTFE SEALS, MAGNETICALLY COUPLED TO FOOT MOUNT 56C FRAME MOTOR, 1,725 RPM, 1/2 HP, 115VAC.	MICROPUMP GA-V21J8FS.A PUMP WITH #81518 ADAPTER & CENTURY #C826V1 MOTOR
HP-DT	DAY TANK FILL HAND PUMP	DOUBLE ACTION PISTON HAND PUMP, ALUM HOUSING, SS PISTON SHAFT & LINER, BUNA-N SEALS, ANTI-SIPHONING VALVE.	GPI MODEL HP-100
G-DI	DAY TANK LEVEL GAUGE	MAGNETIC OPERATED SPIRAL GAUGE FOR #1 DIESEL, 25 PSIG MAX OPERATING PRESSURE, 35" LIQUID COLUMN PLUS 4" RISER.	ROCHESTER MODEL 8660
M-DI	DAY TANK METER	STEEL BODY, 1" ANSI 150# FLANGED ENDS, 20-800 GPH FLOW RANGE. 0-RINGS AND SEALS COMPATIBLE WITH #1 DIESEL, DIRECT READ 6-DIGIT REGISTER TO 0.1 GAL, DRY CONTACT PULSER.	ISTEC CONTOIL 9226-F
F-DI	DAY TANK FILTER	THREE FILTER BANK WITH INDIVIDUAL FILTER ISOLATION VALVES, IMPACT RESISTANT "SEE-THRU" BOWLS, 15 PSIG WORKING PRESSURE. WITH 1/2" WATER PROBE PORT & 3 EACH WATER-IN-FUEL DETECTION KITS. INSTALL 3 EACH 10 MICRON AQUABLOC FILTER ELEMENTS & FURNISH 3 SPARES.	RACOR TURBINE 791000FV10-P WATER-IN-FUEL RR30880E ELEMENTS 2020V10
F-UOB	USED OIL BLENDER FILTER	CUSTOM FABRICATED FILTER BANK. FURNISH WITH TWO STAGE ELEMENTS: 10 MICRON HYDROSORB II FILTER 2 MICRON PARTICULATE FILTER PROVIDE 3 OF EACH ELEMENT TYPE	CIM-TEK #30034 (HYDROSORB) CIM-TEK #30066 (2 MICRON)
FOG-1	FUEL OIL COOLER	HORIZONTAL CORE, 1-1/2" FLANGED CONNECTIONS, ENAMEL COATING, EXPANDED METAL DISCHARGE GUARD. 10 GPM NO.1 DIESEL FUEL, 450BTU/MIN WITH 120F MAX OIL OUTLET TEMPERATURE AT 80F AMBIENT, 1 PSI MAX OIL PRESSURE DROP. 1-1/2 HP, 208V, 3PH MOTOR SUITABLE FOR VFD OPERATION AT 10:1.	DIESEL RADIATOR PART NO. DR4147-00
ABV-1	ACTUATED BALL VALVE	ACTUATED BALL VALVE ASSEMBLY RATED TO -50F. TYPE 304 STAINLESS STEEL FABRICATED COUPLING BRACKET, SHAFT, AND FASTENERS CONFIGURED TO ALLOW WRENCH ACCESS FOR MANUAL OPERATION OF VALVE WITHOUT REMOVING ACTUATOR. LOW TEMP BALL VALVE, 150# RF FLANGED ENDS. ELECTRIC ACTUATOR WITH OPERATING VOLTAGE, NEMA RATING, AND TORQUE AS INDICATED. CONFIGURE WITHOUT MANUAL OVERRIDE SHAFT EXTENSION. FURNISH WITH PTC SELF REGULATING HEATER, AUXILIARY SWITCH SET (AUXILIARY SWITCHES 3 & 4), AND EXXON BEACON 325 SEVERE COLD LUBRICANT.	VALVE ASSEMBLY: DG VALVE (780) 413-1760  1" BALL VALVE - 151 IN-LB OPERATING TORQUE @ -50F NUTRON MODEL T3-R10R01LZ OR KECKLEY PART # BVF1RF2RSSRGL-100  NEMA 7 ACTUATOR - 600 IN-LBS TORQUE, 10 SECOND STROKE TIME, 0.50 LOCKED ROTOR AMPS. RCS MODEL SXR-1023
PF	PIPELINE FILTER	SINGLE ELEMENT FILTER, DIE-CAST ALUMINUM HEAD, EPOXY COATED CARBON STEEL FILTER HOUSING COMPLETE WITH 1/8" VENT AND DRAIN VALVES AND BUNA-N O-RING, 1-1/2" FPT INLET/OUTLET, 150 PSIG MAXIMUM OPERATING PRESSURE, 50 GPM @ 3 PSI TDH. PROVIDE THREE SPARE 25 MICRON AQUACON DIESEL FUEL FILTER CARTRIDGES AND THREE SPARE BUNA-N HOUSING O-RINGS.	VELCON FILTER HOUSING: #VF-61E FILTER CARTRIDGES: #AD-51225 HOUSING O-RING: #G-0986

**INSTRUMENTATION SCHEDULE**

SYMBOL	SERVICE/FUNCTION	DESCRIPTION	MANUFACTURER/MODEL
TT	TEMPERATURE TRANSMITTER	RTD, 20-240°F RANGE, 4-20mA OUTPUT, 1/2" NPT PIPING CONNECTION, 6mm DIAMETER BY 2.5" LONG STEM, HIRSCHMANN ELECTRICAL CONNECTION	NOSHOK 800-20/240-1-1-8-8-025-6
PT	PRESSURE TRANSMITTER	0-60 PSIG RANGE, 4-20mA OUTPUT, 1/4" NPT PIPING CONNECTION, HIRSCHMANN ELECTRICAL CONNECTION	NOSHOK 100-60-1-1-2-7
FM	HEAT RECOVERY FLOW METER	150# ANSI FLANGED CONNECTION, SIZE AS INDICATED, PTFE LINER, HASTELLOY C ELECTRODES, RATED FOR 210F OPERATION. FURNISH WITH TRANSMITTER FOR DIRECT AND REMOTE MOUNTING, 115/230 VAC, 50/60 HZ, AND NEMA 4X BODY.	SIEMENS SITRANS METER: FM MAGFLO MAG 3100 TRANSMITTER: F M MAGFLO MAG 5000, CODE NO. FDK: 7ME6910, OPTION 1AA10-1AA0
LCA	GLYCOL TANK LOW COOLANT ALARM	LOW COOLANT LEVEL ALARM FLOAT SWITCH, SEE MECHANICAL FOR INSTALLATION DETAILS	MURPHY EL-150-K1
GLS	GLYCOL TANK LEVEL SENSOR PROBE	12" PROBE, 2" NPT TANK CONNECTION, SS FLOAT, 1/4" RESOLUTION, NEMA 4 ENCLOSURE WITH SIGNAL CONDITIONER AND 1/2" NPT CONDUIT CONNECTION	INNOVATIVE COMPONENTS CLM-2012-SS
FS	DAY TANK/HOPPER FLOAT SWITCH	VERTICAL ACTION FLOAT SWITCH, REVERSIBLE 70VASPST NC/NO SWITCH, 1/8" NPT, 1" MAX Ø BUNA-N FLOAT FOR S.G.=.47, MINIMUM 60" LONG PVC COATED #20 AWG LEAD WIRES	INNOVATIVE COMPONENTS LS-12-111/2
TLM	TANK LEVEL MONITOR PANEL	TANK LEVEL MONITOR CONSOLE FOR UP TO SIX TANKS, COLOR LCD SCREEN, ETHERNET CONNECTION WITH WEB INTERFACE, PROGRAMMABLE VOLUME CALCULATIONS WITH TEMPERATURE COMPENSATION	FRANKLIN/INCON EVO 200
LSP	DAY TANK/HOPPER TANK LEVEL SENSOR PROBE	TOP-MOUNT TANK PROBE WITH INSTALLATION KIT FOR 2" NPT RISER, WATER TIGHT COMPRESSION GLAND FITTING FOR CABLE ENTRANCE. FRANKLIN FUEL SYSTEMS, NO SUBSTITUTES. PROBE AND RISER LENGTH AS INDICATED ON INSTALLATION DETAILS.	4' TANK PROBE: FMP-LL3-53-I 2' TANK PROBE: FMP-LL3-29-I FLOAT: TSP-IDF2 2" FOR DIESEL INSTALLATION KIT: TSP-C2A
TS	FUEL OIL RETURN TEMP SENSOR	PTC PROBE, 2" LONG, WITH 2m LONG JACKET CABLE (FURNISHED WITH TEMPERATURE CONTROLLER ELECTRICAL TEM 24)	PENN A99BB-200C

EQUIPMENT REQUIREMENTS FOR APPROVED EQUALS (APPLIES TO ALL SCHEDULES): SPECIFIC PARTS MANUFACTURER AND MODEL SELECTED NOT ONLY TO MEET PERFORMANCE FUNCTION BUT ALSO TO COORDINATE AND INTERFACE WITH OTHER DEVICES AND SYSTEMS. APPROVED EQUAL SUBSTITUTIONS WILL BE ALLOWED ONLY BY ENGINEER'S APPROVAL. TO OBTAIN APPROVAL, SUBMITTALS MUST CLEARLY DEMONSTRATE HOW SUBSTITUTE ITEM MEETS OR EXCEEDS SPECIFIED ITEM QUALITY AND PERFORMANCE CHARACTERISTICS AND ALSO COMPLIES WITH MECHANICAL AND/OR ELECTRICAL CONNECTIONS AND PHYSICAL LAYOUT REQUIREMENTS.

ALL MATERIALS AND EQUIPMENT ON SCHEDULES THIS SHEET WERE FURNISHED AS PART OF THE PRIOR MODULE ASSEMBLY PROJECT EXCEPT FOR THOSE ITEMS SPECIFICALLY INDICATED IN RED CLOUDS WHICH ARE TO BE FURNISHED AND INSTALLED AS PART OF THE ON SITE SCOPE.

REV #1 ISSUED FOR ON SITE CONSTRUCTION DECEMBER 2022

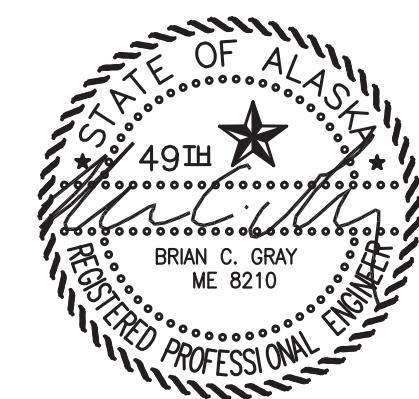

1	REVISED TO COORDINATE WITH FINAL ON-SITE DESIGN	12/15/22	BCG
REV.	DESCRIPTION	DATE	BY
<p>ALASKA ENERGY AUTHORITY</p>			
PROJECT: NAPASKIAK POWER SYSTEM UPGRADE			
TITLE: MECHANICAL LEGENDS & SCHEDULES			
DRAWN BY: JTD		SCALE: AS NOTED	
DESIGNED BY: BCG		DATE: 7/29/22	
FILE NAME: NAPS PP M1		SHEET: M1.1	
PROJECT NUMBER: P.O. 111405, Anchorage, AK 99511 (907)349-0100			

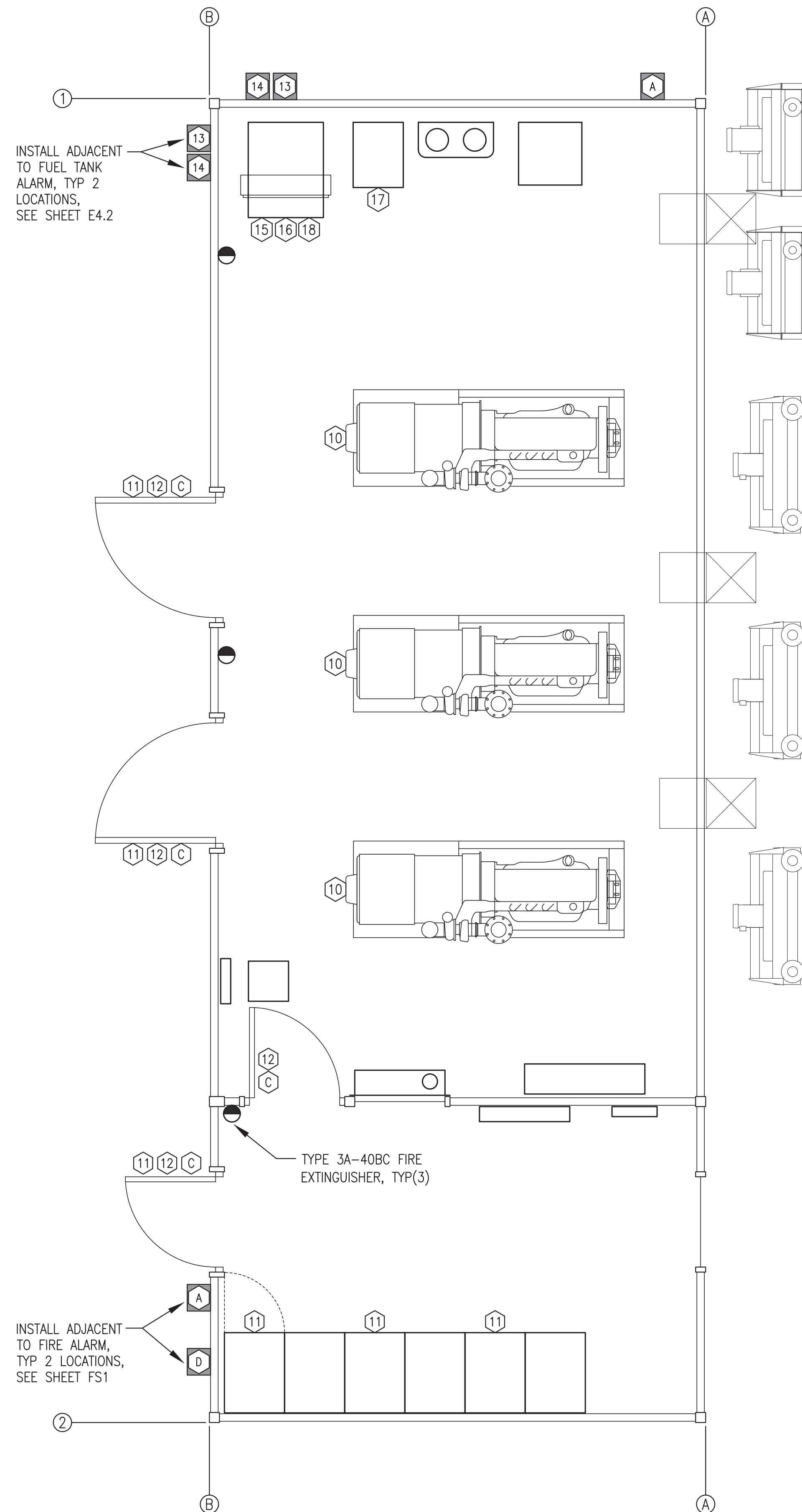

**VALVE TAG SCHEDULE:**

GREEN (DIESEL FUEL)

- (21) "NORMALLY OPEN, CLOSE ONLY FOR EMERGENCIES & TEMPORARY MAINTENANCE OF DAY TANK & DEVICES"
- (22) "NORMALLY CLOSED, OPEN ONLY FOR HAND PRIMING DAY TANK"
- (23) "NORMALLY OPEN, CLOSE ONLY FOR TEMPORARY MAINTENANCE OF BLENDER"
- (24) "NORMALLY OPEN, CLOSE ONLY FOR TEMPORARY MAINTENANCE OF ENGINE"
- (25) "NORMALLY CLOSED, OPEN ONLY FOR TEMPORARY MAINTENANCE OF COOLER"
- (26) "NORMALLY OPEN, CLOSE ONLY FOR TEMPORARY MAINTENANCE OF FILTER"

BROWN (USED OIL)

- (41) "NORMALLY CLOSED, OPEN ONLY FOR ENGINE OIL CHANGE"
- (42) "BLENDER FILTER #1, 10 MICRON HYDROSORB" (DECAL)
- (43) "BLENDER FILTER #2, 2 MICRON PARTICULATE" (DECAL)

PINK (COOLING/ETHYLENE GLYCOL)

- (51) "NORMALLY CLOSED, OPEN ONLY FOR ADDING COOLANT - ETHYLENE GLYCOL ONLY"
- (52) "NORMALLY CLOSED, OPEN ONLY ON HIGH COOLANT TEMPERATURE ALARM"
- (53) "NORMALLY OPEN, CLOSE ONLY ON HIGH COOLANT TEMPERATURE ALARM"
- (54) "NORMALLY OPEN, HEAT RECOVERY SUPPLY"
- (55) "NORMALLY OPEN, HEAT RECOVERY RETURN"

YELLOW (HEAT RECOVERY/PROPYLENE GLYCOL)

- (61) "NORMALLY CLOSED, OPEN ONLY FOR ADDING FLUID - PROPYLENE GLYCOL ONLY"
- (62) "NORMALLY OPEN, HEAT RECOVERY SUPPLY"
- (63) "NORMALLY OPEN, HEAT RECOVERY RETURN"
- (64) "NORMALLY CLOSED, OPEN ONLY FOR AIR BLEED & PURGE"
- (65) "NORMALLY OPEN, CLOSE ONLY TO CLEAN STRAINER"
- (66) "NORMALLY OPEN, CLOSE ONLY FOR TEMPORARY MAINTENANCE"

**SPECIFICATIONS:**

VALVE TAGS - 3"x5"x.08" ALUMINUM, 3/16" HOLES IN ALL FOUR CORNERS, BLACK GERBER THERMAL TRANSFER FILM PRINTED LETTERS ON GERBER 220 HIGH PERFORMANCE VINYL BACKGROUND, COLOR AS INDICATED, ONE SIDE ONLY. WARNING LITES OR APPROVED EQUAL.

DECALS - WHERE NOTED AS DECALS PROVIDE WITHOUT ALUMINUM BACKING PLATE.

**INSTALLATION NOTES:**

- 1) SEE DRAWINGS THAT FOLLOW FOR LOCATIONS OF ALL SPECIFIC FUNCTION TAGS.
- 2) SECURE EACH METAL TAG TIGHT TO VALVE, PIPE, OR DEVICE WITH STAINLESS STEEL SAFETY WIRE THROUGH ALL FOUR CORNERS OR FASTEN TO ADJACENT WALL OR SECTION OF STRUT WITH SCREWS.
- 3) APPLY DECALS TO CLEAN SMOOTH SURFACES OF EQUIPMENT OR ON ADJACENT WALL.
- 4) FOR ALL VALVES NOT INDICATED WITH A SPECIFIC FUNCTION TAG PROVIDE 1-1/2" ROUND BRASS TAG LABELED "N.O." FOR NORMALLY OPEN VALVES AND 1-1/2" SQUARE BRASS TAG LABELED "N.C." FOR NORMALLY CLOSED VALVES. SECURE TAGS TO VALVE OR ADJACENT PIPE WITH BEADED BRASS CHAIN.

**WARNING SIGN & INFORMATIONAL PLACARD SCHEDULE:**

PROVIDE DECALS AND SIGN BOARDS AS SPECIFIED BELOW IN ACCORDANCE WITH THE SCHEDULE. INSTALL WHERE SHOWN ON THE WARNING SIGN/PLACARD PLAN THIS SHEET AND OTHER REFERENCED SHEETS.

**DECALS**  
DECALS TO BE WHITE NON-REFLECTIVE VINYL BACKGROUND, 3M 3650-10, WITH 3M SERIES 225 HIGH PERFORMANCE VINYL LETTERS, ONE SIDE ONLY, SELF ADHESIVE BACK. NOMINAL 10"x14" SIZE UNLESS INDICATED OTHERWISE OR REQUIRED TO BE LARGER FOR SPECIFIED LETTER SIZE. WARNING LITES OR EQUAL. INSTALL ON FACE OF DOORS OR ELECTRICAL ENCLOSURES WHERE INDICATED. CLEAN SURFACES AND APPLY IN ACCORDANCE WITH MANUFACTURER'S INSTRUCTIONS.

**BOARDS**  
SIGN BOARDS TO BE EQUAL TO DECALS EXCEPT MOUNTED ON 0.08" ALUMINUM PLATE. PROVIDE 3/16" HOLES IN ALL FOUR CORNERS. ATTACH TO CHAIN LINK FENCING WITH HOG RINGS OR STAINLESS STEEL TIES. ATTACH TO WALLS OR STRUCTURES WITH STAINLESS STEEL SCREWS OR BOLTS.

**WARNING SIGNS** - RED LETTERING ON WHITE BACKGROUND.

- (A) "FIRE ALARM"
- (C) "CAUTION, ROOM PROTECTED BY WATER MIST FIRE PROTECTION SYSTEM, IN CASE OF FIRE KEEP DOOR CLOSED AND DO NOT ENTER"
- (D) "FLASHING LIGHT MEANS FIRE SUPPRESSION AGENT HAS DISCHARGED"
- (I) not used
- (10) "CAUTION: THIS UNIT STARTS AUTOMATICALLY, LOCK & TAG OUT PRIOR TO SERVICE"
- (11) "DANGER HIGH VOLTAGE, AUTHORIZED PERSONNEL ONLY"
- (12) "CAUTION HEARING & EYE PROTECTION REQUIRED"
- (13) "FUEL OIL DAY TANK ALARM"
- (14) "IN CASE OF SPILL CALL DEC 1-800-478-9300"

**INFORMATIONAL PLACARDS** - BLACK LETTERING ON WHITE BACKGROUND

- (15) (15) "LEAVE MAIN VALVE OPEN ON ONLY ONE OF UTILITY TANKS U1-U4 AT A TIME FOR AUTOMATIC DAY TANK FILL. CHECK BULK TANK LEVEL DAILY, SWITCH TO A DIFFERENT BULK TANK WHEN LEVEL DROPS BELOW 12"
- (16) "TO MANUALLY FILL DAY TANK IN CASE OF EMERGENCY:  
1) TURN OFF POWER TO THE DAY TANK CONTROL PANEL  
2) MANUALLY OPEN ACTUATOR VALVE AT TANK FARM USING A WRENCH  
3) OPEN NORMALLY CLOSED VALVE BY HAND PUMP  
4) OPERATE HAND PUMP WHILE MONITORING LEVEL GAUGE"
- (17) "TO CHANGE ENGINE OIL:  
1) VERIFY ENGINE OIL HAS NOT BEEN CONTAMINATED WITH GLYCOL OR OTHER FLUIDS  
2) LOCK & TAG GENERATOR OUT OF SERVICE  
3) OPEN NORMALLY CLOSED DRAIN VALVE AT GEN  
4) TURN ON PUMP TIMER & PUMP OUT ENGINE OIL  
5) CHANGE FILTER & PLACE OLD ONE IN HOPPER  
6) CLOSE DRAIN VALVE & REFILL ENGINE  
7) RUN ENGINE, SHUT OFF, & CHECK DIPSTICK  
8) TOP OFF & PLACE ENGINE BACK IN SERVICE"
- (18) (18) "THE PIPELINE FILTER CONTAINS A WATER BLOCKING ELEMENT. THE ELEMENT SHOULD BE CHANGED AT A MINIMUM EVERY FALL AFTER FREEZE UP AND IF PUMPING RATE SLOWS DOWN. TURN OFF DAY TANK CONTROL PANEL IN POWER PLANT, CLOSE MANUAL BALL VALVE AND CONFIRM THAT ACTUATED BALL VALVE IS FULLY CLOSED PRIOR TO CHANGING FILTER."

ALL DECALS, SIGN BOARDS, FIRE EXTINGUISHERS, AND VALVE TAGS WERE FURNISHED AND INSTALLED AS PART OF THE PRIOR MODULE ASSEMBLY PROJECT EXCEPT FOR THOSE ITEMS SPECIFICALLY INDICATED IN RED CLOUDS WHICH ARE TO BE FURNISHED AND INSTALLED AS PART OF THE ON SITE SCOPE.

ISSUED FOR  
CONSTRUCTION  
JULY 2022

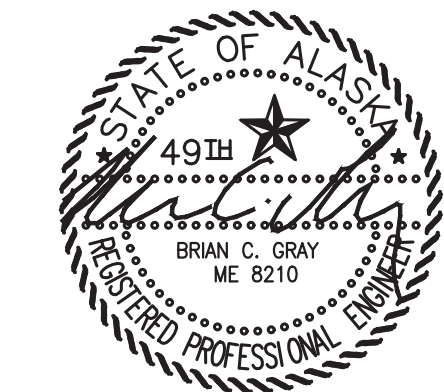

PROJECT: NAPASKIAK POWER SYSTEM UPGRADE		
TITLE: WARNING SIGN & FIRE EXTINGUISHER PLAN, SIGN & VALVE TAG SCHEDULES		
DRAWN BY: JTD	SCALE: AS NOTED	
DESIGNED BY: BCG	DATE: 7/29/22	
FILE NAME: NAPS PP M1	SHEET:	M1.2
P.O. 111405, Anchorage, AK 99511 (907)349-0100	PROJECT NUMBER:	

Final (Permanent) Demand Control Table (PLC)				
Demand Control	Generator(s) On Line	On-line kW (Overload)	Level Increase	Level Decrease
Level 1	One Gen	350	310	---
Level 2	Two Gens	700	620	280
Level 3	All	1050	---	560

Note: All generators are equal capacity. Manually select priority for each.

Temporary Demand Control for Shop Load Test with 300kW Load Bank				
Level	Generator(s)	On-line kW	Level Increase	Level Decrease
Level 1	One Gen	150	135	---
Level 2	Two Gens	300	270	120
Level 3	All	450	---	240

Note: Temporarily set to reduced values in order to test all demand levels.

Engine-Generator Alarm Settings (EZGN Genset Controller)			
Function	Normal Range	Alarm	Shut Down
Overspeed	1795-1805	---	1900 RPM
Oil Pressure	30-50 PSI	14.5 PSI	10 PSI
Air Filter Vacuum	1-10" H2O	15" H2O	20" H2O
Coolant Temp.	180-200°F	210°F	215°F
Exhaust Temp.	500-850°F	900°F	---
Charge Air Temp.	100-120°F	140°F	150°F
Under Frequency	59.5-60.5 Hz	---	58.2 Hz
Over Frequency	59.5-60.5 Hz	---	61.8 Hz
Under Voltage	470-490 V	---	432 V
Over Voltage	470-490 V	---	528 V
Reverse Power	0	---	10%

Generator Breaker Settings (EZGN Genset Controller)	
Function	Setting
Gen Breaker Trip Setpoint (EZGN Rated Current)	600 A
Gen Breaker Level 1 (100%) Time Over Current	3 sec.
Gen Breaker Level 2 (120%) Time Over Current	1 sec.
Gen Breaker Level 3 (250%) Time Over Current	0.4 sec.

Feeder Breaker Settings (Feeder Protection Relay - FPR)	
Function (Note: Element 1 is the only active element)	Setting
T.O.C. Trip Pickup (amps) Note: 5A = 100% of CT rating	4.7
T.O.C. Curve Selection	U4
T.O.C. Time Dial	5.00
E.M Reset delay (Y/N)	N
Constant Time Adder (seconds)	0.00
Minimum Response Time (seconds)	0.00
Maximum Phase T.O.C. Torque Control	1

Radiator VFD Settings	
Function	Setting
Min PID Feedback	20
Max PID Feedback	240
rSL (Wake UP Threshold)	1
PID Reference Temperature	175°F
Proportional Gain	0.93
Integral Gain	0.3
Derivative	0
Minimum Speed	10 Hz.
Low Speed Timeout	10 sec.
Loss of Phase	Ignore

Charge Air Cooler VFD Settings	
Function	Setting
Min PID Feedback	20
Max PID Feedback	240
rSL (Wake UP Threshold)	Not Used
PID Reference Temperature	100°F
Proportional Gain	0.2
Integral Gain	0.1
Derivative	0

#### POWER PLANT GENERATION SWITCHGEAR OPERATION

THIS POWER PLANT IS DESIGNED TO OPERATE IN AUTOMATIC MODE UNDER CONTROL OF THE PROGRAMMABLE LOGIC CONTROLLER (PLC). MONITORING AND CONTROL IS PRIMARILY DONE THROUGH THE OPERATOR INTERFACE UNIT (OIU). IN AN EMERGENCY SUCH AS A FAILURE OF THE PLC IT CAN ALSO BE OPERATED IN MANUAL MODE. EACH ENGINE IS CONTROLLED BY AN INDIVIDUAL EASYGEN (EZGN) GENSET CONTROLLER LOCATED IN EACH GENERATOR SECTION. FOLLOWING ARE INSTRUCTIONS FOR OPERATING THE SYSTEM. SEE SECTION 3.1 OF THE O&M MANUAL FOR DETAILED SEQUENCES.

#### AUTOMATIC OPERATION:

- VERIFY THAT THE "SYSTEM MODE" SWITCH ON THE MASTER SECTION IS SET TO AUTO.
- CHECK THE MASTER SECTION FOR ANY FAULTS AS INDICATED BY THE ALARM LAMPS. CORRECT THE CAUSE OF THE FAULT (EMERGENCY STOP, LOW COOLANT LEVEL, FEEDER BREAKER TRIPPED, ETC.) PRESS THE ALARM RESET BUTTON ON THE MASTER SECTION AND VERIFY THAT THE ALARMS CLEAR.
- CHECK EACH GENERATOR SECTION FOR ANY FAULTS. FOR ENGINE-GENERATOR RELATED FAULTS CORRECT THE CAUSE OF THE FAULT (LOW OIL LEVEL, HIGH TEMPERATURE, CIRCUIT BREAKER TRIPPED, ETC.). TO CLEAR ANY ALARMS PRESS THE "ALARM RESET" BUTTON ON THE GENERATOR SECTION.
- PLACE EACH AVAILABLE GENERATOR IN SERVICE BY PRESSING THE "AUTO" BUTTON. IF A GENERATOR IS OUT OF SERVICE FOR REPAIR, VERIFY THE STOP BUTTON IS ILLUMINATED.
- THE PLC WILL AUTOMATICALLY START ALL GENERATORS IN AUTO AND PARALLEL THEM TO THE BUS. AS SOON AS THE BUS IS ENERGIZED THE STATION SERVICE POWER WILL TURN ON.
- AFTER THE AVAILABLE GENERATORS ARE ON LINE, THE PLC WILL WAIT FOR A BRIEF INTERVAL (USUALLY 15 SECONDS) AND CLOSE THE FEEDER BREAKER TO ENERGIZE THE COMMUNITY. THE RED BREAKER CLOSED LAMP WILL ILLUMINATE.

#### DEMAND CONTROL OPERATION (AUTO MODE):

- GENERATORS ARE CONSIDERED AVAILABLE FOR DEMAND CONTROL ONLY WHEN THEIR EZGN IS IN THE AUTO MODE AND THERE ARE NO ALARMS. THE DEMAND CONTROL SYSTEM WILL UTILIZE ALL AVAILABLE GENERATORS AS REQUIRED TO MEET THE LOAD ON THE SYSTEM.
- ON INITIAL STARTUP THE DEMAND CONTROL IS ACTIVATED AFTER THE FEEDER BREAKER HAS BEEN CLOSED FOR ONE MINUTE. THIS ALLOWS THE PLC TIME TO DETERMINE THE POWER DEMAND ON THE SYSTEM. THE PLC MONITORS THE LOAD ON THE SYSTEM AND COMPARES IT TO THE CONNECTED GENERATING CAPACITY.
- THE DEMAND CONTROL PROVIDES TWO TYPES OF CONTROL FOR INCREASING LOAD – INCREASE AND OVERLOAD. THE OVERLOAD SETPOINT IS TYPICALLY THE PRIME RATING OF THE GENSET AND THE INCREASE SETPOINT IS TYPICALLY 90% OF THE OVERLOAD SETPOINT. WHEN THE LOAD EXCEEDS THE INCREASE SETPOINT FOR A PRE-SET TIME DELAY (USUALLY 30 SECONDS) THE DEMAND CONTROL WILL SWITCH TO THE NEXT HIGHER LEVEL OF GENERATING CAPACITY. WHEN THE LOAD EXCEEDS THE OVERLOAD SETPOINT THE DEMAND CONTROL WILL IMMEDIATELY SWITCH TO THE NEXT HIGHER LEVEL OF GENERATING CAPACITY (NO TIME DELAY).
- THE DEMAND CONTROL PROVIDES ONE TYPE OF CONTROL FOR DECREASING LOAD. THE DECREASE SETPOINT IS TYPICALLY 80% OF THE OVERLOAD SETPOINT. WHEN THE LOAD DROPS BELOW THE DECREASE SETPOINT FOR A PRE-SET TIME DELAY (USUALLY 2 MINUTES) THE DEMAND CONTROL WILL SWITCH TO THE NEXT LOWER LEVEL OF GENERATING CAPACITY.
- NOTE THAT ALL GENERATORS ARE EQUAL CAPACITY AND THE OPERATOR MUST SELECT A PRIORITY LEVEL FOR EACH GENERATOR USING THE SCADA SYSTEM.
- SEE THE DEMAND CONTROL TABLE THIS SHEET FOR DEMAND LEVEL SETPOINTS AT THE TIME OF COMMISSIONING. ON THE SCADA SYSTEM GO TO THE DEMAND TAB TO VERIFY THE PRESENT SETPOINTS.

#### MANUAL OPERATION:

- PLACE THE MASTER CONTROL "SYSTEM MODE" SWITCH IN THE MANUAL POSITION.
- CHECK THE MASTER AND GENERATOR SECTIONS FOR ANY FAULTS AND CLEAR AS DESCRIBED UNDER AUTOMATIC OPERATION STEPS 2 AND 3.
- TO PLACE A GENERATOR IN SERVICE, PRESS THE EZGN MAN BUTTON, THEN PRESS THE "I" (START) BUTTON. AFTER THE ENGINE STARTS AND STABILIZES, PRESS THE CONTACTOR CLOSE BUTTON ON THE EZGN. THE RED BREAKER CLOSED LAMP WILL ILLUMINATE.
- REPEAT THIS PROCESS FOR AT LEAST ONE MORE GENERATOR.
- WITH TWO GENERATORS ON LINE ROTATE THE FEEDER BREAKER CONTROL KNOB FOR THE MAIN FEEDER BREAKER TO THE CLOSE POSITION TO ENERGIZE THE COMMUNITY. MONITOR THE LOAD ON THE SYSTEM FOR ONE MINUTE THEN SELECT THE APPROPRIATE GENERATOR(S) TO MATCH THE LOAD.
- TAKE ANY GENERATOR(S) NOT NEEDED OFF LINE BY PRESSING THE RED EZGN STOP BUTTON. THE ENGINE WILL COOL DOWN FOR THREE MINUTES THEN SHUT OFF. NOTE THAT PRESSING THE RED STOP BUTTON TWICE WILL IMMEDIATELY SHUT DOWN THE GENERATOR.
- TO MANUALLY ADD A SECOND GENERATOR TO MEET AN INCREASING LOAD, REPEAT STEP 3. TO MANUALLY REMOVE A SECOND GENERATOR TO MEET A DECREASING LOAD, REPEAT STEP 6.

#### SERVICE DUE / OIL CHANGE PROCEDURE:

NOTE THAT UNDER AUTOMATIC OPERATION, WHENEVER THE SERVICE TIME HAS BEEN EXCEEDED THE GENERATOR WILL AUTOMATICALLY BE TAKEN OFF LINE AS LONG AS ANOTHER GENERATOR IS AVAILABLE IN AUTO. AN "ENGINE SERVICE" MESSAGE WILL DISPLAY ON THE EZGN AND THE RED "ENGINE ALARM" LAMP WILL ILLUMINATE.

- IF THE SWITCHGEAR IS IN MANUAL MODE, PERFORM MANUAL OPERATION STEPS 3 AND 6 ABOVE THEN CONTINUE AT STEP 3 BELOW (LOCK OUT).
- IF THE SWITCHGEAR IS IN AUTOMATIC MODE, PRESS THE EZGN MAN BUTTON ON THE GENERATOR TO BE SERVICED. THE PLC WILL START ANOTHER GENERATOR. ONCE THE OTHER GENERATOR IS ON LINE, PRESS THE EZGN STOP BUTTON ON THE GENERATOR TO BE SERVICED. NOTE THAT IF THE STOP BUTTON IS PRESSED BEFORE ANOTHER UNIT IS ONLINE, AN OUTAGE WILL OCCUR.
- LOCK THE UNIT OUT USING THE KEY SWITCH AND TAG OUT OF SERVICE.
- SERVICE ENGINE (OIL CHANGE, FUEL FILTER, AIR FILTER, ETC.).
- REMOVE TAG AND TURN THE GENERATOR LOCKOUT SWITCH TO RUN.
- PRESS THE "SERVICE HOURS RESET" BUTTON AND HOLD FOR 10 SECONDS.
- PRESS THE "ALARM RESET" BUTTON.
- AFTER ALL ALARMS HAVE BEEN CLEARED PRESS THE "HOME" BUTTON.
- START THE ENGINE BY PRESSING THE MAN BUTTON AND THEN "I" (START) BUTTON.
  - AFTER THE ENGINE COMES UP TO SPEED VERIFY THAT THE ENGINE OIL PRESSURE IS IN THE NORMAL RANGE.
  - CHECK THE OIL FILTER FOR LEAKS.
- AFTER THE ENGINE RUNS FOR ONE MINUTE PRESS THE STOP BUTTON.
- CHECK THE OIL LEVEL USING THE DIPSTICK AND ADD OIL AS REQUIRED.
- PLACE THE GENERATOR BACK IN SERVICE BY PRESSING THE AUTO BUTTON ON THE EZGN.

#### ENGINE-GENERATOR PROTECTION ALARMS:

SEE THE TABLES THIS SHEET FOR ALARM LEVEL SETPOINTS AND BREAKER TRIP SETTINGS AT THE TIME OF COMMISSIONING. SEE SECTION 3.1 OF THE O&M MANUAL FOR DETAILED DESCRIPTIONS OF WARNING ALARM AND PROTECTION SEQUENCES.

#### FUEL/OIL SYSTEM

AUTOMATIC DAY TANK FILL – THE 200 GALLON DAY TANK IS FILLED FROM THE BULK TANKS IN THE ADJACENT TANK FARM INTERMEDIATE TANK. IT HAS AUTOMATIC FILL CONTROLS WITH REDUNDANT HIGH AND LOW LEVEL ALARMS AND TIMERS. SEE FUEL SYSTEM CONTROL PANEL DRAWING SHEET E7.3 FOR DETAILED SEQUENCE OF OPERATION.

DAY TANK FILTER – THE DAY FILTER HAS WATER DETECTION PROBES. AN ALARM LAMP WILL ILLUMINATE WHEN WATER IS PRESENT IN THE FUEL. SEE WATER INDICATION PANEL DRAWING SHEET E7.4.

MANUAL USED ENGINE OIL DRAIN – USED OIL PUMP P-U01 IS USED TO PUMP USED ENGINE OIL FROM THE ENGINE OIL PANS TO THE USED OIL HOPPER. P-U01 RUNS THROUGH A MANUAL 0-5 MINUTE TIMER SWITCH.

AUTOMATIC USED ENGINE OIL BLENDING SYSTEM – THE USED ENGINE OIL BLENDING SYSTEM FILTERS USED OIL AND MIXES IT WITH DIESEL FUEL IN THE DAY TANK TO BE BURNED BY THE ENGINES. THE PUMPING RATES ARE SET TO BLEND APPROXIMATELY 0.5% USED OIL TO 99.5% DIESEL FUEL. NOTE THAT WHEN THERE IS NO USED OIL IN THE HOPPER THE DIESEL PUMP STILL RUNS TO USE THE BLENDER AS A FUEL "POLISHING" FILTER. SEE FUEL SYSTEM CONTROL PANEL DRAWING SHEET E7.3 FOR DETAILED SEQUENCE OF OPERATION.

#### ENGINE COOLING SYSTEM

CHARGE AIR COOLERS (CAC) – CAC FANS WILL OPERATE CONTINUOUSLY ANY TIME ASSOCIATED ENGINE RUNS AND STOP WHEN THE ENGINE STOPS. VARIABLE FREQUENCY DRIVES WILL OPERATE AT FULL SPEED FOR 30 SECONDS UPON STARTUP AND THEN WILL MODULATE FAN SPEED TO MAINTAIN ENGINE INTAKE MANIFOLD AIR TEMPERATURE OPERATING SETPOINT. SEE THE RADIATOR VFD SETTINGS TABLE THIS SHEET FOR SETPOINTS AT THE TIME OF COMMISSIONING.

RADIATORS – RADIATOR FAN MOTORS WILL OPERATE UNDER VARIABLE FREQUENCY DRIVE (VFD) CONTROL. WHEN THE COOLANT RETURN TEMP REACHES THE PID REFERENCE SETPOINT THE MOTOR WILL START AT MINIMUM SPEED AND RAMP UP TO THE REQUIRED SPEED. USING PID CONTROL, THE VFD WILL MODULATE THE FAN SPEED AS REQUIRED TO MAINTAIN COOLANT RETURN TEMP AT THE PID REFERENCE SETPOINT. AS THE COOLANT RETURN TEMP RISES, THE VFD WILL INCREASE THE SPEED OF THE FAN MOTOR UP TO 100%. ONCE THE FAN REACHES THE MINIMUM SPEED, THE VFD WILL MAINTAIN THAT SPEED UNTIL THE LOW SPEED TIME OUT EXPIRES. WHEN THE LOW SPEED TIME OUT EXPIRES THE MOTOR WILL STOP. THE MOTOR WILL REMAIN OFF UNTIL THE COOLANT RETURN TEMP RISES TO THE PID REFERENCE SETPOINT. SEE THE RADIATOR VFD SETTINGS TABLE THIS SHEET FOR SETPOINTS AT THE TIME OF COMMISSIONING.

THERMOSTATIC VALVE TV-1 WILL MIX HOT COOLANT FROM THE ENGINE DISCHARGE PIPE WITH COLD COOLANT FROM THE RADIATOR RETURN PIPE TO MAINTAIN 175°F +/- TEMPERATURE COOLANT RETURN TO THE ENGINES.

ENGINE COOLANT RETURN HIGH TEMPERATURE ALARM. WHEN THE ENGINE COOLANT RETURN TEMPERATURE RISES ABOVE 190°F FOR A MINIMUM OF 2 MINUTES, THE "HIGH COOLANT RETURN TEMPERATURE" LAMP SHALL ILLUMINATE. LAMP SHALL REMAIN ON UNTIL MASTER RESET BUTTON IS PRESSED.

#### POWER PLANT HEATING AND VENTILATION SYSTEM

GENERATION ROOM – THE OPERATING AND OFF LINE GENERATORS REJECT MORE HEAT TO THE GENERATION ROOM THAN IS REQUIRED SO EXHAUST FANS WITH INTAKE AIR DUCTS ARE INSTALLED TO PROVIDE COOLING.

GENERATION ROOM VENTILATION – THERE ARE FOUR AIR INTAKES IN THE GENERATION ROOM CEILING. ONE OF THE AIR INTAKES IS USED FOR COMBUSTION AIR AND THE DAMPER IS OPEN ANY TIME THE STATION SERVICE POWER IS ON. THE OTHER THREE AIR INTAKES ARE LABELED "EF-1" "EF-2" AND "EF-3". THESE DAMPERS OPEN WHENEVER THE ASSOCIATED EXHAUST FAN RUNS. THE INTAKES ARE EQUIPPED WITH A MOTORIZED DAMPER THAT OPENS EACH TIME THE ASSOCIATED EXHAUST FAN RUNS.

EXHAUST FANS – THERE ARE THREE EXHAUST FANS ON THE WALL ABOVE THE FRONT OF THE GENERATORS, EF-1 EF-2 AND EF-3. EACH FAN IS EQUIPPED WITH A MOTORIZED DAMPER THAT OPENS WHENEVER THE FAN RUNS ON A CALL FOR COOLING THROUGH A 24VAC DIGITAL MODULATING THERMOSTAT. THE THERMOSTAT WILL PROVIDE A 0-10V SIGNAL TO MODULATE THE FAN SPEED AS REQUIRED TO MAINTAIN GENERATING ROOM TEMP, 80F, ADJUSTABLE.

MOTOR OPERATED DAMPERS – ALL DAMPER MOTORS WILL BE NORMALLY CLOSED SPRING RETURN AND WILL CLOSE ON LOSS OF POWER (FIRE ALARM) IN LESS THAN 30 SECONDS. VENTILATION AIR INTAKE AND EXHAUST MOTORIZED DAMPERS WILL OPEN ANY TIME THE ASSOCIATED EXHAUST FAN OPERATES. THE COMBUSTION AIR INTAKE MOTORIZED DAMPER WILL BE OPEN ANY TIME PLANT OPERATES (STATION SERVICE POWER ON).

CONTROL ROOM VENTILATION – COOLING AND VENTILATION FOR THE CONTROL ROOM IS PROVIDED BY AN OPERABLE WINDOW.

CONTROL ROOM HEATING – THE CONTROL ROOM IS HEATED BY A CABINET UNIT HEATER. PUMP P-CUH1 CIRCULATES ENGINE COOLANT FROM THE PIPING MAINS THROUGH THE CABINET UNIT HEATER IN THE CONTROL ROOM. THE TEMPERATURE CONTROLLER ON THE HEATER CYCLES THE PUMP AND THE HEATER FAN ON AND OFF AS REQUIRED TO MAINTAIN TEMPERATURE IN THE CONTROL ROOM, 65 F, ADJUSTABLE.

#### HEAT RECOVERY SYSTEM

THE POWER PLANT HEAT EXCHANGER (HX-1), THE PRIMARY (HOT SIDE) ENGINE COOLANT CIRCULATING PUMP (P-HR1A), AND THE SECONDARY (COLD SIDE) HEAT RECOVERY FLUID MAIN CIRCULATING PUMP (P-HR1B) ARE LOCATED IN THE POWER PLANT. BOTH PUMPS OPERATE CONTINUOUSLY UNDER MANUAL CONTROL.

PEX ARCTIC PIPE TEMPERING SYSTEM – THE HEAT RECOVERY ARCTIC PIPE IS PEX (PLASTIC) PIPE WHICH HAS A LIMITED LIFE AT ELEVATED TEMPERATURES. THE HEAT RECOVERY SUPPLY TEMPERATURE IS TEMPERED BY A THREE-WAY THERMOSTATIC VALVE "TV-2" THAT IS INSTALLED BETWEEN THE HEAT EXCHANGER AND THE ARCTIC PIPE. THE VALVE MIXES COLD RETURN FLUID WITH HOT FLUID FROM THE HEAT EXCHANGER TO LIMIT THE SUPPLY TEMPERATURE TO APPROXIMATELY 185F.

HEAT RECOVERY LOSS OF PRESSURE – WHEN THE SYSTEM PRESSURE IN THE HEAT RECOVERY PIPING DROPS BELOW 15 PSIG FOR 15 MINUTES, A RED LAMP "HEAT RECOVERY LOSS OF PRESSURE" LOCATED IN THE SWITCHGEAR MASTER SECTION WILL ILLUMINATE.

NO LOAD ON HEAT RECOVERY SYSTEM – WHEN THE HEAT RECOVERY RETURN TEMP. IS EQUAL TO OR GREATER THAN THE HEAT RECOVERY SUPPLY TEMP. FOR 60 MINUTES, AN AMBER LAMP "NO LOAD ON HEAT RECOVERY" LOCATED IN THE SWITCHGEAR MASTER SECTION WILL ILLUMINATE. WHEN THE HEAT RECOVERY SUPPLY TEMP. IS A MIN. OF 1°F GREATER THAN THE HEAT RECOVERY RETURN TEMP. THE LAMP WILL TURN OFF.

HEAT RECOVERY LOSS OF FLOW – WHEN THE FLOW RATE IN THE HEAT RECOVERY PIPING FALLS BELOW 10 GPM FOR 15 MINUTES, A RED LAMP "HEAT RECOVERY LOSS OF FLOW" LOCATED IN THE SWITCHGEAR MASTER SECTION WILL ILLUMINATE.

THE HEAT RECOVERY SYSTEM PROVIDES INTERRUPTIBLE HEAT TO ADJACENT BUILDINGS IN THE COMMUNITY AS SHOWN ON SHEET M8.1.

#### SYSTEM STARTUP

FUEL OIL PUMPS – PRIOR TO STARTING FUEL AND OIL PUMPS PRIME CAVITIES WITH LUBE OIL AND RUN MOMENTARILY TO VERIFY CORRECT ROTATION.

FUEL OIL PIPING – AFTER PRESSURE TESTING FILL ALL FILTER BODIES, PRIME ALL PIPING, AND BLEED OFF AIR.

VERIFY OPERATION OF ALL FUEL SYSTEM CONTROLS IN ACCORDANCE WITH SEQUENCES OF OPERATION ON THE CONTROL PANEL DRAWINGS.

ENGINE COOLANT PIPING – AFTER PRESSURE TESTING, FLUSHING, AND BLEEDING, FILL SYSTEM WITH ETHYLENE GLYCOL SOLUTION. SEE HYDRONIC PIPING SPECIFICATION 23 21 13.

HEAT RECOVERY PIPING – AFTER PRESSURE TESTING, FLUSHING, AND BLEEDING, FILL SYSTEM WITH PROPYLENE GLYCOL SOLUTION. SEE HYDRONIC PIPING SPECIFICATION 23 21 13.

VERIFY OPERATION AND CALIBRATION OF ENGINE COOLANT SYSTEM AND HEAT RECOVERY SYSTEM THERMOSTATIC VALVES.

VERIFY PROPER OPERATION OF THERMOMETERS, PRESSURE GAUGES, AND ELECTRICAL INSTRUMENTATION DEVICES. SET SWITCHES ON DIFFERENTIAL PRESSURE GAUGES TO SETPOINTS INDICATED. CALIBRATE THERMOMETERS AND ALL ELECTRICAL INSTRUMENTATION DEVICES INCLUDING TEMPERATURE TRANSMITTERS, PRESSURE TRANSMITTERS, DIFFERENTIAL PRESSURE SWITCHES, FLOW METERS, ENERGY METERS, LEVEL GAUGES, ETC. SEE INSTRUMENTATION AND CONTROL DEVICES SPECIFICATION 23 09 00.

CLEAN ALL PIPING STRAINERS AFTER FIRST 48 HOURS OR MORE OF OPERATION. MONITOR SYSTEM OPERATION FOR ONE WEEK MINIMUM BEFORE LEAVING SITE. CHANGE GLYCOL FILTER ELEMENTS AT TIME OF FIRST OIL CHANGE ON EACH ENGINE.

**INITIAL TESTING WAS PERFORMED AS PART OF THE MODULE ASSEMBLY CONTRACT. FINAL SYSTEM STARTUP, TESTING, AND COMMISSIONING IS INCLUDED IN THE ON SITE SCOPE.**

ISSUED FOR  
CONSTRUCTION  
JULY 2022

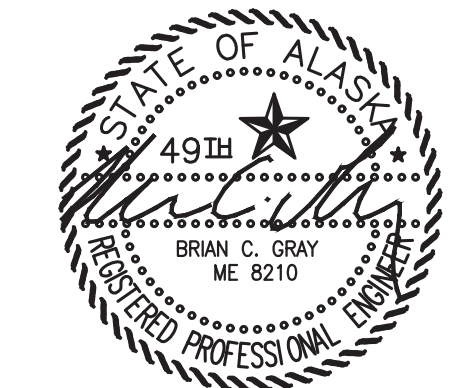

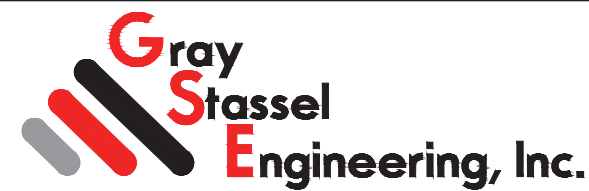
 <b>ALASKA ENERGY AUTHORITY</b>		
PROJECT: <b>NAPASKIAK POWER SYSTEM UPGRADE</b>		
TITLE: <b>SYSTEM START UP &amp; SEQUENCE OF OPERATIONS</b>		
 P.O. 111405, Anchorage, AK 99511 (907)349-0100	DRAWN BY: JTD DESIGNED BY: BCG FILE NAME: NAPS PP M1 PROJECT NUMBER:	SCALE: AS NOTED DATE: 7/29/22 SHEET: <b>M1.3</b>

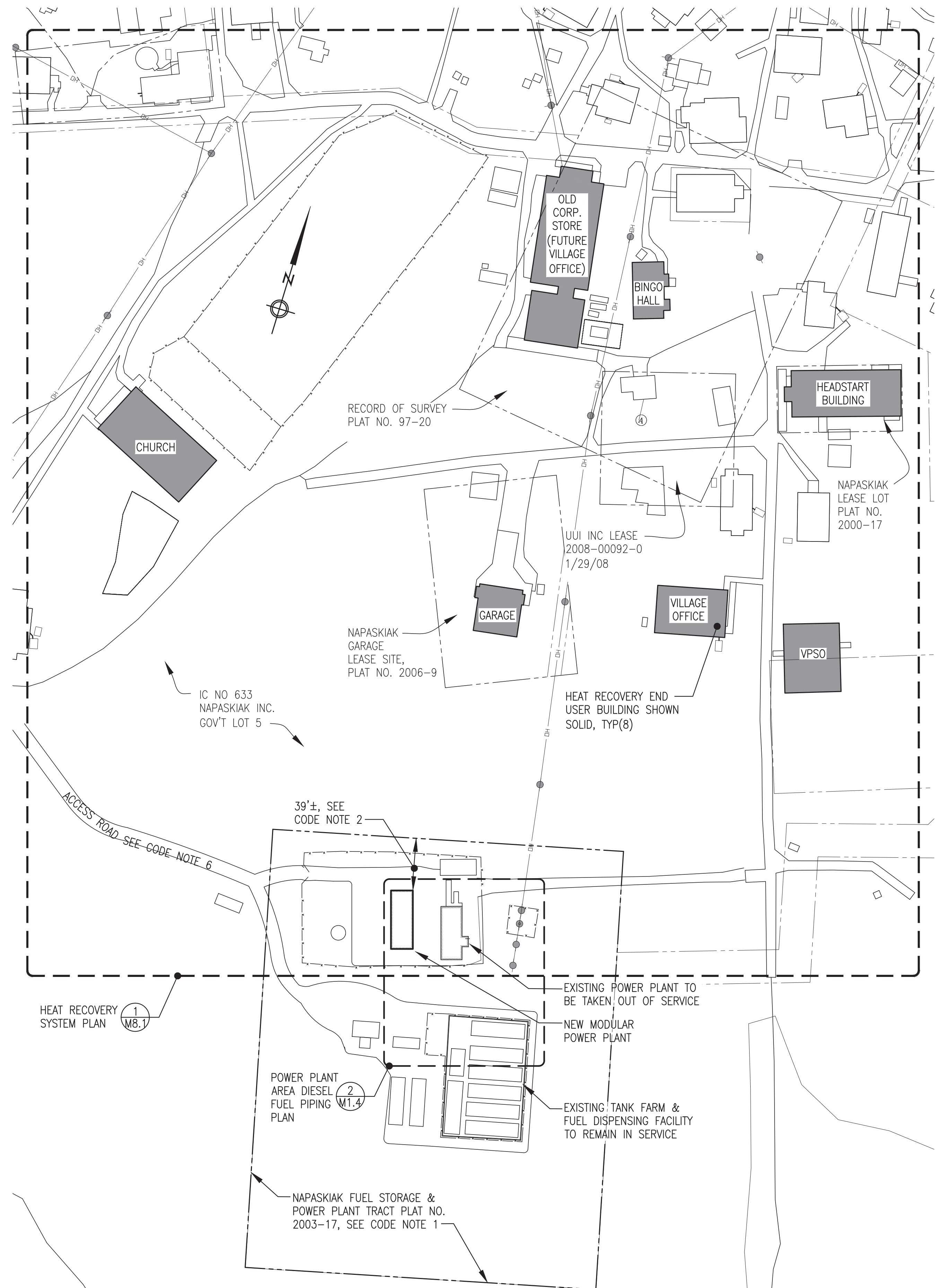

**1 OVERALL POWER PLANT & HEAT RECOVERY VICINITY PLAN**  
 M1.4 1"=50'

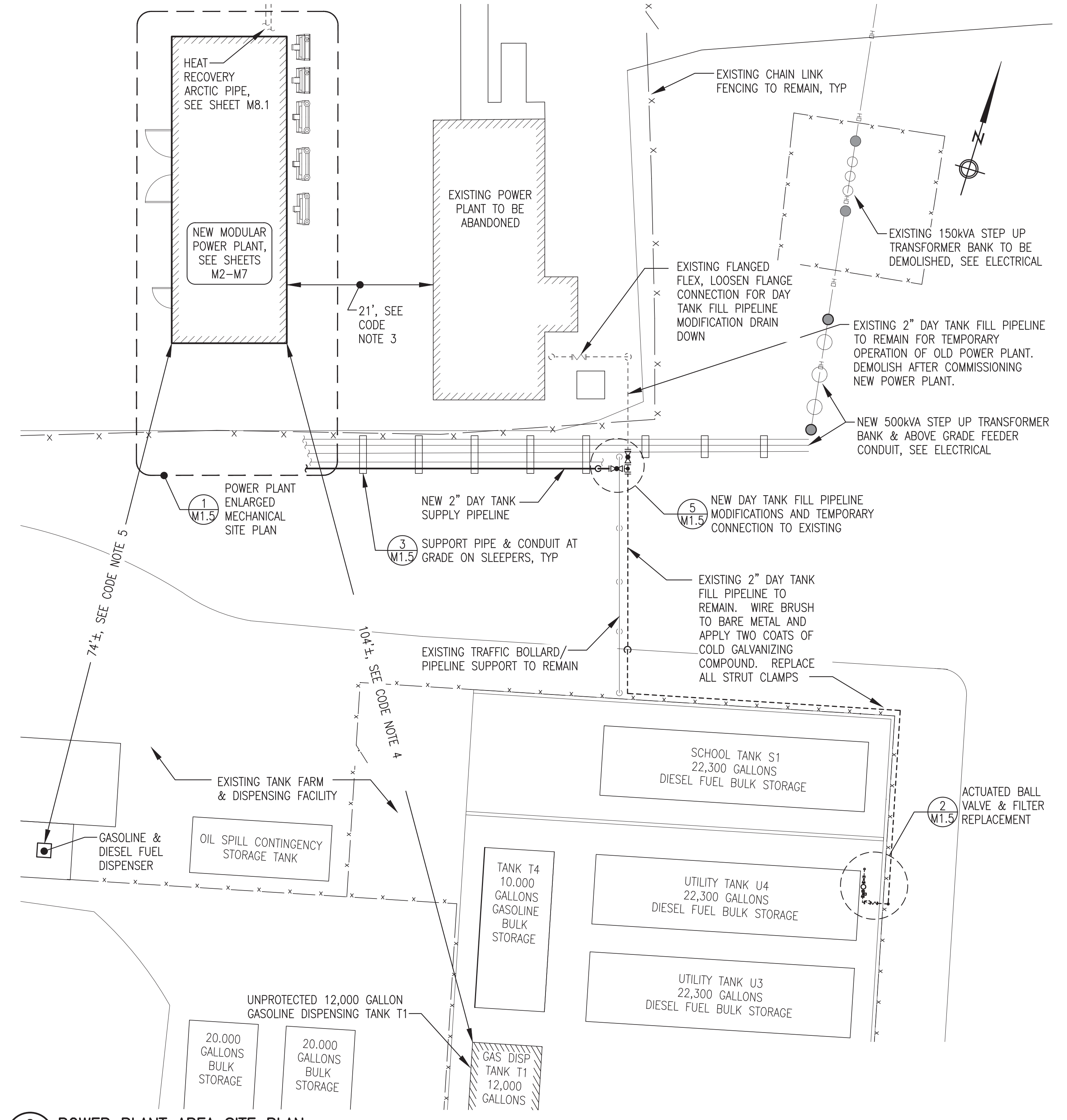

**2 POWER PLANT AREA SITE PLAN**  
 M1.4 1"=10'

- SITE LAYOUT CODE NOTES**
- 1) THE NEW NAPASKIAK POWER PLANT IS LOCATED ON THE SAME PARCEL OF LAND AS THE EXISTING POWER PLANT AND THE NAPASKIAK BULK FUEL STORAGE AND DISPENSING FACILITY, PLAT NO. 2003-17.
  - 2) THE IBC REQUIRES 10' MINIMUM CLEARANCE FROM THE POWER PLANT TO THE NEAREST PROPERTY LINE WHICH IS OR CAN BE BUILT UPON, SEE CODE ANALYSIS ON SHEET A1. THE NEW POWER PLANT WILL BE LOCATED MORE THAN 35' FROM THE NEAREST PROPERTY LINE.
  - 3) THE NEW POWER PLANT IS CLASSIFIED F-1. THE EXISTING POWER PLANT WILL LIKELY BE USED IN THE FUTURE FOR COLD STORAGE AS EITHER S-1 OR S-2. AN IMAGINARY PROPERTY LINE IS ASSUMED AT 10' FROM THE OLD POWER PLANT SO THE NEW POWER PLANT WILL BE MORE THAN 10' FROM THIS LINE.
  - 4) THE IFC REQUIRES 50' MINIMUM CLEARANCE FROM THE EXISTING UNPROTECTED DISPENSING TANK TO THE NEAREST IMPORTANT BUILDING. THE NEW POWER PLANT WILL BE LOCATED MORE THAN 100' FROM THE DISPENSING TANK.
  - 5) THE IFC REQUIRES 10' MINIMUM CLEARANCE FROM THE DISPENSER TO BUILDINGS NOT HAVING 1-HOUR FIRE RESISTANCE. THE NEW POWER PLANT WILL BE LOCATED MORE THAN 70' FROM THE DISPENSER.
  - 6) THE IFC REQUIRES FIRE APPARATUS ROADWAY ACCESS TO WITHIN 150' OF EVERY PORTION OF THE FACILITY. THE EXISTING ACCESS ROAD AND EARTHEN PAD PROVIDES ACCESS TO WITHIN 25' OF ALL PORTIONS OF THE NEW POWER PLANT.

**ALL WORK ON THIS SHEET IS INCLUDED IN THE ON SITE CONTRACT.**

**ISSUED FOR CONSTRUCTION DECEMBER 2022**



**ALASKA ENERGY AUTHORITY**

PROJECT: **NAPASKIAK POWER SYSTEM UPGRADE**

TITLE: **POWER PLANT & HEAT RECOVERY VICINITY PLAN, SITE PLAN, & DETAILS**

<p><b>Gray Stassel Engineering, Inc.</b>        P.O. 111405, Anchorage, AK 99511 (907)349-0100</p>	DRAWN BY: JTD	SCALE: AS NOTED
	DESIGNED BY: BCG	DATE: 12/15/22
	FILE NAME: NAPS PP M1	SHEET:
	PROJECT NUMBER:	<b>M1.4</b>

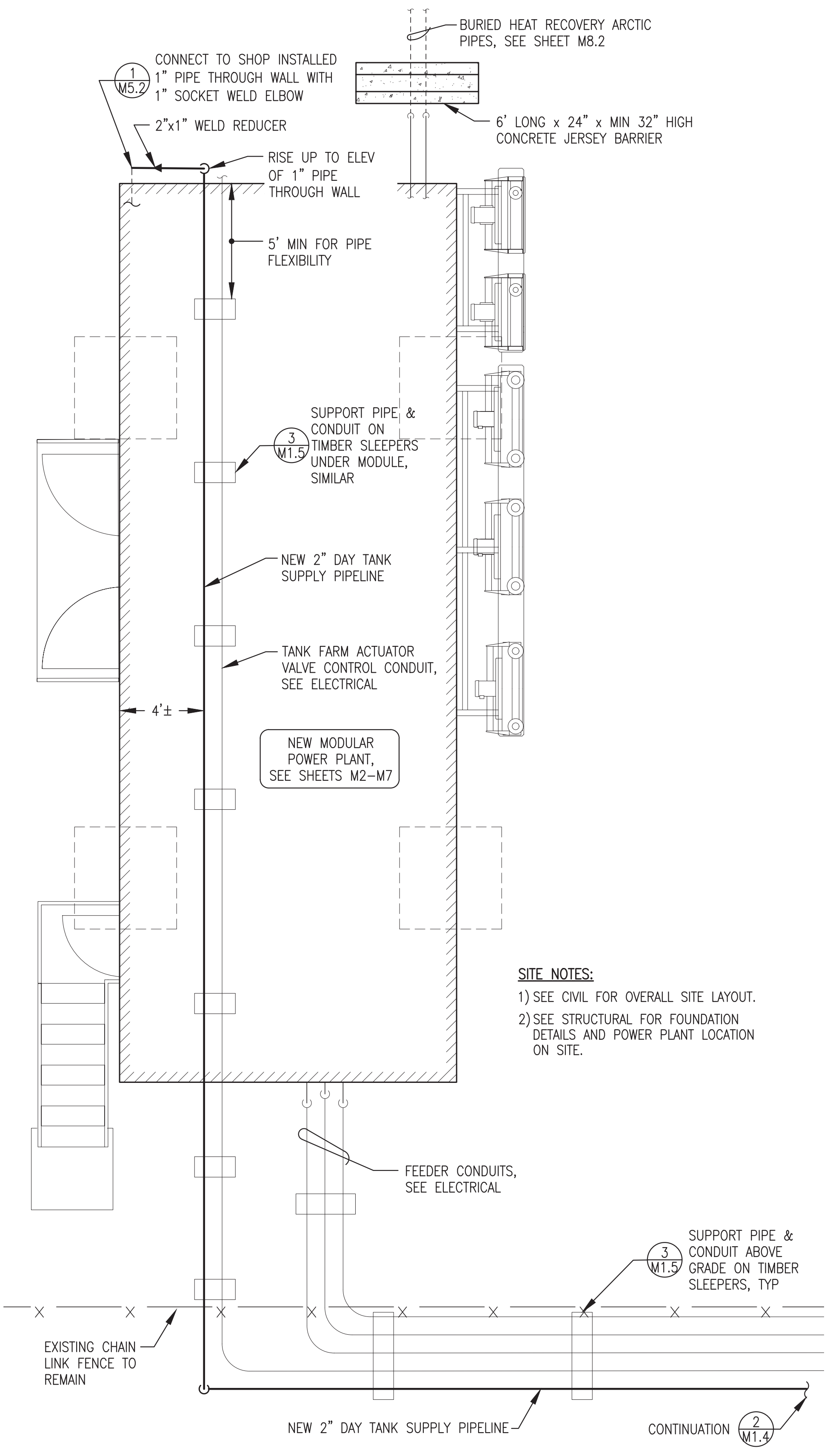

**SITE NOTES:**  
 1) SEE CIVIL FOR OVERALL SITE LAYOUT.  
 2) SEE STRUCTURAL FOR FOUNDATION DETAILS AND POWER PLANT LOCATION ON SITE.

**1 POWER PLANT ENLARGED MECHANICAL SITE PLAN**  
 M1.5 1/4"=1'-0"

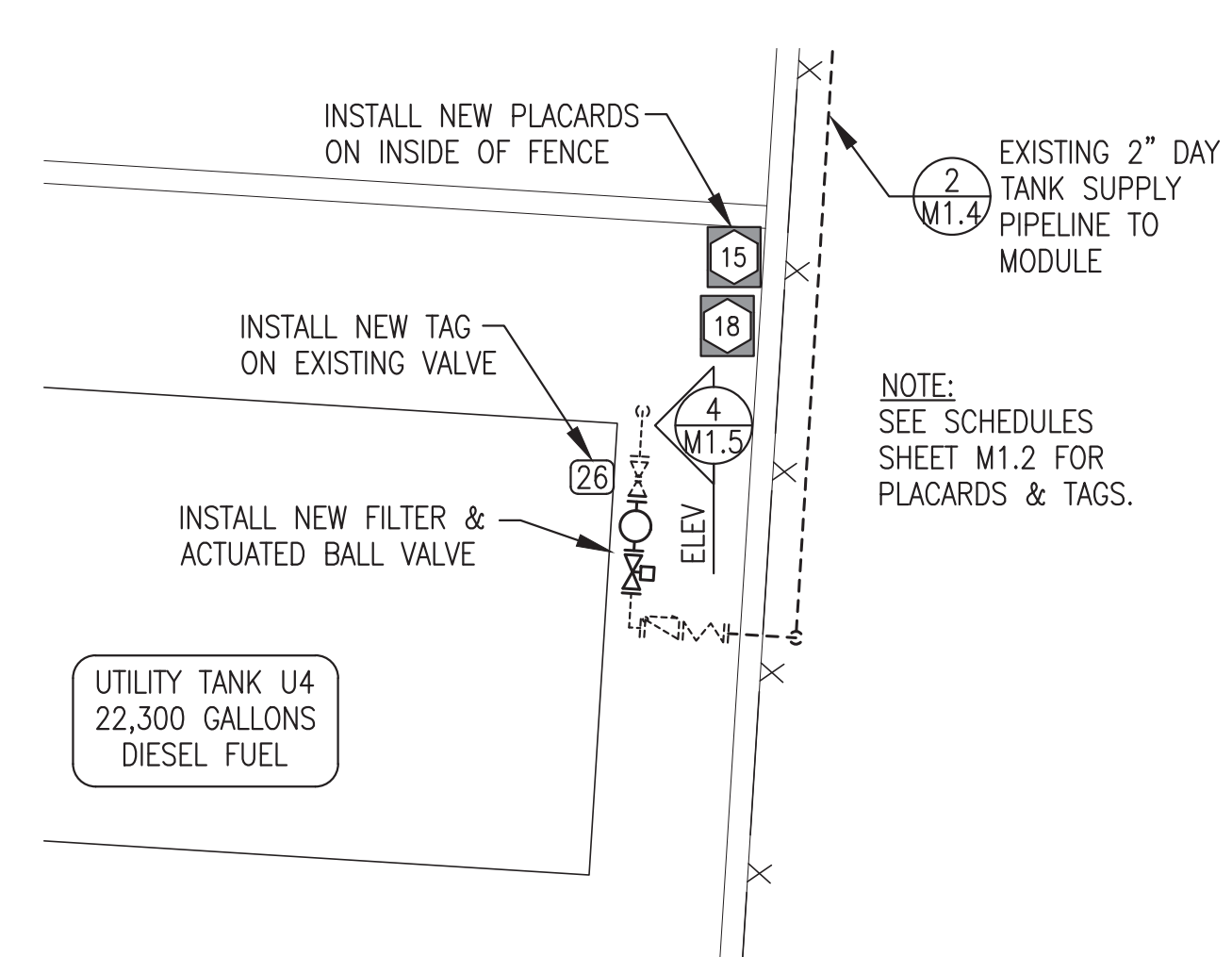

**2 ACTUATED BALL VALVE & FILTER REPLACEMENT PLAN**  
 M1.5 1/4"=1'-0"

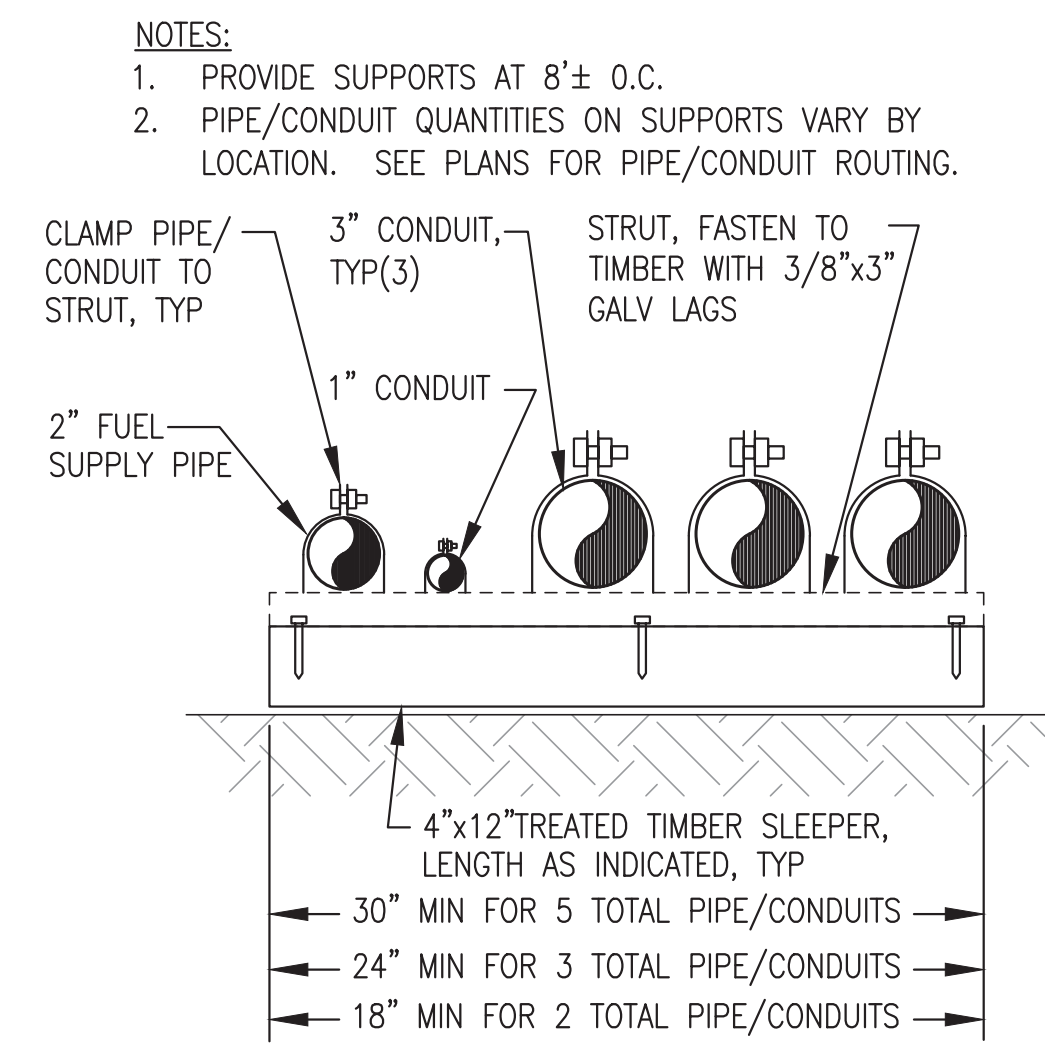

**3 PIPE/CONDUIT SLEEPER SUPPORT**  
 M1.5 NO SCALE

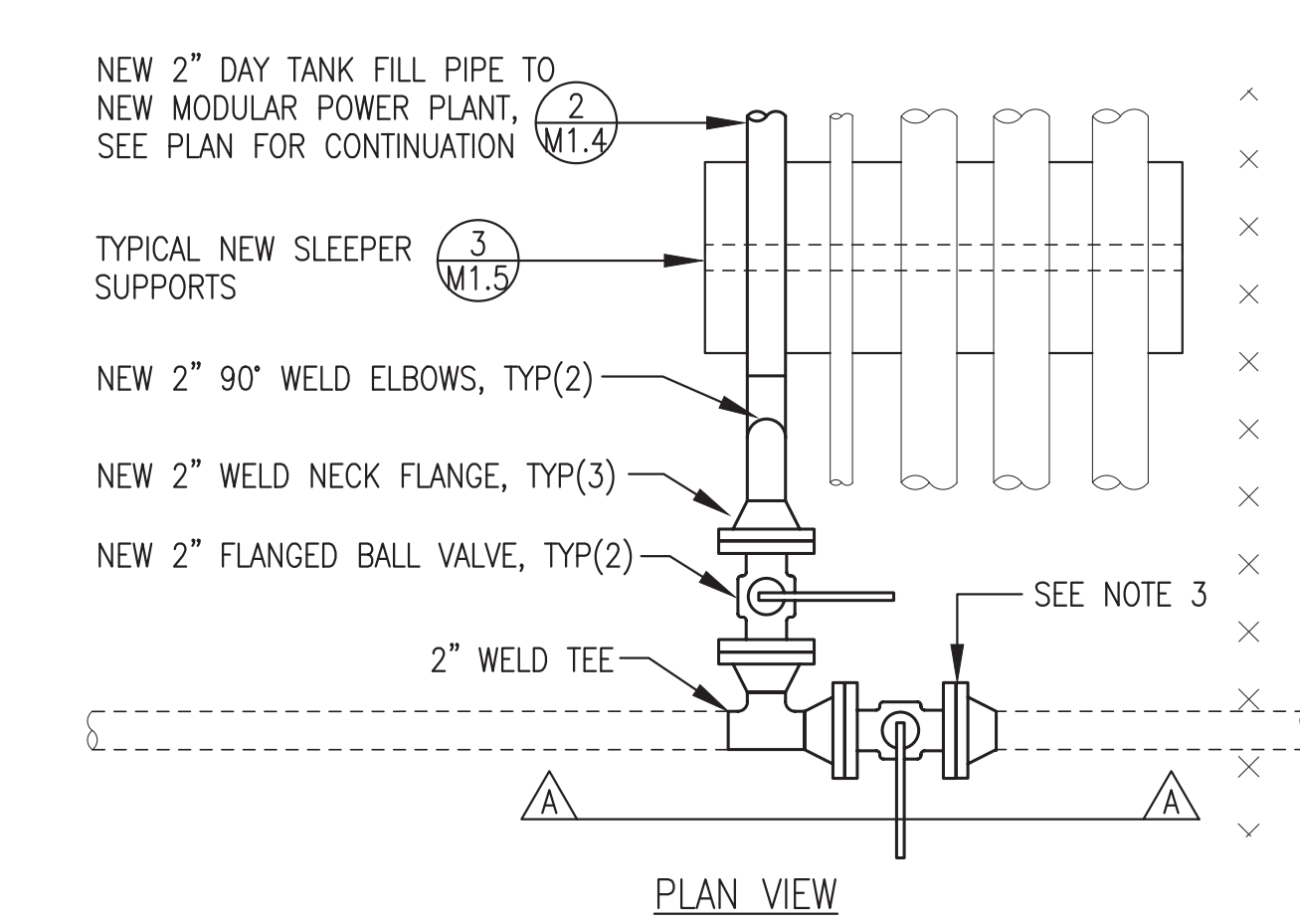
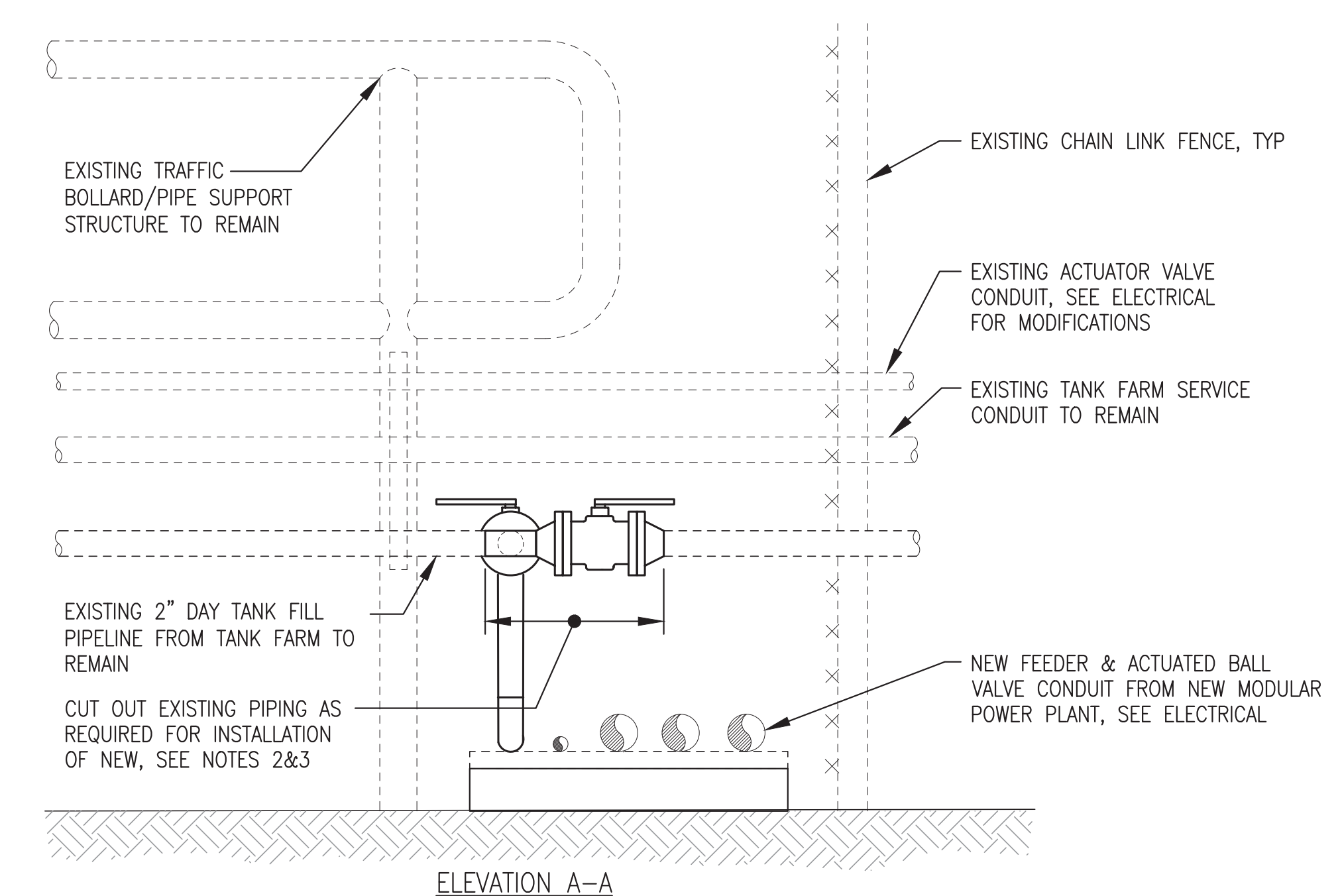

**NOTES:**  
 1. ALL NEW & EXISTING PIPE 2" SCH 80. NEW 2" PIPE & FITTINGS SHOWN WITH DARK, SOLID LINES. EXISTING PIPE & FITTINGS TO REMAIN SHOWN WITH LIGHT, DASHED LINES.  
 2. PRIOR TO MODIFYING PIPING, ENSURE THAT DAY TANK IN OLD POWER PLANT IS FULL. TURN OFF DAY TANK PANEL & DRAIN PIPE BY LOOSENING FLANGE AT FLEX CONNECTOR LOCATED NEAR THE OLD POWER PLANT.  
 3. INERT PIPE PRIOR TO CUTTING & PERFORM ALL WELDING IN ACCORDANCE WITH APPROPRIATE HOT WORK PROCEDURES PER NFPA 51B.  
 4. AFTER NEW PLANT IS COMMISSIONED CLOSE VALVE, DRAIN & REMOVE PIPING BEYOND THIS JOINT, REMOVE HANDLE, & INSTALL BLIND FLANGE.

**5 NEW DAY TANK FILL PIPELINE CONNECTION TO EXISTING**  
 M1.5 NO SCALE

**NOTES:**  
 1. PROVIDE SUPPORTS AT 8'± O.C.  
 2. PIPE/CONDUIT QUANTITIES ON SUPPORTS VARY BY LOCATION. SEE PLANS FOR PIPE/CONDUIT ROUTING.

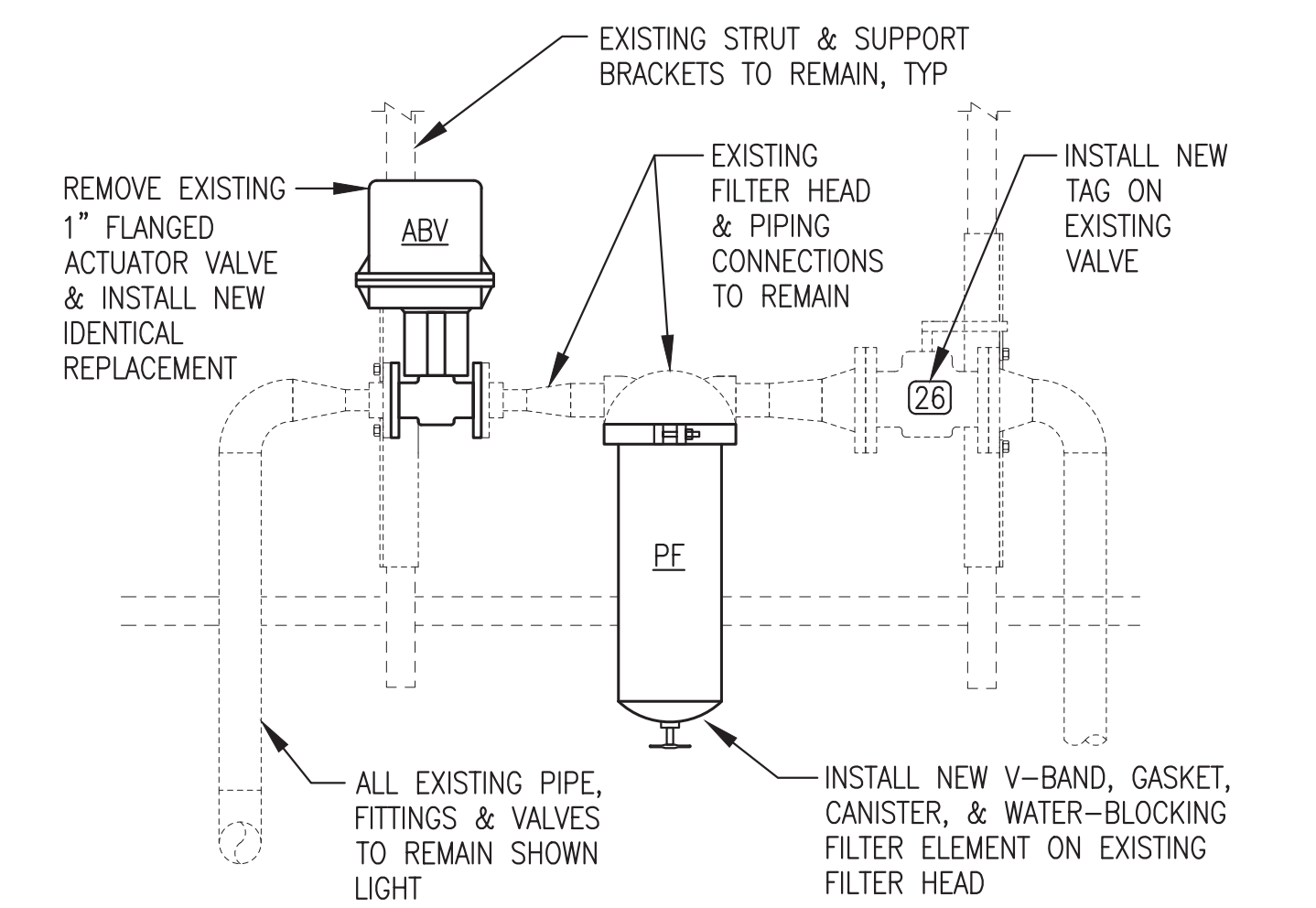

**4 ACTUATED BALL VALVE & FILTER REPLACEMENT ELEVATION**  
 M1.5 NO SCALE

**ALL WORK ON THIS SHEET IS INCLUDED IN THE ON SITE CONTRACT.**

ISSUED FOR CONSTRUCTION  
 DECEMBER 2022

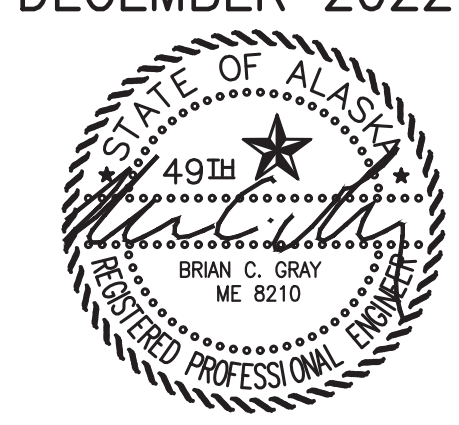

PROJECT: NAPASKIAK POWER SYSTEM UPGRADE	
TITLE: POWER PLANT ENLARGED MECHANICAL SITE PLAN & DETAILS	
DRAWN BY: JTD	SCALE: AS NOTED
DESIGNED BY: BCG	DATE: 12/15/22
FILE NAME: NAPS PP M1	SHEET: M1.5
PROJECT NUMBER:	
P.O. 111405, Anchorage, AK 99511 (907)349-0100	

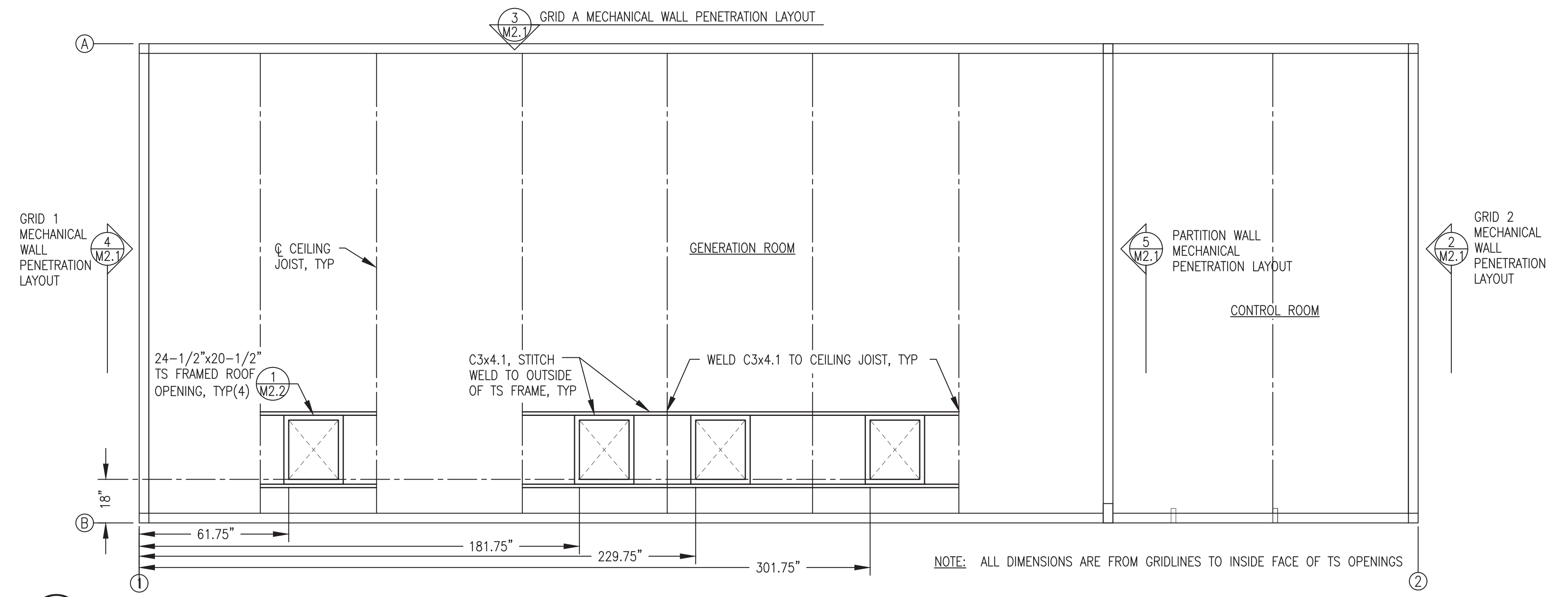

1 MECHANICAL PENETRATION LAYOUT & ROOF PLAN  
3/8"=1'-0"

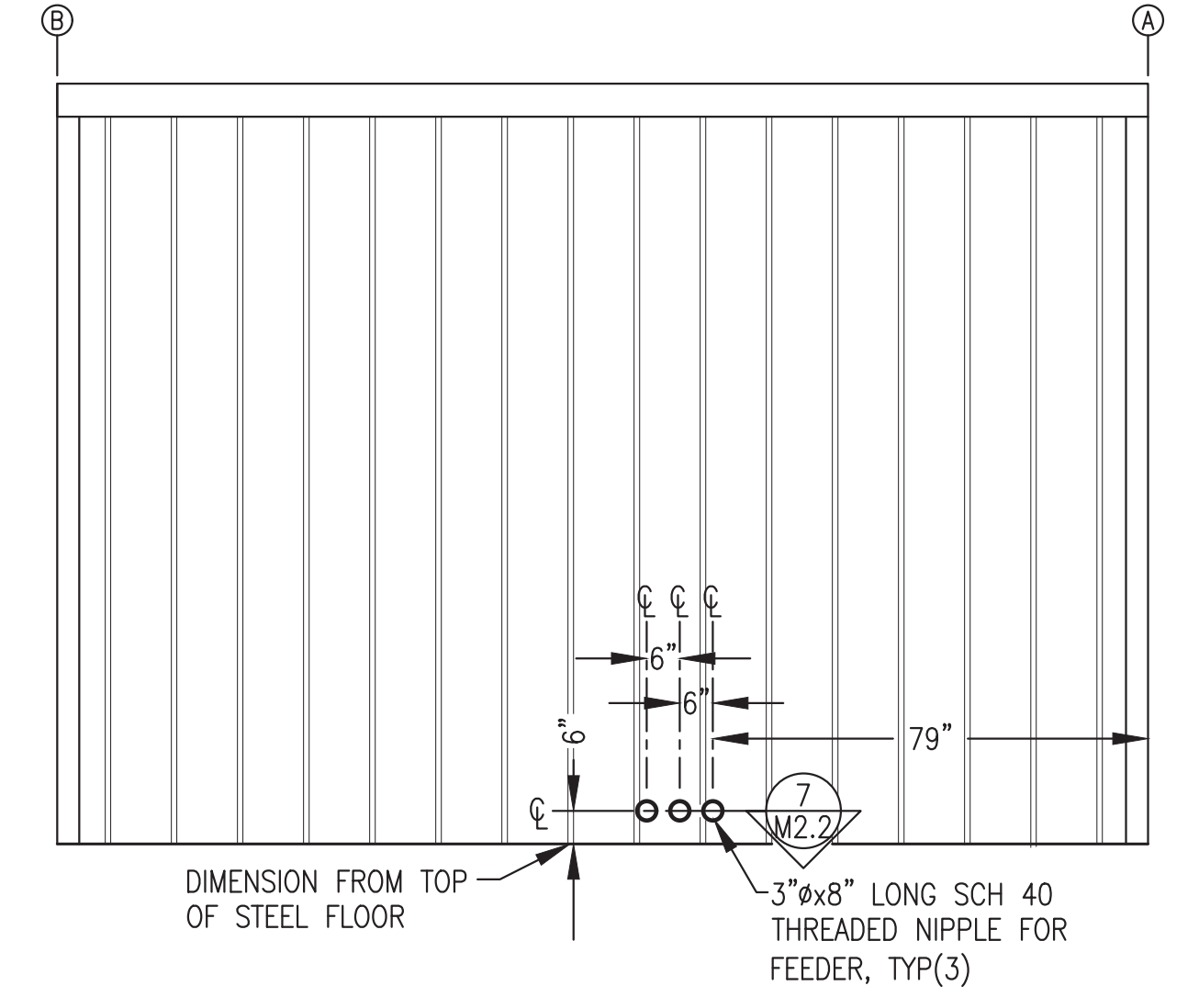

2 GRID 2 MECHANICAL WALL PENETRATION LAYOUT - EXTERIOR ELEVATION  
3/8"=1'-0"

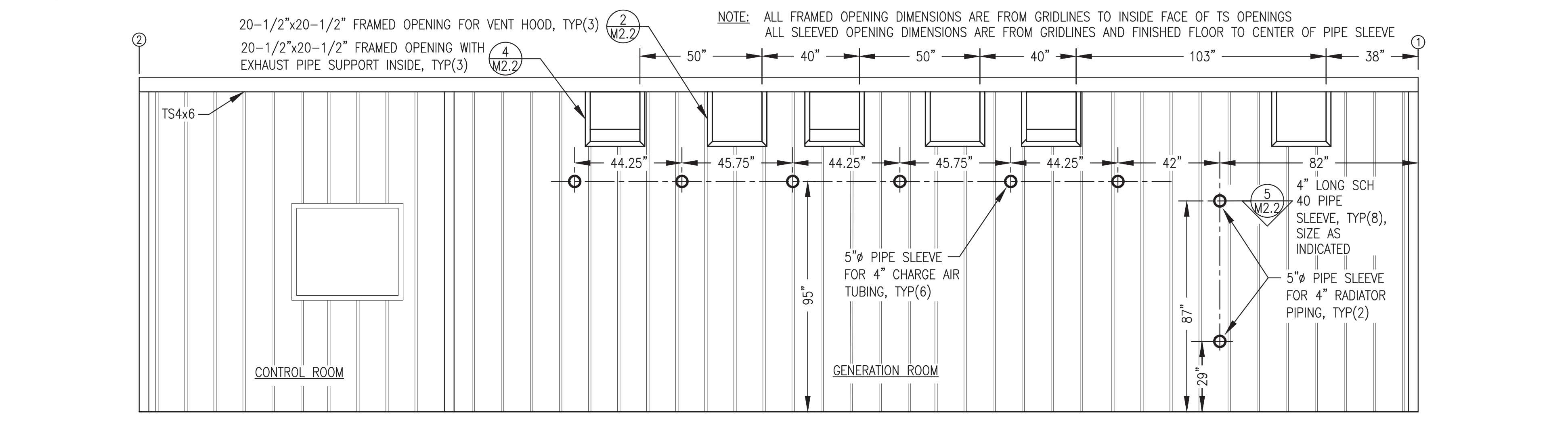

3 GRID A MECHANICAL WALL PENETRATION LAYOUT - EXTERIOR ELEVATION  
3/8"=1'-0"

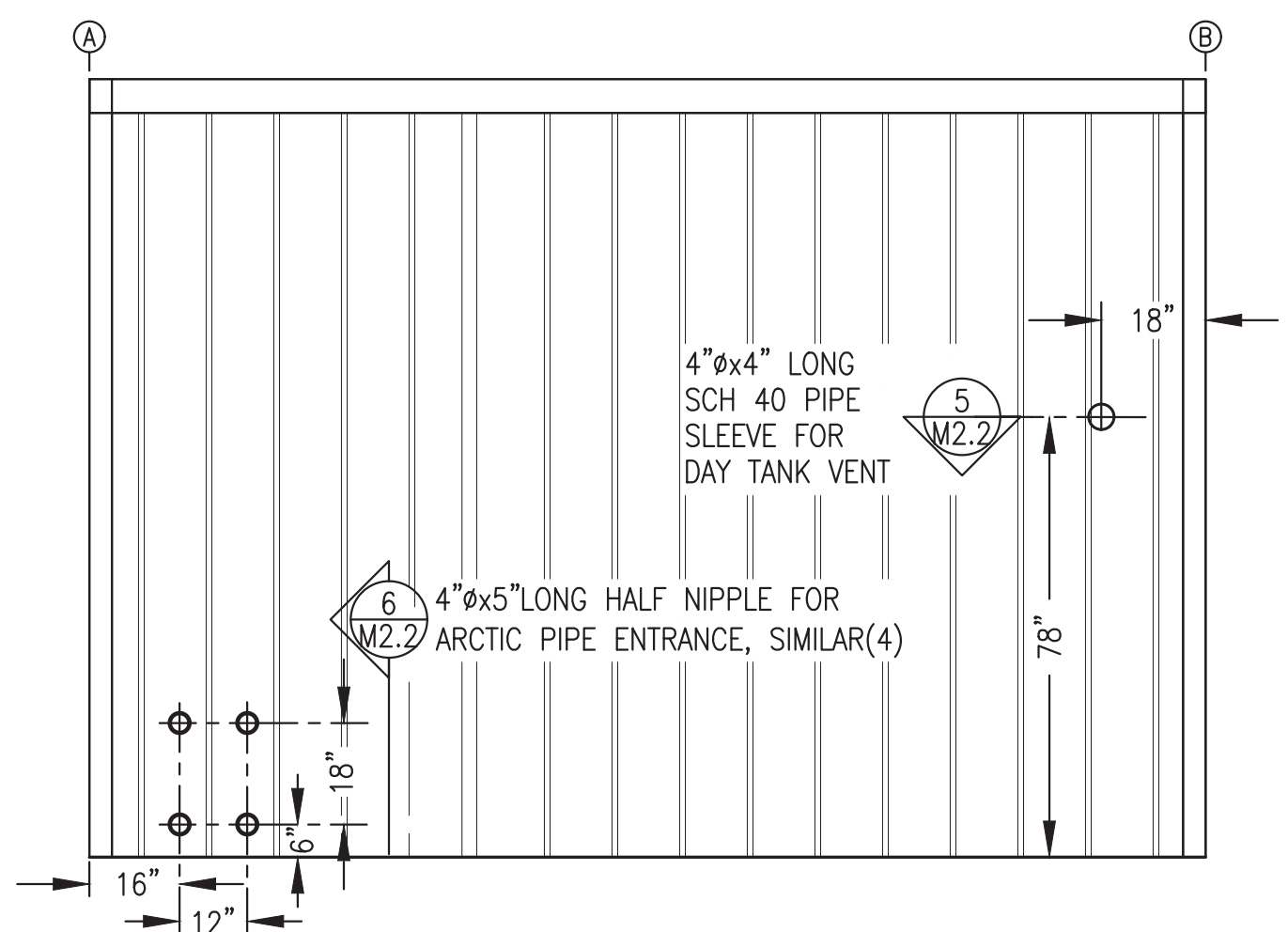

4 GRID 1 MECHANICAL WALL PENETRATION LAYOUT - EXTERIOR ELEVATION  
3/8"=1'-0"

ALL WORK ON THIS SHEET WAS PERFORMED AS PART OF THE PRIOR MODULE ASSEMBLY CONTRACT AND IS SHOWN HERE FOR REFERENCE ONLY.

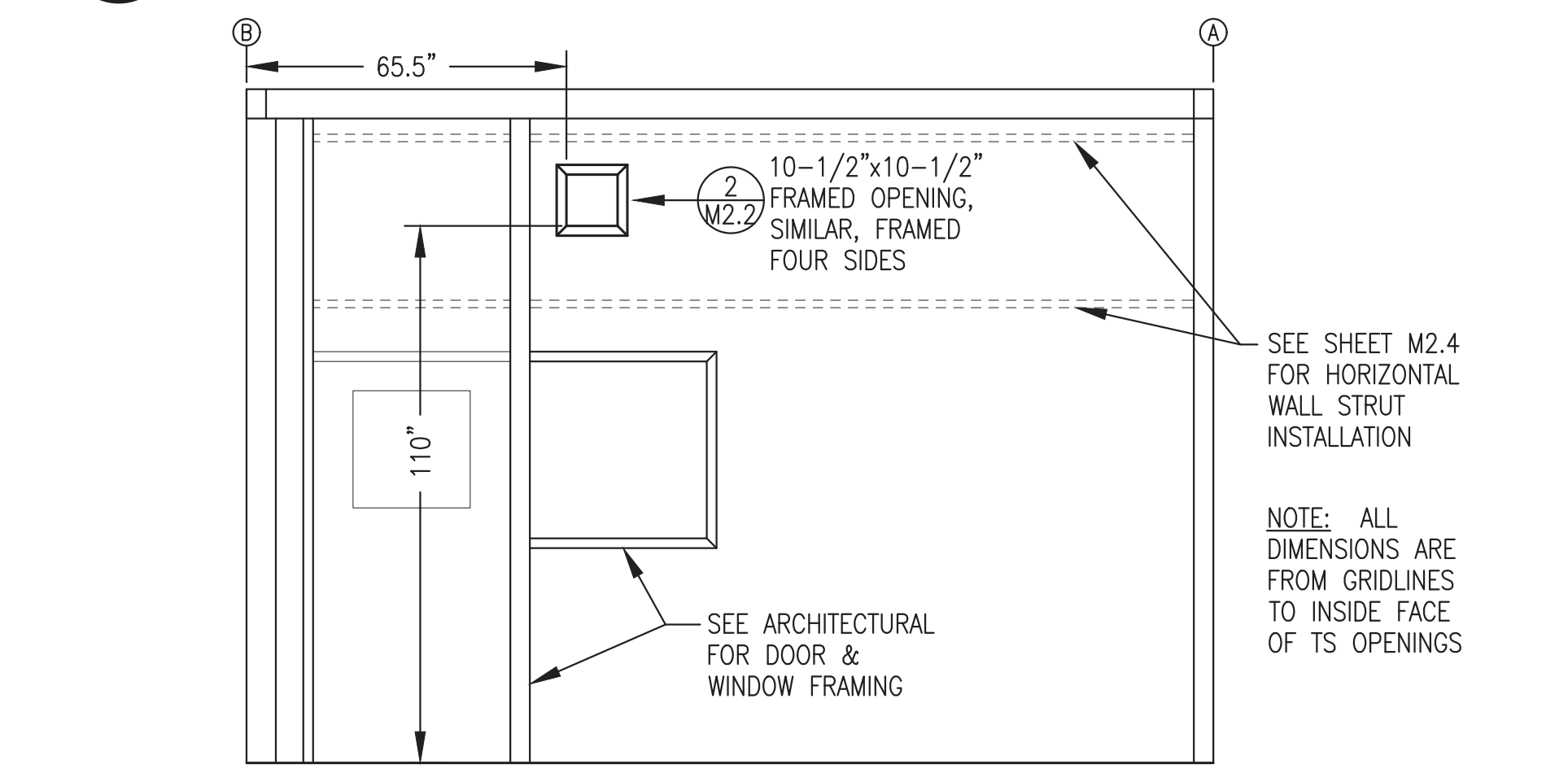

5 PARTITION MECHANICAL WALL PENETRATION LAYOUT - INTERIOR ELEVATION  
3/8"=1'-0"

REVISION #2  
ISSUED JULY  
2022



2	DETAIL 2 ADDED THIRD NIPPLE & CHANGED DIMENSIONS	7/6/22	BCG
1	REVISED FOR NEW ENGINE/GENERATOR SELECTION	6/9/22	BCG
REV.	DESCRIPTION	DATE	BY
PROJECT: NAPASKIAK POWER SYSTEM UPGRADE			
TITLE: MECHANICAL PENETRATIONS PLAN, ELEVATIONS & DETAILS			
DRAWN BY: JTD		SCALE: AS NOTED	
DESIGNED BY: BCG		DATE: 4/18/22	
FILE NAME: RAM_PP_M2-M7		SHEET: M2.1	
PROJECT NUMBER: P.O. 111405, Anchorage, AK 99511 (907)349-0100			

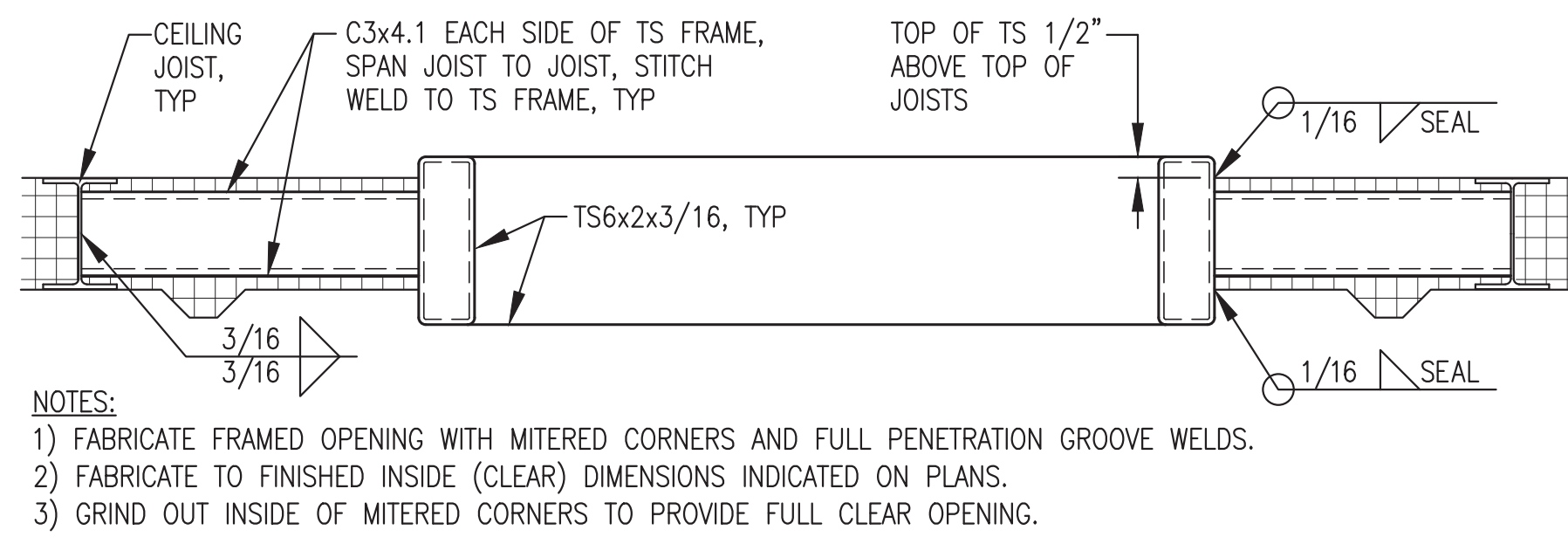

1 TYPICAL ROOF OPENING DETAIL  
M2.2 2'-1'-0"

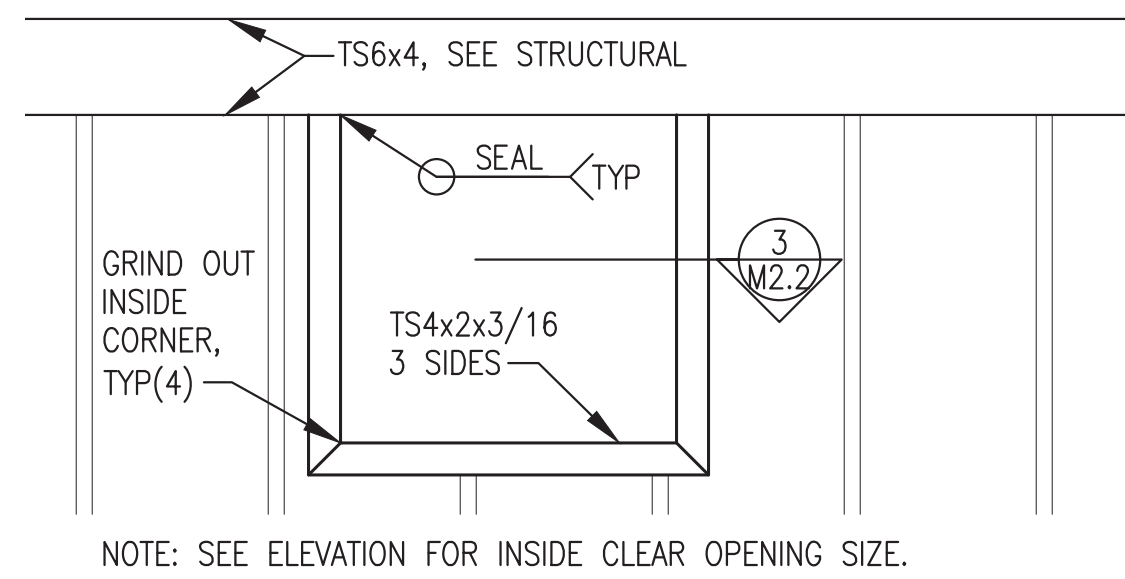

2 TYPICAL WALL OPENING - ELEVATION  
M2.2 1'-1'-0"

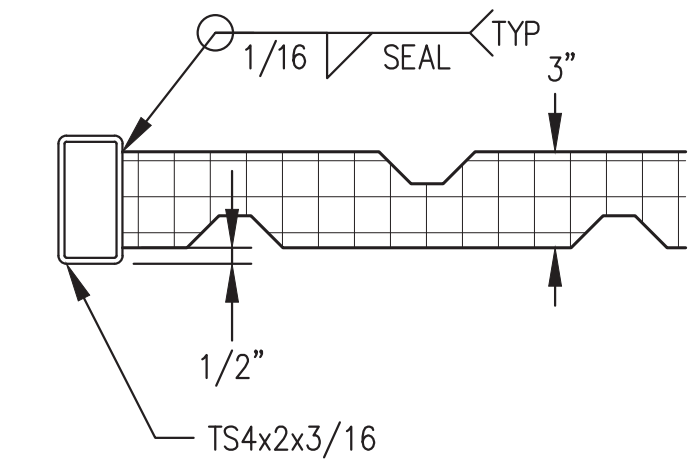

3 TYPICAL SECTION THROUGH WALL OPENING  
M2.2 2'-1'-0"

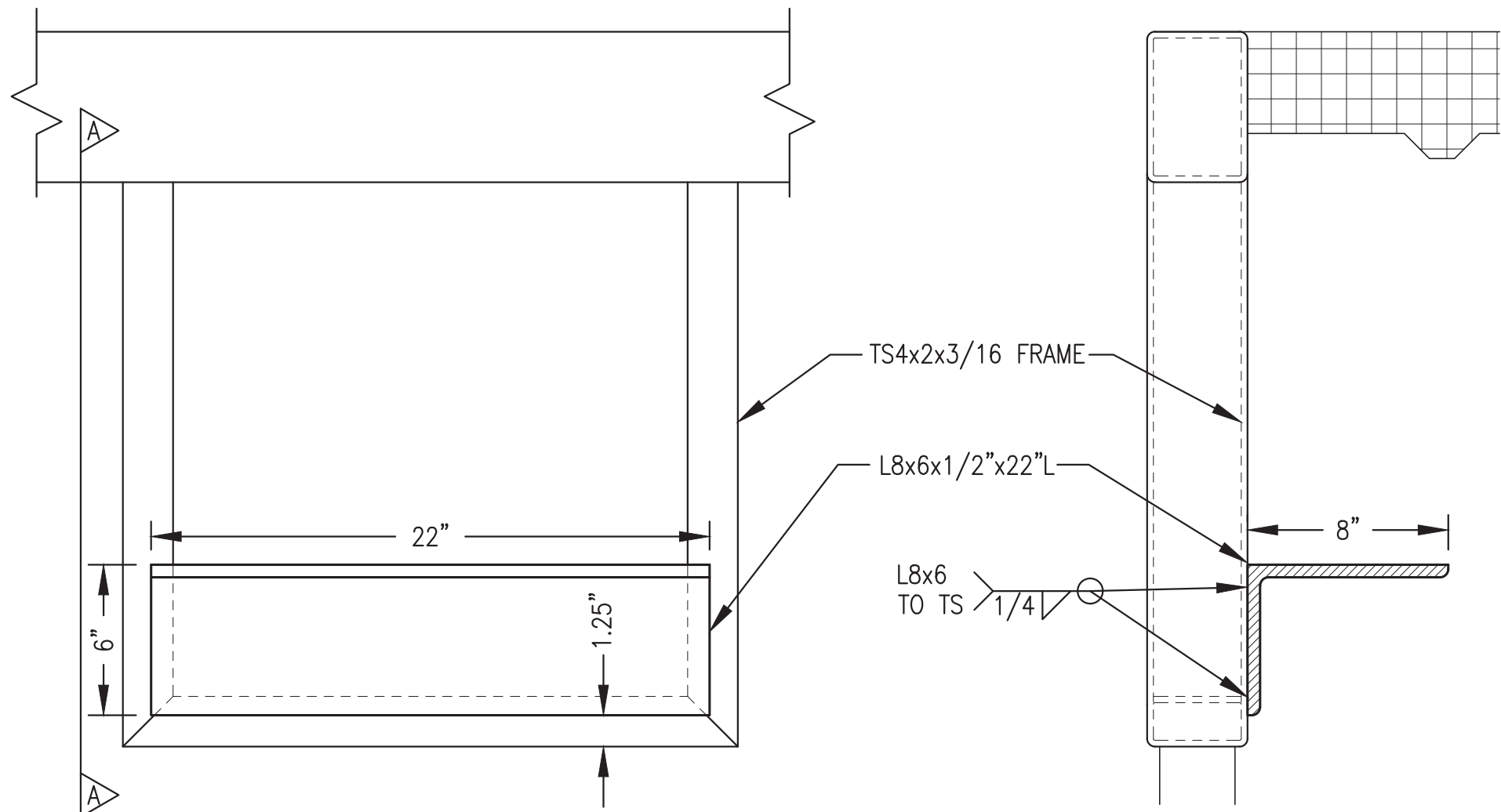

4 EXHAUST PIPE SUPPORT AT FRAMED OPENING  
M2.2 2'-1'-0"

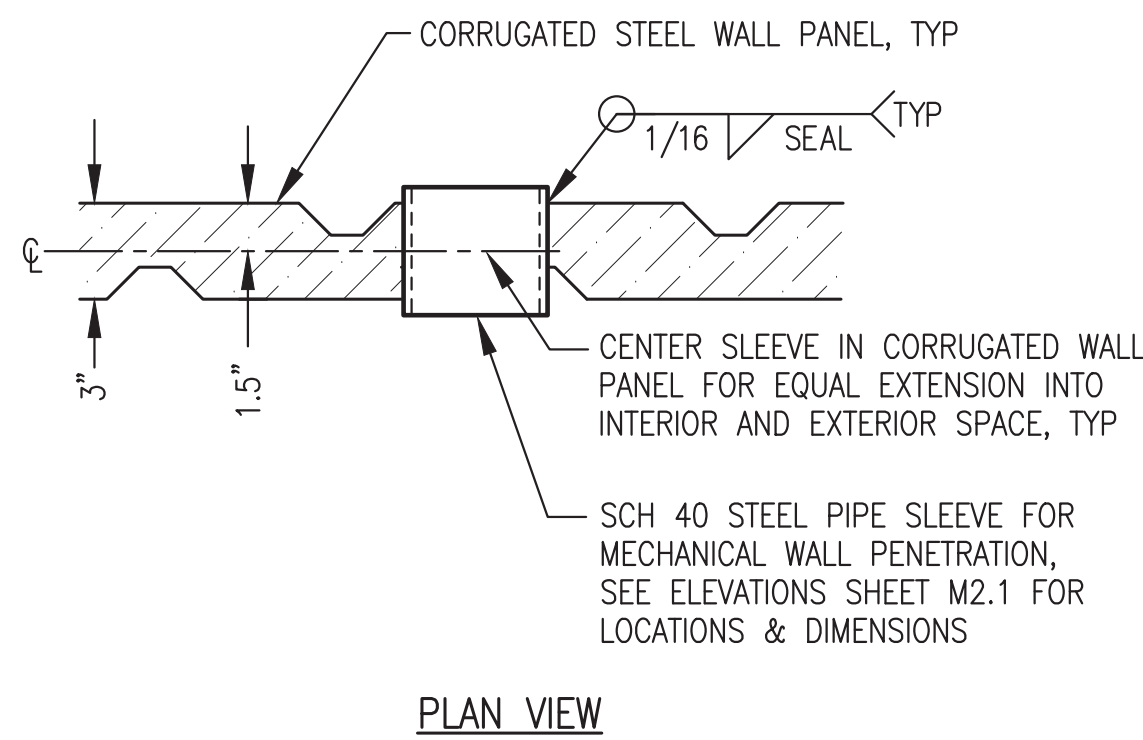

5 TYPICAL WALL PENETRATION PIPE SLEEVE  
M2.2 2'-1'-0"

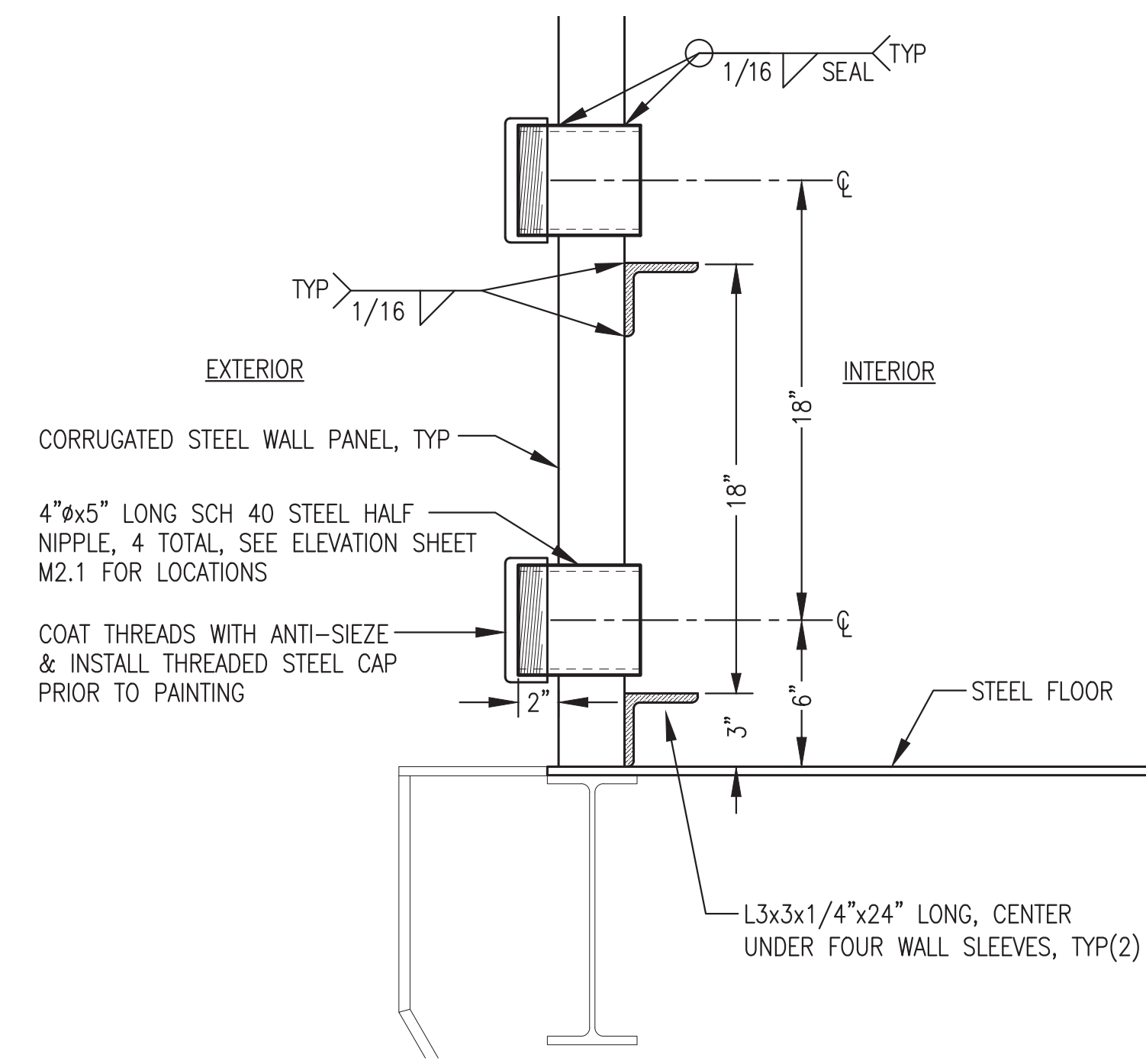

6 TYPICAL HEAT RECOVERY ARCTIC PIPE WALL PENETRATION  
M2.2 2'-1'-0"

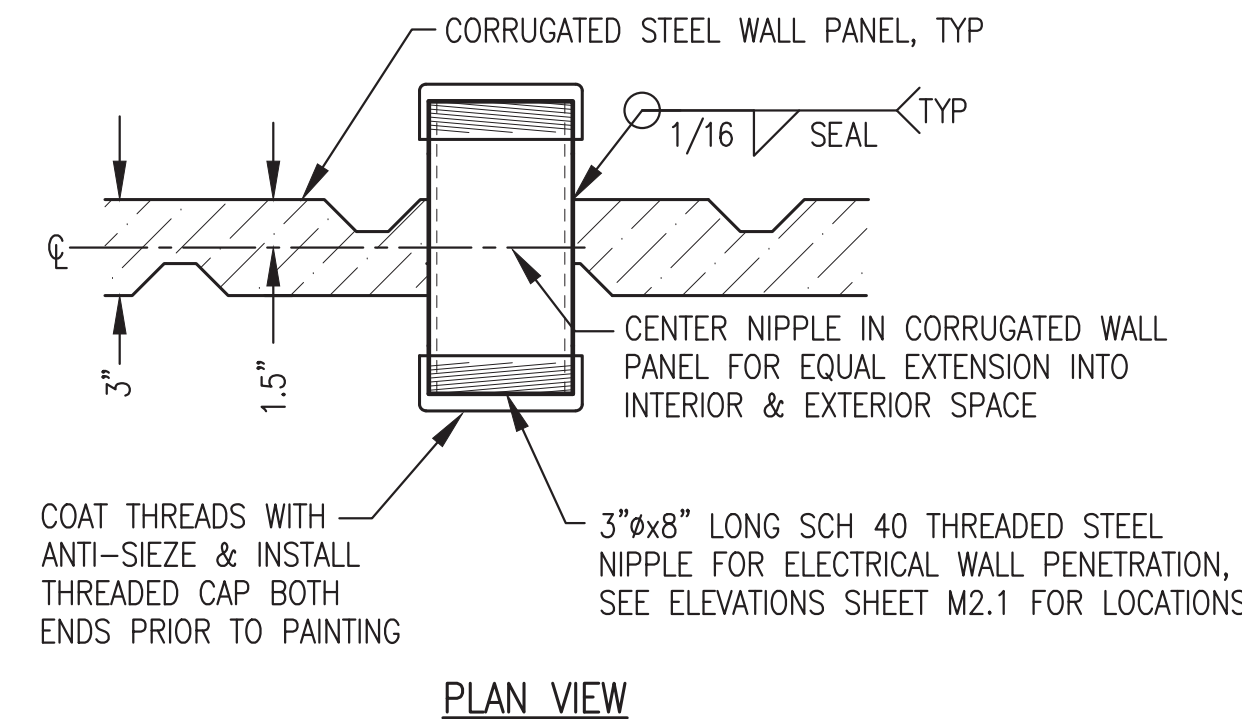

7 TYPICAL ELECTRIC POWER FEEDER CONDUCTOR WALL PENETRATION  
M2.2 2'-1'-0"

ALL WORK ON THIS SHEET WAS PERFORMED AS PART OF THE PRIOR MODULE ASSEMBLY CONTRACT AND IS SHOWN HERE FOR REFERENCE ONLY.

REVISION #1  
ISSUED JUNE  
2022



REV.	DESCRIPTION	DATE	BY
1	REVISED FOR NEW ENGINE/GENERATOR SELECTION	6/9/22	BCG

PROJECT: NAPASKIAK POWER SYSTEM UPGRADE

TITLE: MECHANICAL PENETRATION DETAILS

DRAWN BY: JTD  
DESIGNED BY: BCG  
FILE NAME: RAM PP M2-M7  
PROJECT NUMBER:

SCALE: AS NOTED  
DATE: 4/18/22  
SHEET: M2.2

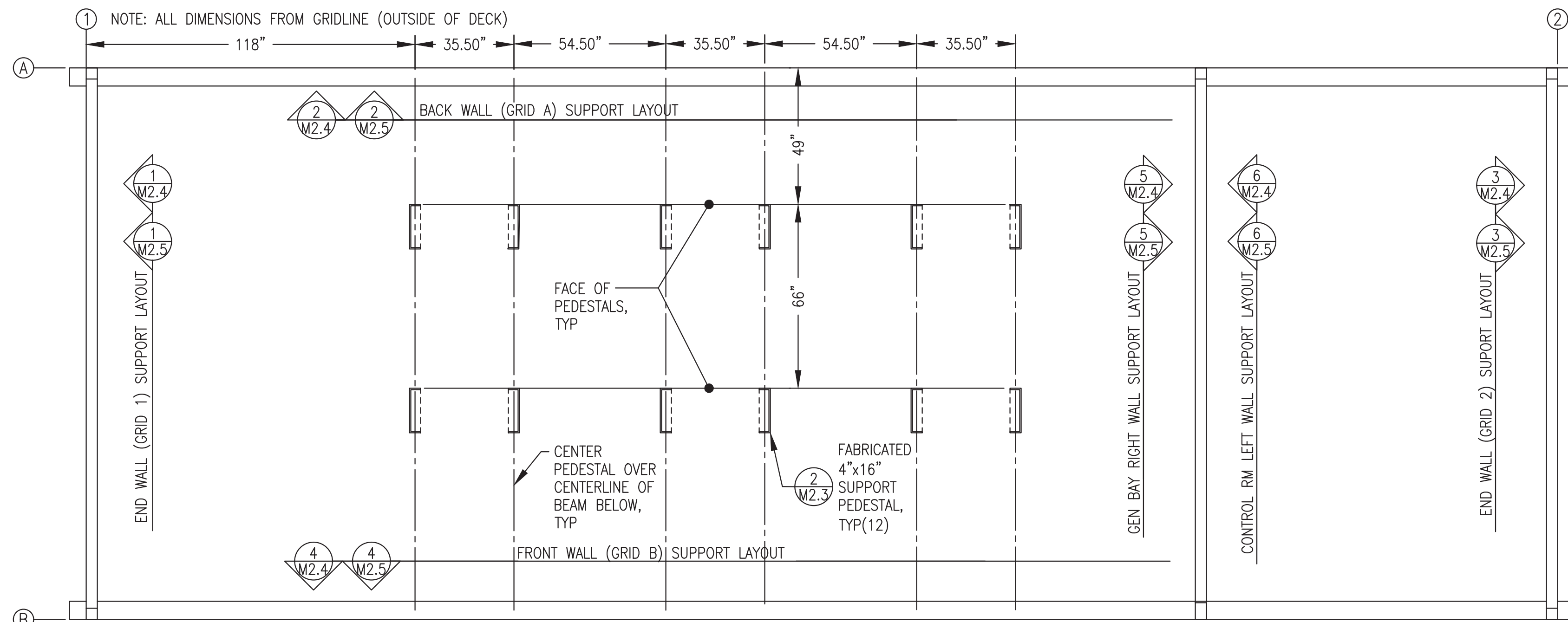

**1** MODULE MECHANICAL SUPPORT PLAN  
**M2.3** 3/8"=1'-0"

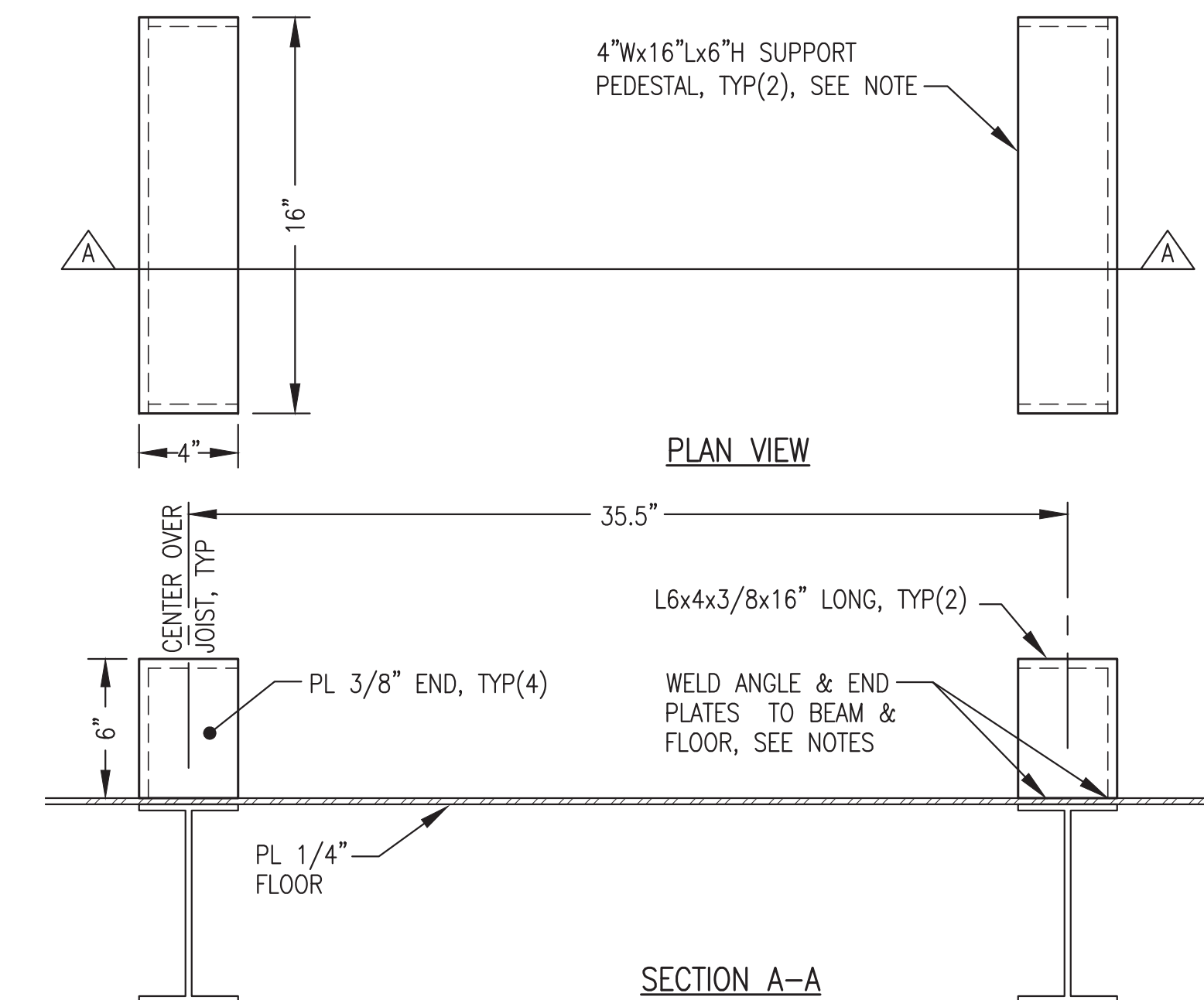

NOTES: 1) MAKE ALL JOINTS WITH CONTINUOUS GROOVE OR FILLET WELDS.  
 2) SLOT FLOOR PLATE 3 SIDES, WELD PEDESTAL TO TOP OF BEAM, THEN SEAL WELD TO FLOOR PLATE ALL AROUND INSIDE & OUT.

- GENERAL NOTES:**
- 1) FABRICATE PEDESTALS FROM ASTM A36 ANGLE AND PLATES AS SHOWN.
  - 2) ALL STRUT 12 GAUGE 1-5/8"x1-5/8" SOLID BACK PLAIN (UNFINISHED). B-LINE B22-PLN OR EQUAL. PURCHASE IN 20' LENGTHS TO MINIMIZE SPLICES.
  - 3) INSTALL ALL SUPPORTS INDICATED AND GRIND SMOOTH PRIOR TO SANDBLASTING MODULE. SANDBLAST AND PAINT ALL SUPPORTS THIS SHEET EQUIVALENT TO MODULE INTERIOR. SEE SHEET A1 FOR PAINTING SPECIFICATIONS.

**2** SUPPORT PEDESTAL FABRICATION  
**M2.3** 2"=1'-0"

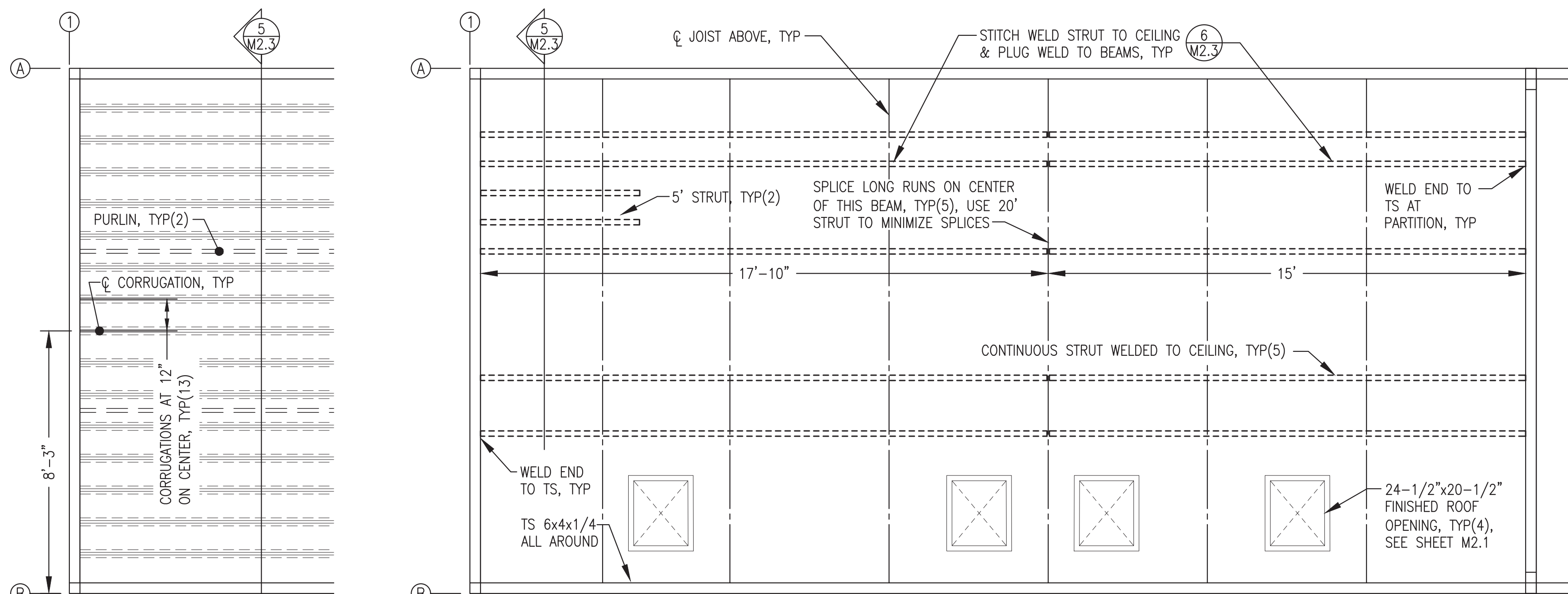

**3** CEILING PLATE CONFIGURATION LAYOUT  
**M2.3** 3/8"=1'-0"

**4** CEILING STRUT SUPPORT LAYOUT PLAN  
**M2.3** 3/8"=1'-0"

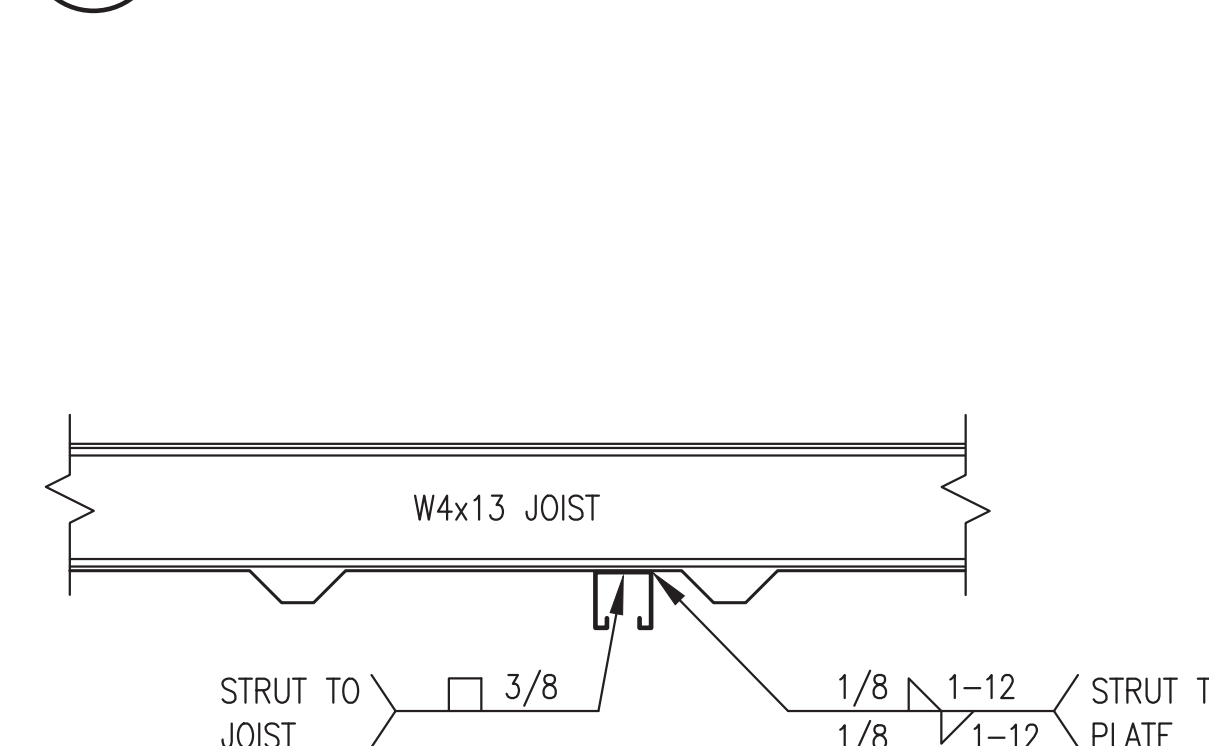

**6** STRUT ATTACHMENT TO CEILING  
**M2.3** NO SCALE

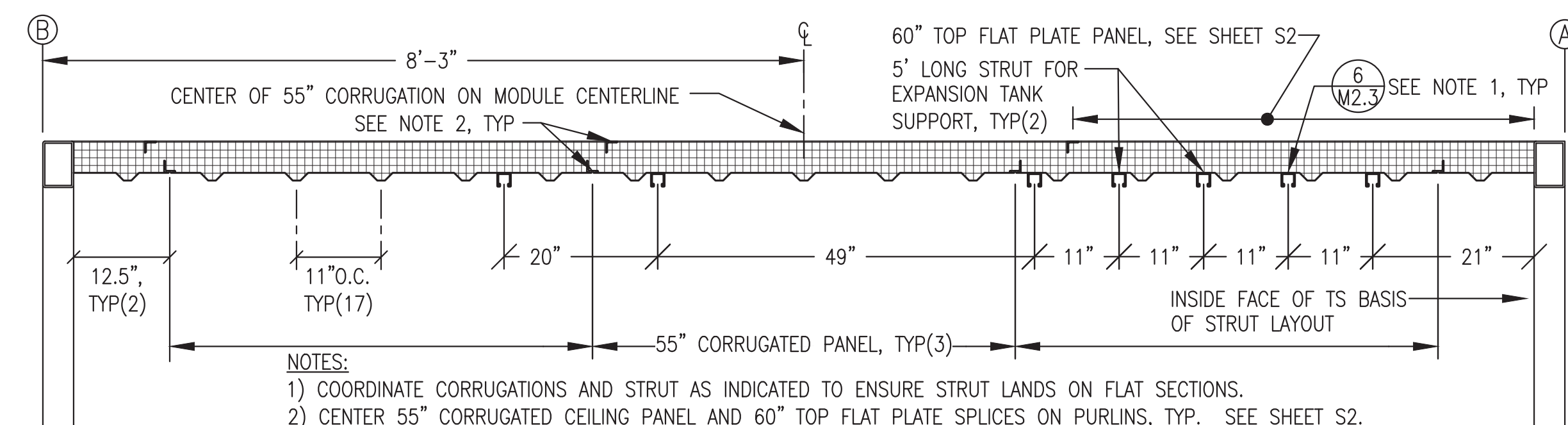

**5** SECTION THROUGH CEILING - CORRUGATION & STRUT LAYOUT  
**M2.3** 3/4"=1'-0"

ALL WORK ON THIS SHEET WAS PERFORMED AS PART OF THE PRIOR MODULE ASSEMBLY CONTRACT AND IS SHOWN HERE FOR REFERENCE ONLY.

REVISION #1  
 ISSUED JUNE  
 2022



1	REVISED FOR NEW ENGINE/GENERATOR SELECTION	6/9/22	BCG
REV.	DESCRIPTION	DATE	BY
 ALASKA ENERGY AUTHORITY			
PROJECT: NAPASKIAK POWER SYSTEM UPGRADE			
TITLE: MECHANICAL SUPPORT PLANS & DETAILS			
DRAWN BY: JTD		SCALE: AS NOTED	
DESIGNED BY: BCG		DATE: 4/18/22	
FILE NAME: RAM PP M2-M7		SHEET:	
PROJECT NUMBER:		<b>M2.3</b>	
P.O. 111405, Anchorage, AK 99511 (907)349-0100			

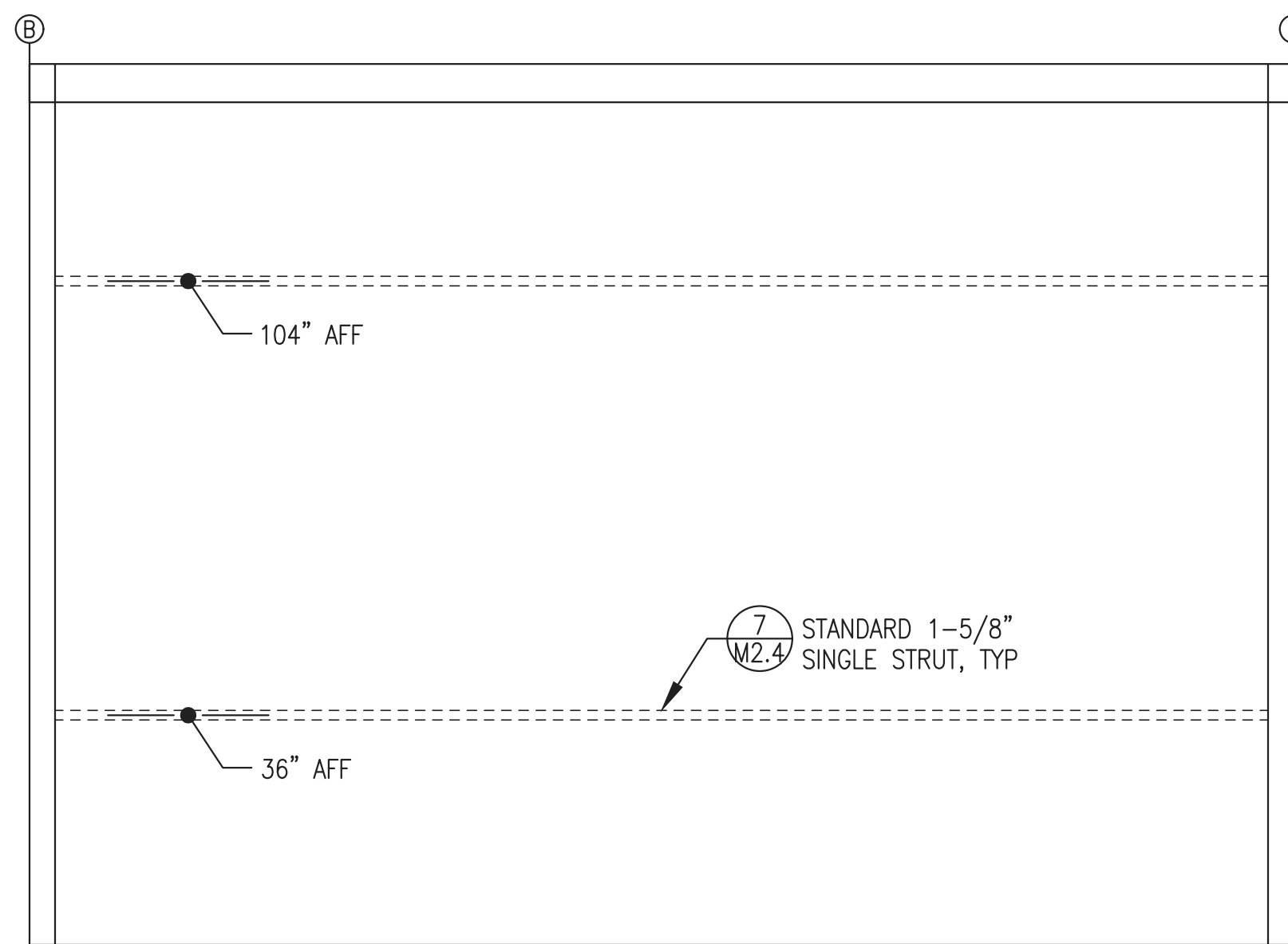

**1** END WALL (GRID 1) HORIZONTAL WALL STRUT LAYOUT  
 M2.4 1/2"=1'-0"

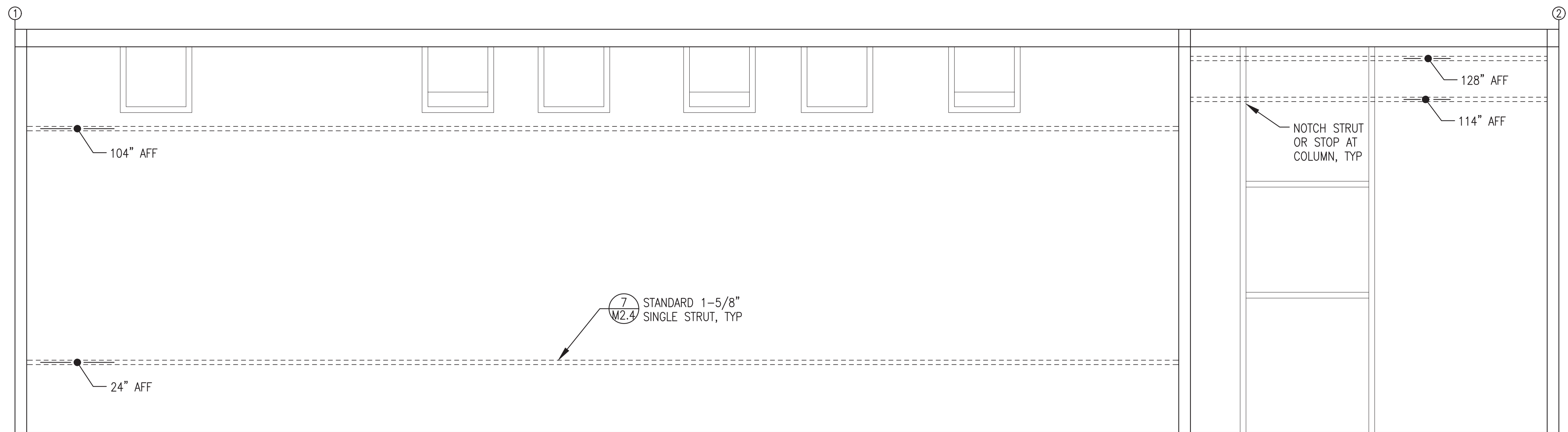

**2** BACK WALL (GRID A) HORIZONTAL WALL STRUT LAYOUT  
 M2.4 1/2"=1'-0"

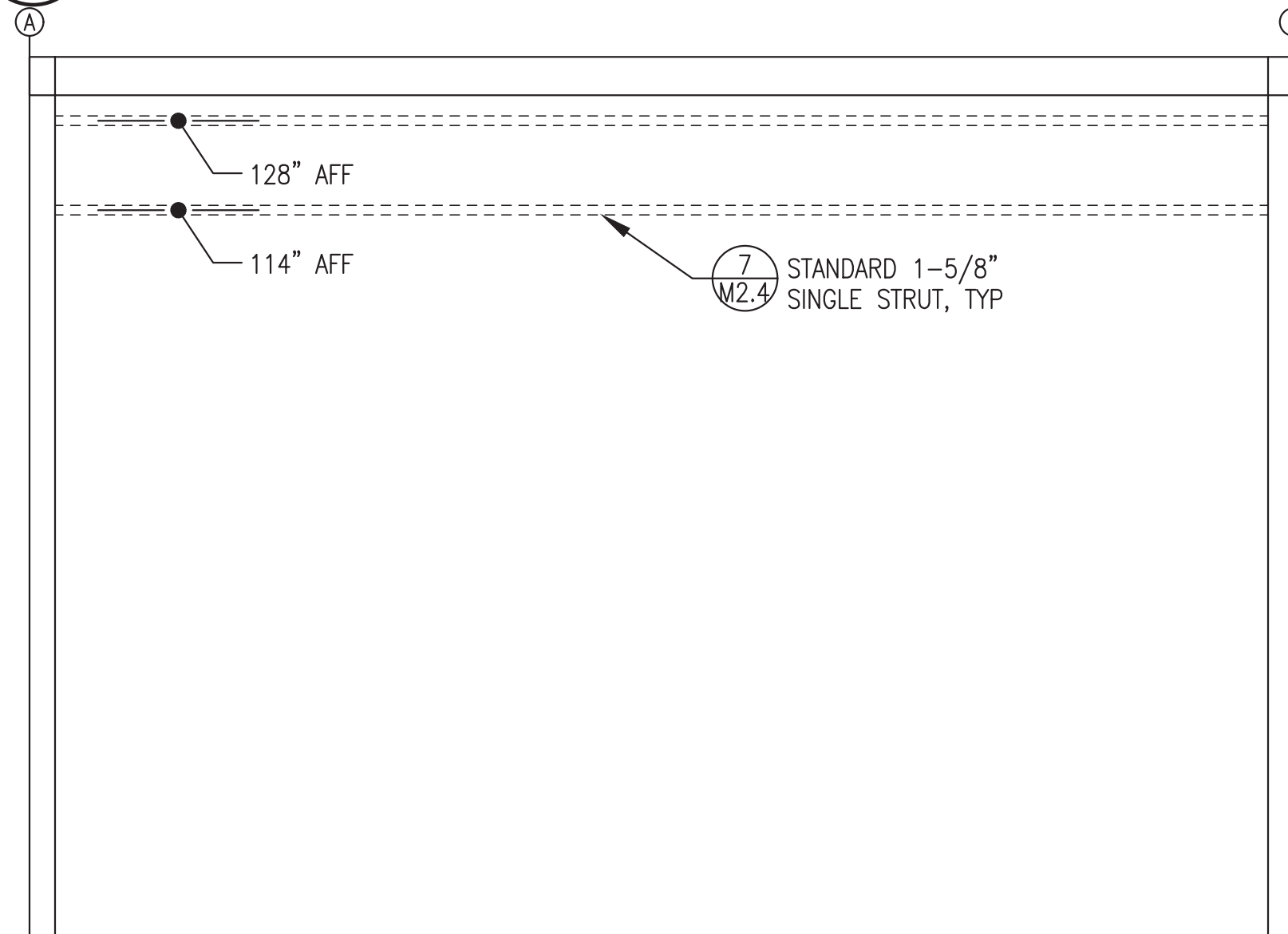

**3** END WALL (GRID 2) HORIZONTAL WALL STRUT LAYOUT  
 M2.4 1/2"=1'-0"

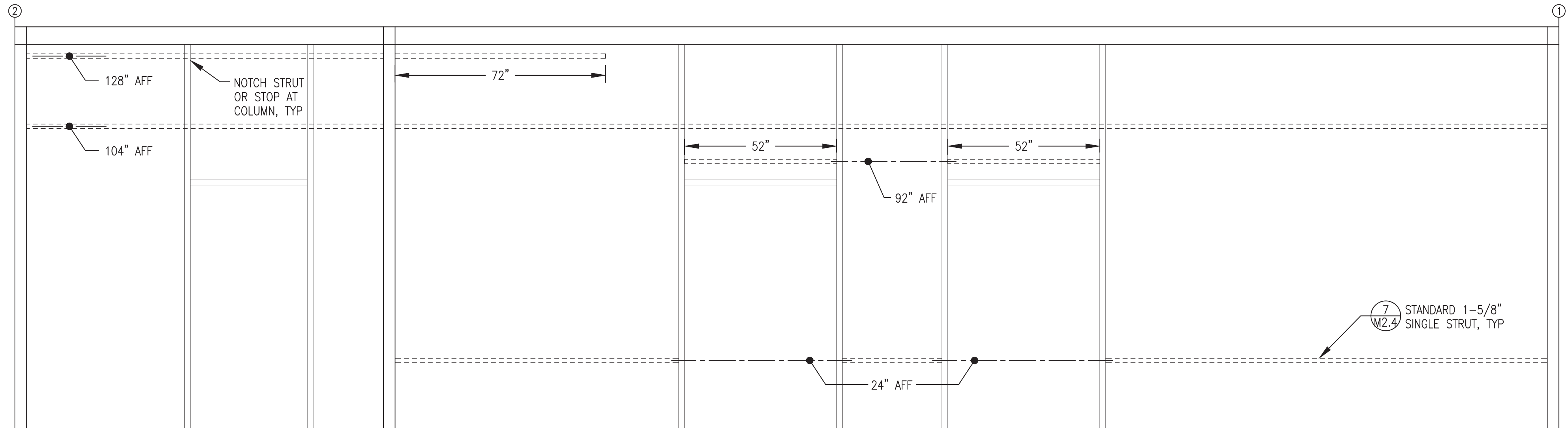

**4** FRONT WALL (GRID B) HORIZONTAL WALL STRUT LAYOUT  
 M2.4 1/2"=1'-0"

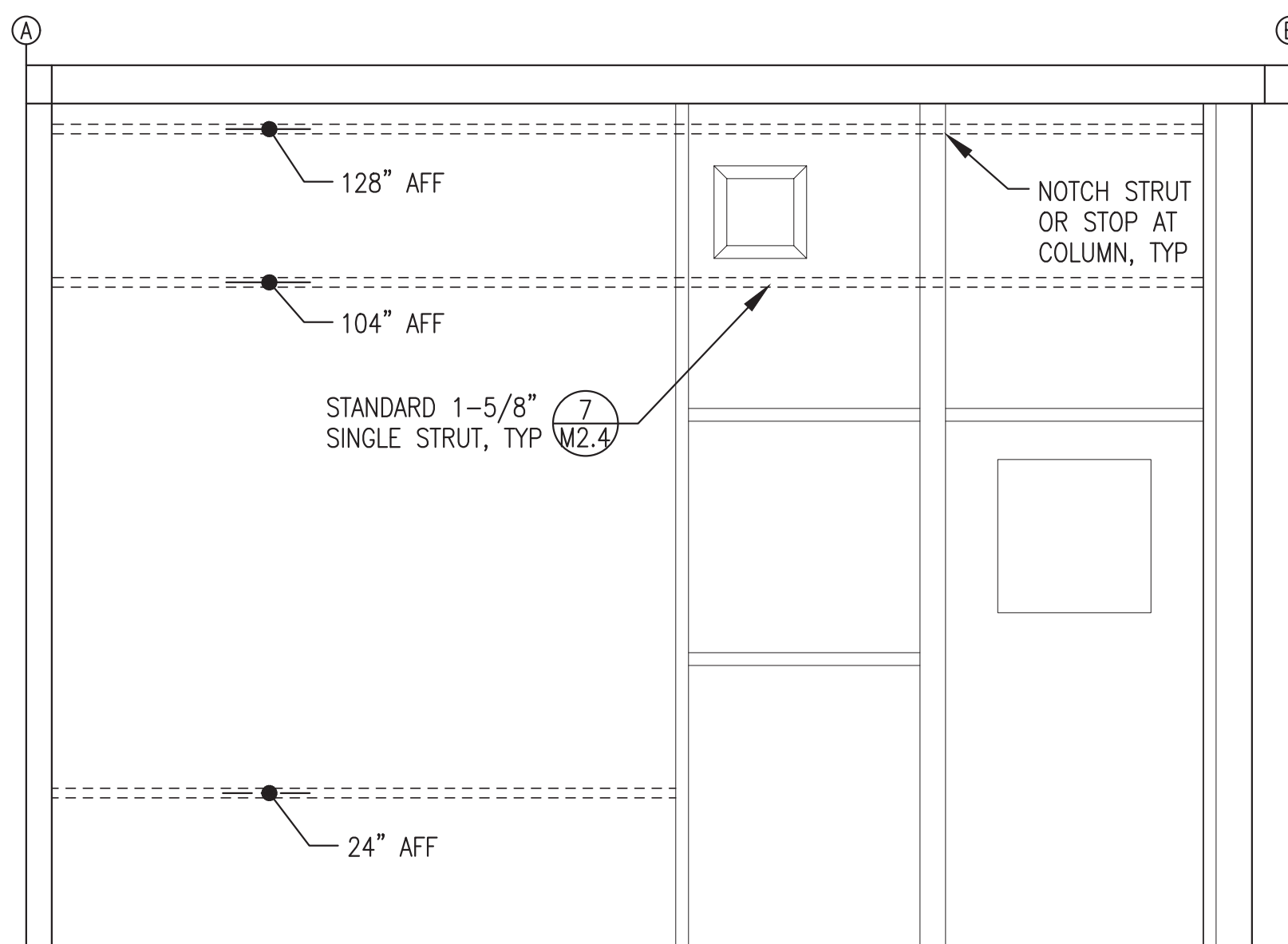

**5** GEN BAY RIGHT WALL HORIZONTAL WALL STRUT LAYOUT  
 M2.4 1/2"=1'-0"

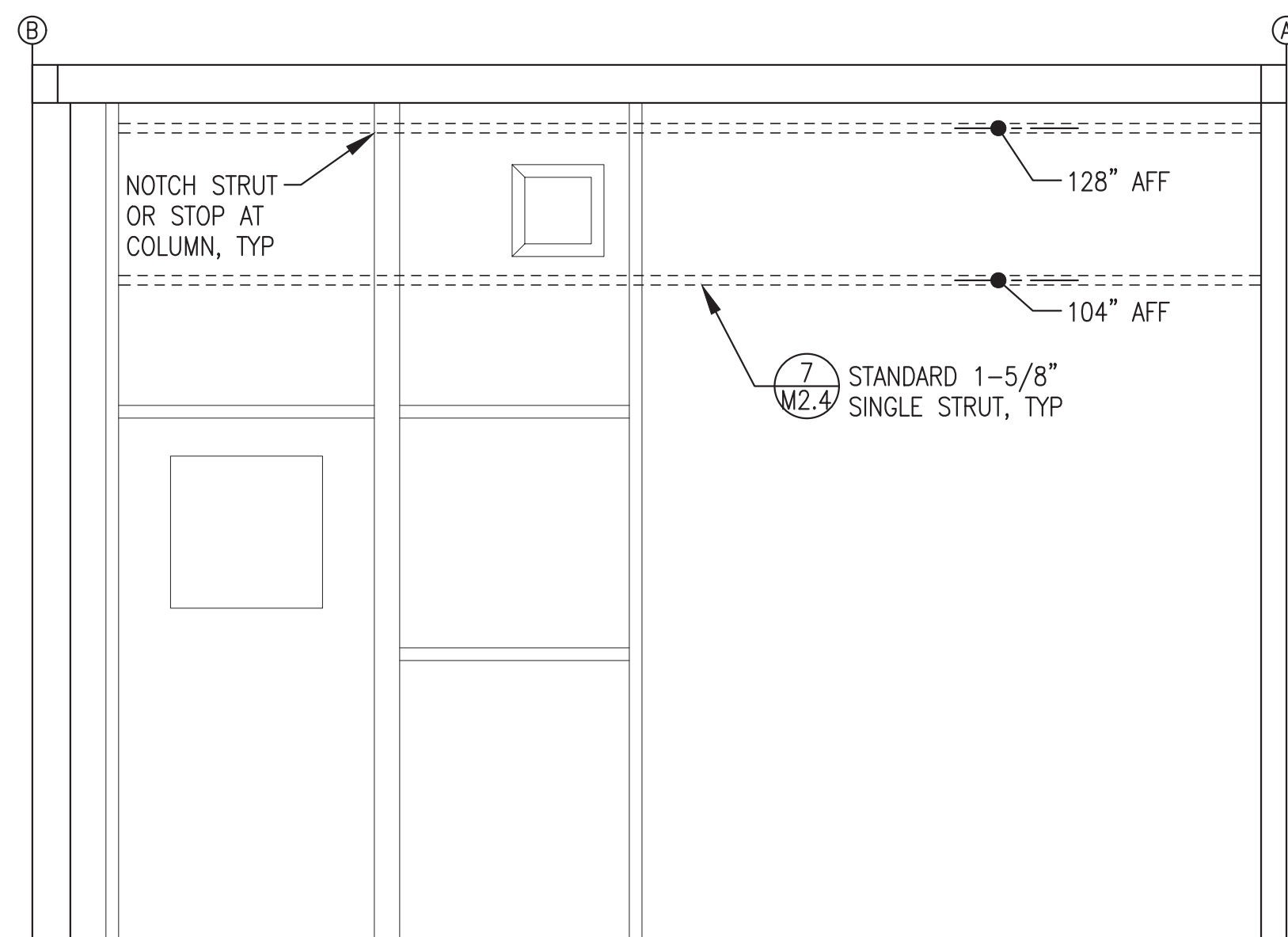

**6** CONTROL ROOM LEFT WALL HORIZONTAL WALL STRUT LAYOUT  
 M2.4 1/2"=1'-0"

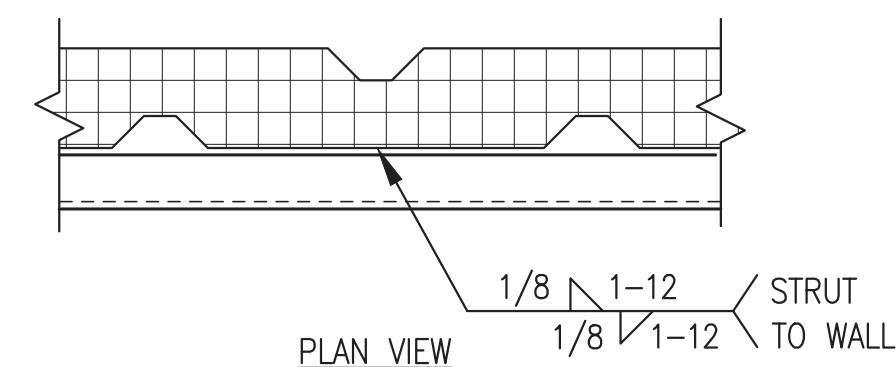

**7** HORIZONTAL WALL STRUT ATTACHMENT  
 M2.4 NO SCALE

**HORIZONTAL WALL STRUT NOTES:**

- 1) ALL LOCATIONS ARE CENTERLINE OF STRUT ABOVE FINISHED FLOOR (AFF).
- 2) ALL STRUT SHALL BE 12 GAUGE, 1-5/8" x 1-5/8", PLAIN (UN-FINISHED BLACK) WITH SOLID BACK, B-LINE B22-PLN OR EQUAL.
- 3) PRIOR TO PAINTING MODULE, WELD ALL HORIZONTAL STRUT SECTIONS TO WALLS AS SHOWN. SANDBLAST AND PAINT STRUT WITH MODULE INTERIOR WALLS. SEE SHEET A1 FOR PAINTING SPECIFICATIONS.

REVISION #1  
 ISSUED JUNE  
 2022



ALL WORK ON THIS SHEET WAS PERFORMED AS PART OF THE PRIOR MODULE ASSEMBLY CONTRACT AND IS SHOWN HERE FOR REFERENCE ONLY.

REV.	DESCRIPTION	DATE	BY
1	REVISED FOR NEW ENGINE/GENERATOR SELECTION	6/9/22	BCG

ALASKA ENERGY AUTHORITY	
PROJECT: NAPASKIAK POWER SYSTEM UPGRADE	
TITLE: MECHANICAL SUPPORT HORIZONTAL WALL STRUT INSTALLATION	
DRAWN BY: JTD	SCALE: AS NOTED
DESIGNED BY: BCG	DATE: 4/18/22
FILE NAME: RAM_PP_M2-M7	SHEET: M2.4
PROJECT NUMBER: P.O. 111405, Anchorage, AK 99511 (907)349-0100	

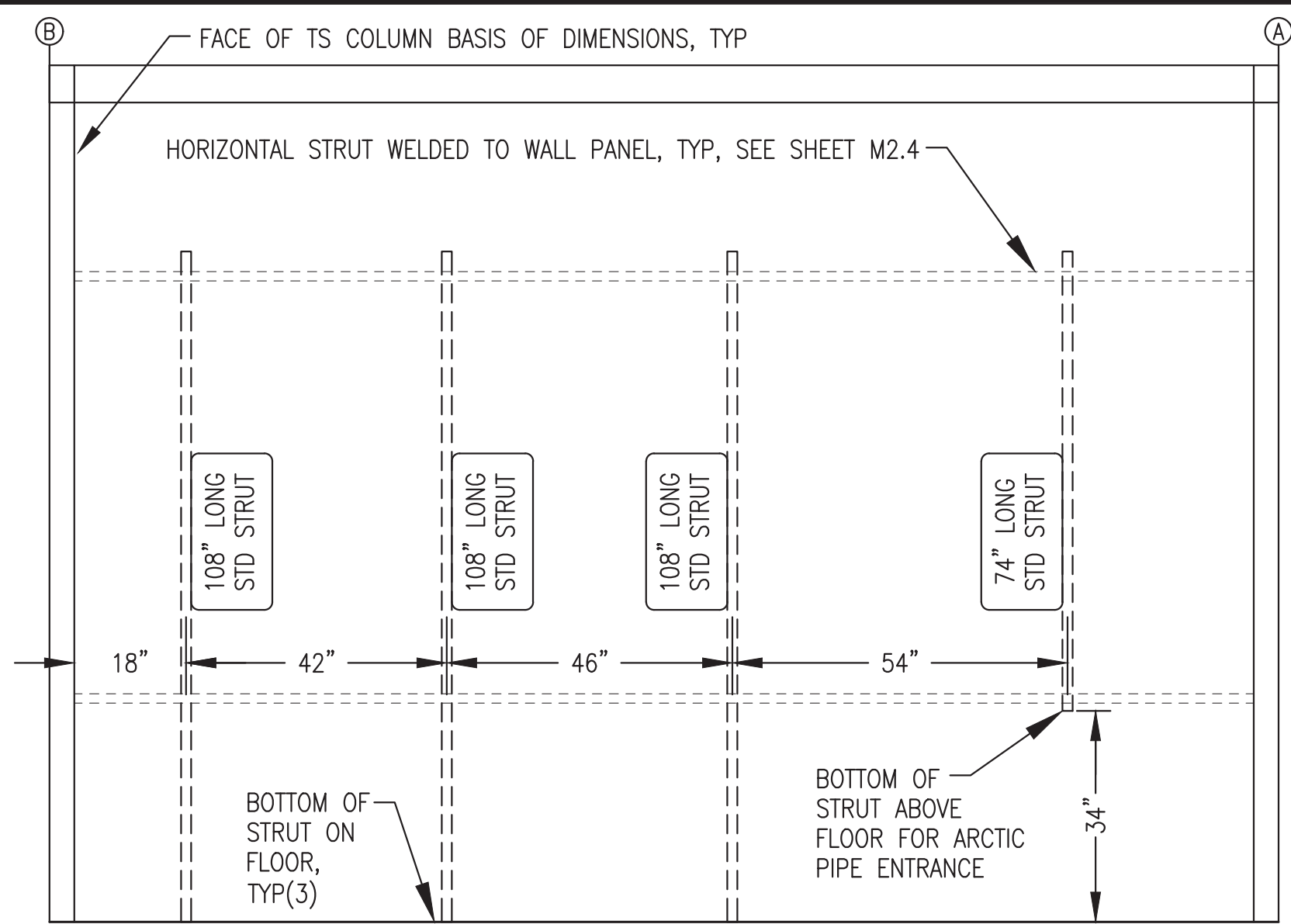

**1** END WALL (GRID 1) VERTICAL WALL STRUT LAYOUT  
**M2.5** 1/2"=1'-0"

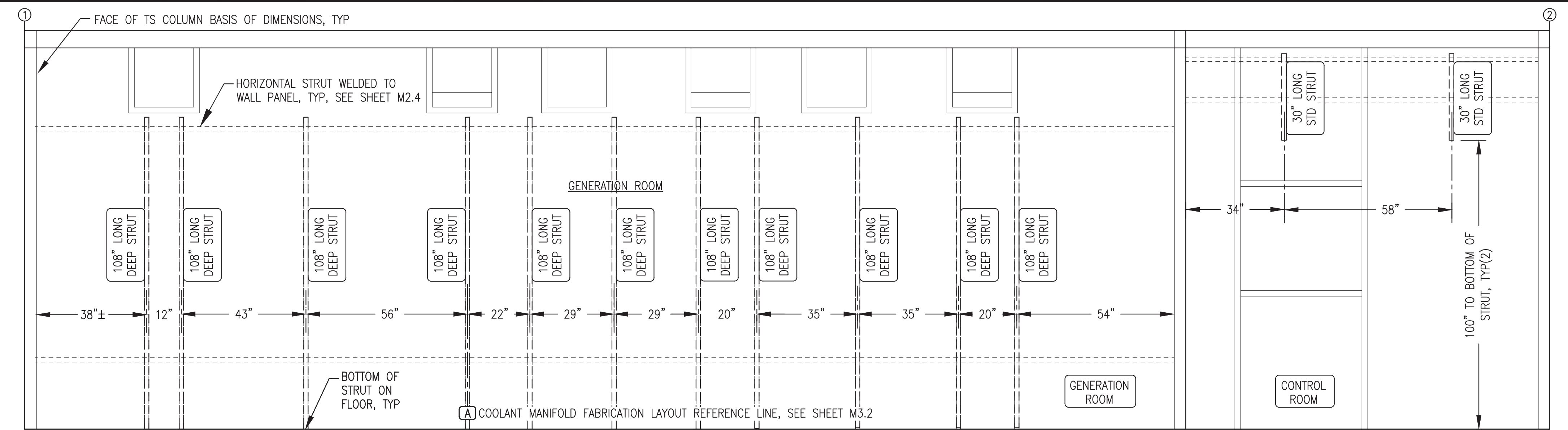

**2** BACK WALL (GRID A) VERTICAL WALL STRUT LAYOUT  
**M2.5** 1/2"=1'-0"

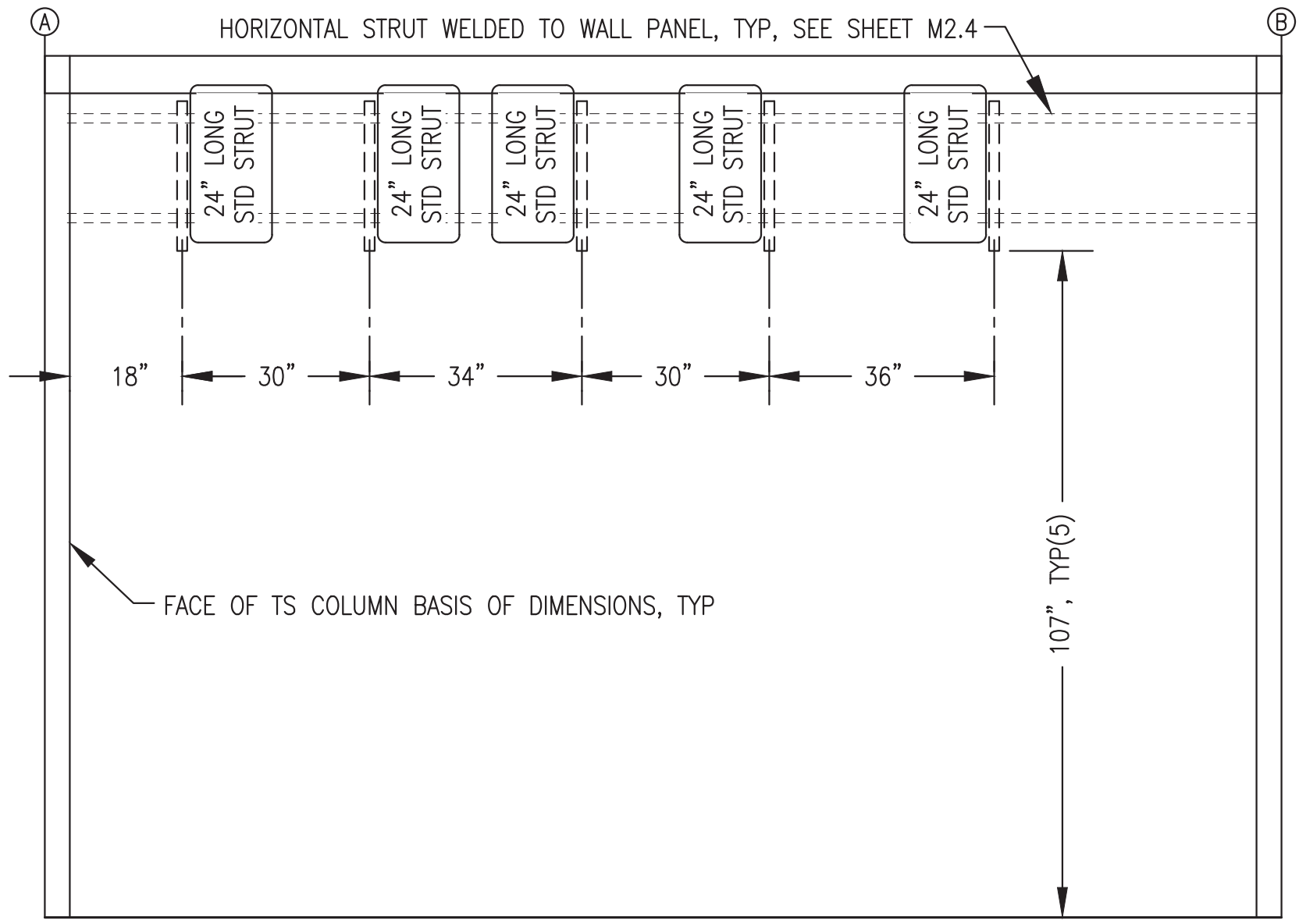

**3** END WALL (GRID 2) VERTICAL WALL STRUT LAYOUT  
**M2.5** 1/2"=1'-0"

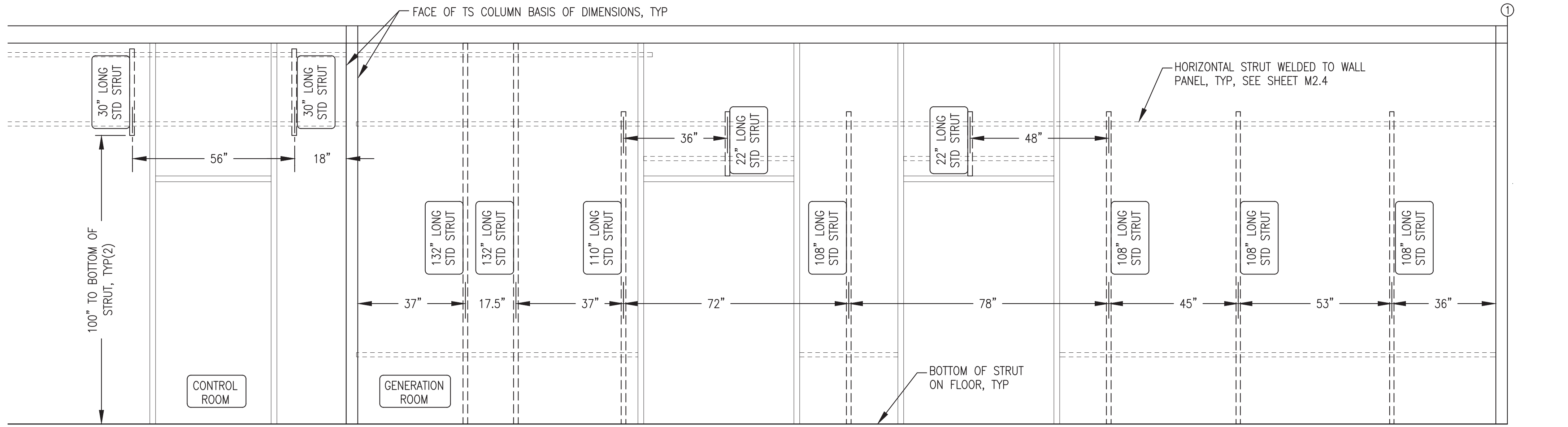

**4** FRONT WALL (GRID B) VERTICAL WALL STRUT LAYOUT  
**M2.5** 1/2"=1'-0"

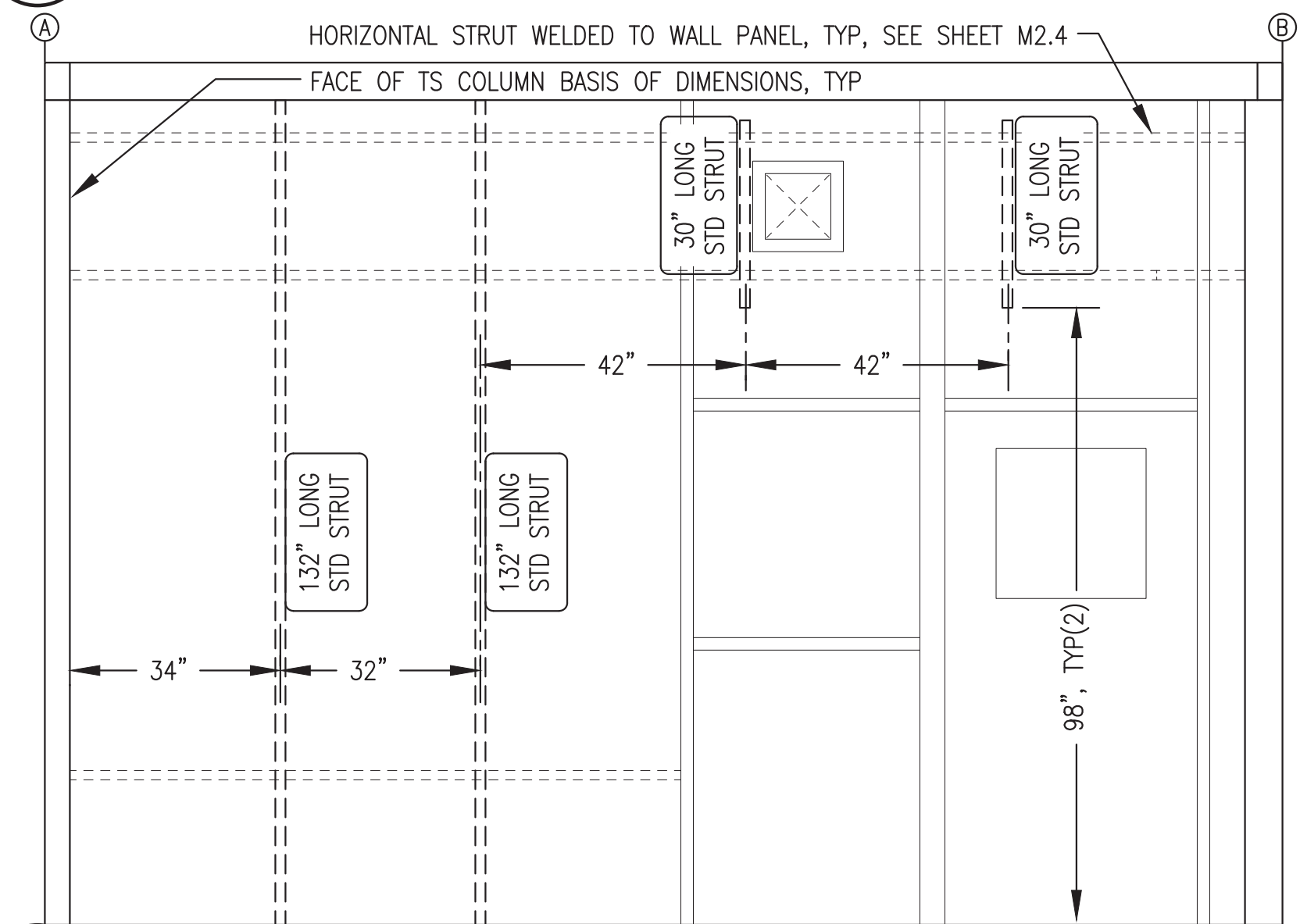

**5** GEN ROOM INTERIOR WALL VERTICAL WALL STRUT LAYOUT  
**M2.5** 1/2"=1'-0"

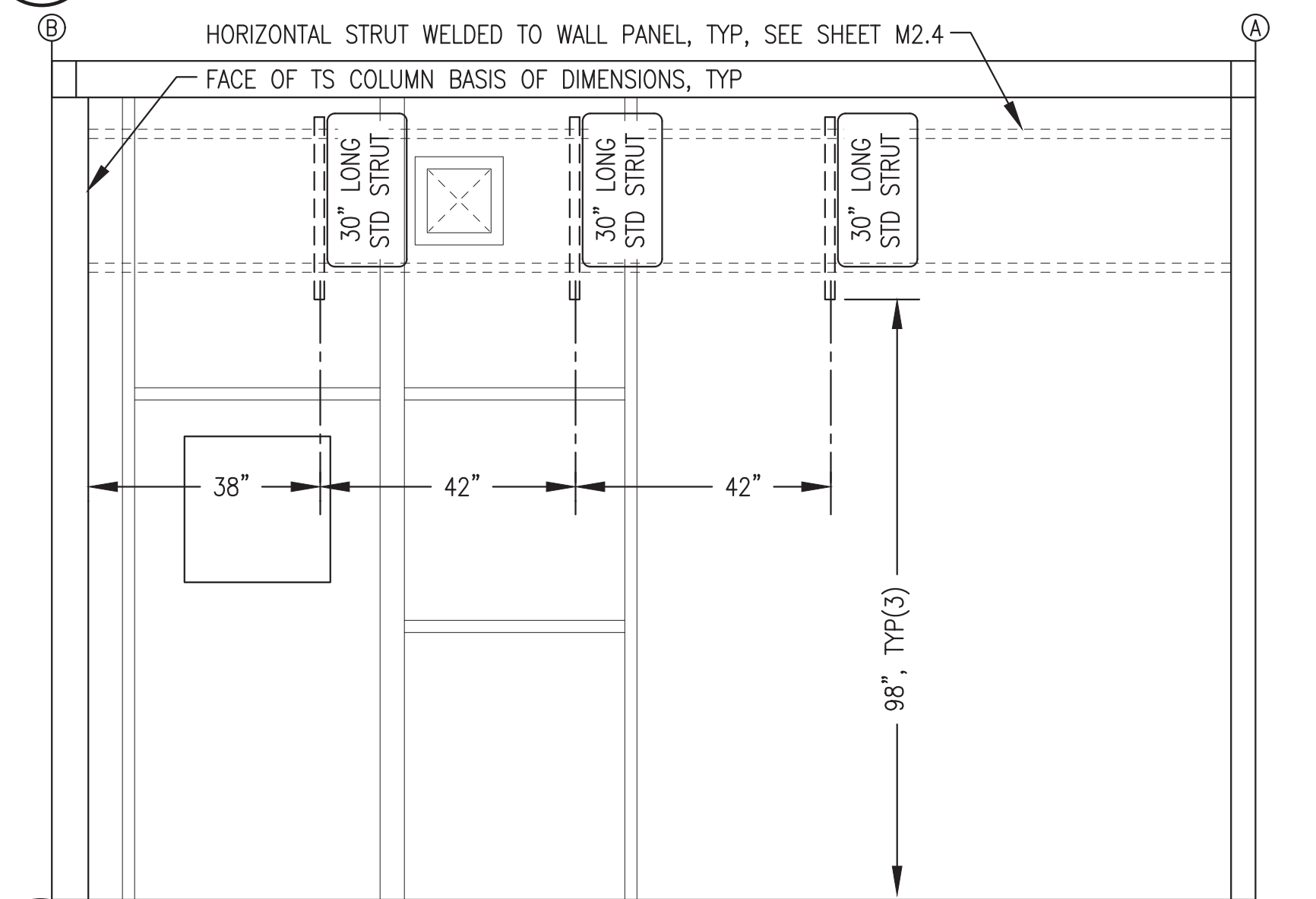

**6** CONTROL ROOM INTERIOR WALL VERTICAL WALL STRUT LAYOUT  
**M2.5** 1/2"=1'-0"

**VERTICAL WALL STRUT NOTES:**

- 1) ALL HORIZONTAL LOCATIONS ARE CENTERLINE OF STRUT FROM FACE OF TS COLUMNS. ALL VERTICAL LOCATIONS ARE END OF STRUT ABOVE FINISHED FLOOR.
- 2) ALL STRUT SHALL BE 12 GAUGE, PRE-GALVANIZED FINISH WITH SLOTTED BACK. "STD" DESIGNATES STANDARD 1-5/8" x 1-5/8" SINGLE STRUT, B-LINE B22-SH-GALV OR EQUAL. "DEEP" DESIGNATES 3-1/4" x 1-5/8" SINGLE STRUT, B-LINE B11-SH-GALV OR EQUAL.
- 3) FASTEN ALL VERTICAL STRUT SECTIONS TO HORIZONTAL STRUT WITH 1/2"x1" ALLEN HEAD CAP SCREWS & STRUT NUTS.
- 4) ONLY MAJOR WALL MOUNTED EQUIPMENT SUPPORT STRUT SHOWN THIS SHEET. SEE MECHANICAL AND ELECTRICAL DRAWINGS FOR OTHER EQUIPMENT, PIPING, AND WIREWAY STRUT SUPPORT DETAILS.

ISSUED FOR CONSTRUCTION  
 JULY 2022



ALL WORK ON THIS SHEET WAS PERFORMED AS PART OF THE PRIOR MODULE ASSEMBLY CONTRACT AND IS SHOWN HERE FOR REFERENCE ONLY.

<p>ALASKA ENERGY AUTHORITY</p>	
<p>PROJECT: NAPASKIAK POWER SYSTEM UPGRADE</p>	
<p>TITLE: MECHANICAL SUPPORT          VERTICAL WALL STRUT INSTALLATION</p>	
<p>DRAWN BY: JTD</p>	<p>SCALE: AS NOTED</p>
<p>DESIGNED BY: BCG</p>	<p>DATE: 7/29/22</p>
<p>FILE NAME: NAPS PP M2-7</p>	<p>SHEET: M2.5</p>
<p>P.O. 111405, Anchorage, AK 99511 (907)349-0100</p>	

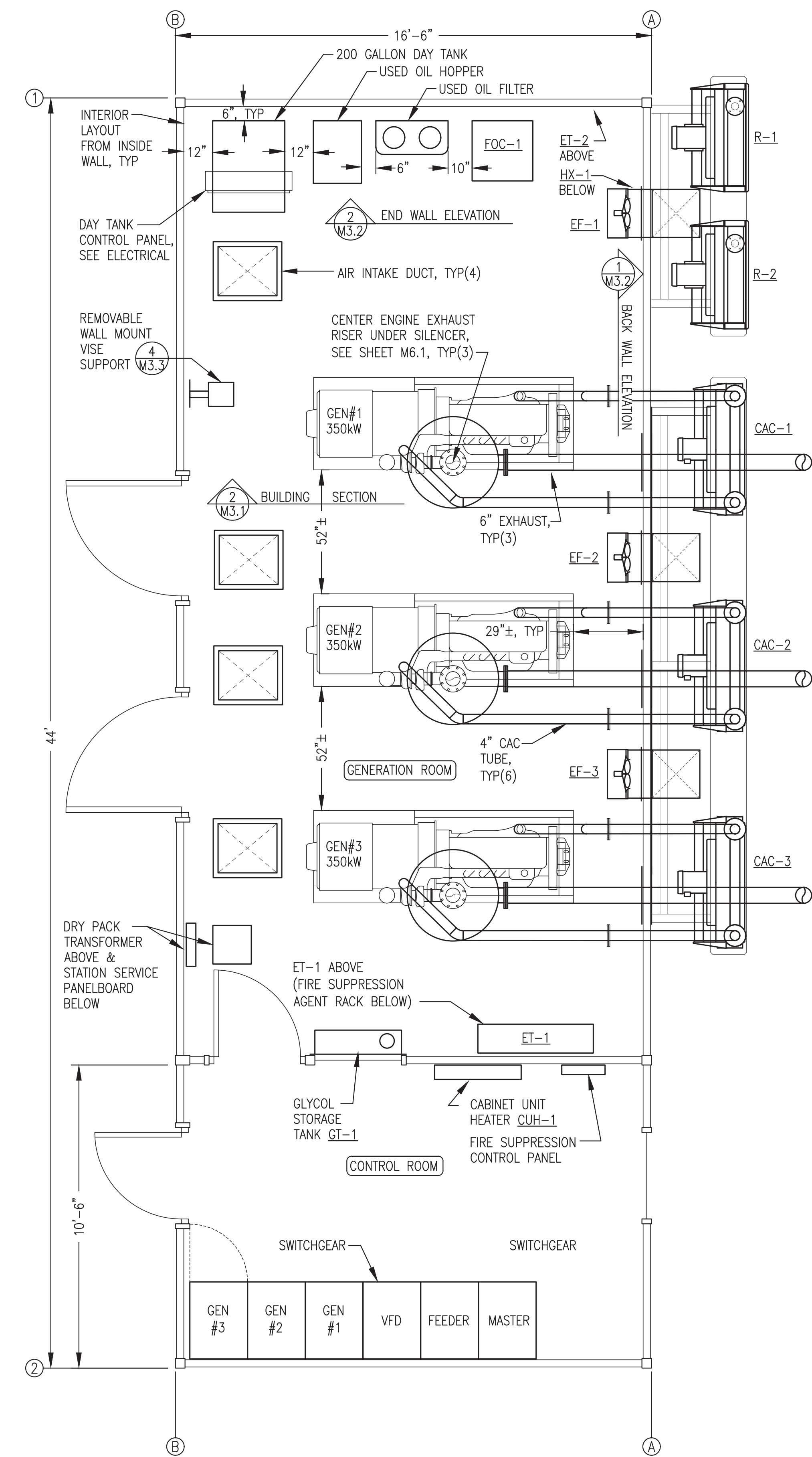

**1** EQUIPMENT LAYOUT PLAN  
**M3.1** 3/8"=1'-0"

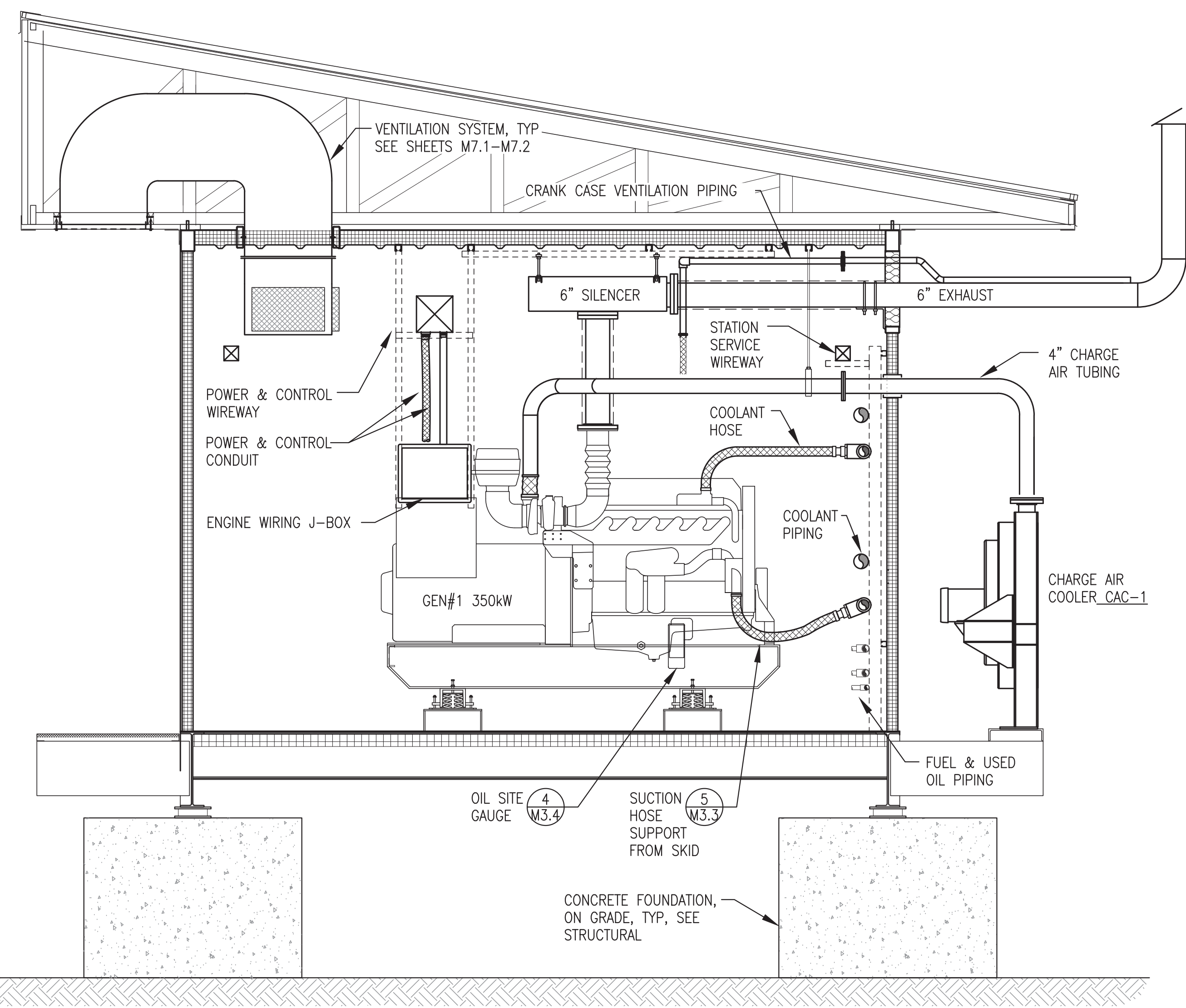

**2** TYPICAL MODULE SECTION AT GEN#1  
**M3.1** 1/2"=1'-0"

NOTE: ADJUST SPRING VIBRATION ISOLATOR LEVELING BOLTS TO ACHIEVE A UNIFORM INSTALLATION HEIGHT OF APPROXIMATELY 5-3/4" THEN TIGHTEN LOCKING NUTS. ADJUST NUTS ON STABILIZER BOLTS TO ACHIEVE A UNIFORM CLEARANCE OF APPROXIMATELY 1/8" THEN TIGHTEN LOCKING NUTS. VERIFY UNIT MOVES FREELY ON ISOLATORS.

LOCATE GENERATOR TO ALIGN WITH EXHAUST ABOVE PRIOR TO DRILLING PEDESTALS THEN FASTEN ISOLATOR TO PEDESTAL WITH 1/2" BOLTS

SEE SHEET M2.3 FOR SUPPORT PEDESTAL LOCATIONS & FABRICATION

**3** TYPICAL VIBRATION ISOLATOR INSTALLATION  
**M3.1** 1"=1'-0"

**EQUIPMENT LAYOUT GENERAL NOTES:**

- SEE M2 SHEETS FOR MECHANICAL AND ELECTRICAL SUPPORTS AND PENETRATIONS
- SEE M3 SHEETS FOR GENERAL EQUIPMENT LAYOUT, BASE SUPPORT, FABRICATIONS, AND GENERATOR ASSEMBLY DETAILS.
- SEE M4 SHEETS FOR ENGINE COOLANT SYSTEM AND HEAT RECOVERY SYSTEM PLANS, ISOMETRICS, AND DETAILS.
- SEE M5 SHEETS FOR DIESEL FUEL AND USED OIL SYSTEM PLANS AND DETAILS.
- SEE M6 SHEETS FOR EXHAUST, CRANK CASE VENTILATION, AND CHARGE AIR PLANS AND DETAILS.
- SEE M7 SHEETS FOR VENTILATION SYSTEM PLANS AND SHEET METAL FABRICATIONS.

ENGINE-GENERATOR SCHEDULE	
GENSET	DESCRIPTION
GEN #1, #2, & #3	ENGINE - 500 HP, 350 eKW PRIME, MTU-DETROIT 6063TK35. 24 VDC STARTING & CONTROL. GENERATOR - MINIMUM 450 KW CONTINUOUS AT 105°C RISE, NEWAGE/STAMFORD HC1534D.

**ENGINE-GENERATOR CODE COMPLIANCE NOTES**

- PER IMC 915.1 THE ENGINE-GENERATORS AND ASSOCIATED MECHANICAL SYSTEMS SHALL BE IN INSTALLED COMPLIANCE WITH NFPA 37. SEE THE ABOVE REFERENCED DRAWINGS FOR ADDITIONAL DETAIL.
- PER IMC 915.1 THE ENGINE-GENERATORS SHALL BE FABRICATED AND ASSEMBLED IN ACCORDANCE WITH U.L. 2200. SEE ENGINE-GENERATOR SPECIFICATIONS FOR ADDITIONAL DETAIL.

ISSUED FOR CONSTRUCTION  
 JULY 2022

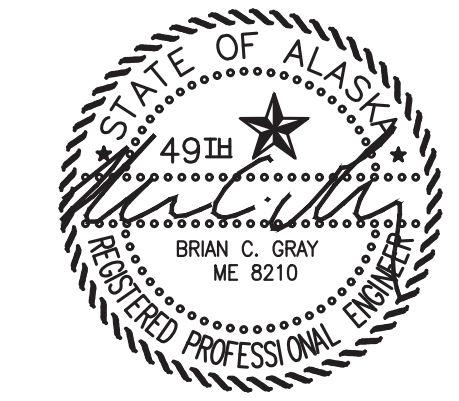

**ALASKA ENERGY AUTHORITY**

PROJECT: **NAPASKIAK POWER SYSTEM UPGRADE**

TITLE: **EQUIPMENT LAYOUT PLAN, SECTION, & DETAILS**

 Gray Stassel Engineering, Inc. P.O. 111405, Anchorage, AK 99511 (907)349-0100	DRAWN BY: JTD DESIGNED BY: BCG FILE NAME: NAPS PP M2-7 PROJECT NUMBER:	SCALE: AS NOTED DATE: 7/29/22 SHEET: <b>M3.1</b>
--	---	---

THE MAJORITY OF WORK ON THIS SHEET WAS PERFORMED AS PART OF THE PRIOR MODULE ASSEMBLY CONTRACT AND IS SHOWN HERE FOR REFERENCE ONLY. FIELD INSTALLATION OF COMPONENTS EXTERIOR TO THE MODULE UNDER THE ON SITE CONTRACT ARE DELINEATED ON SHEETS THAT FOLLOW.



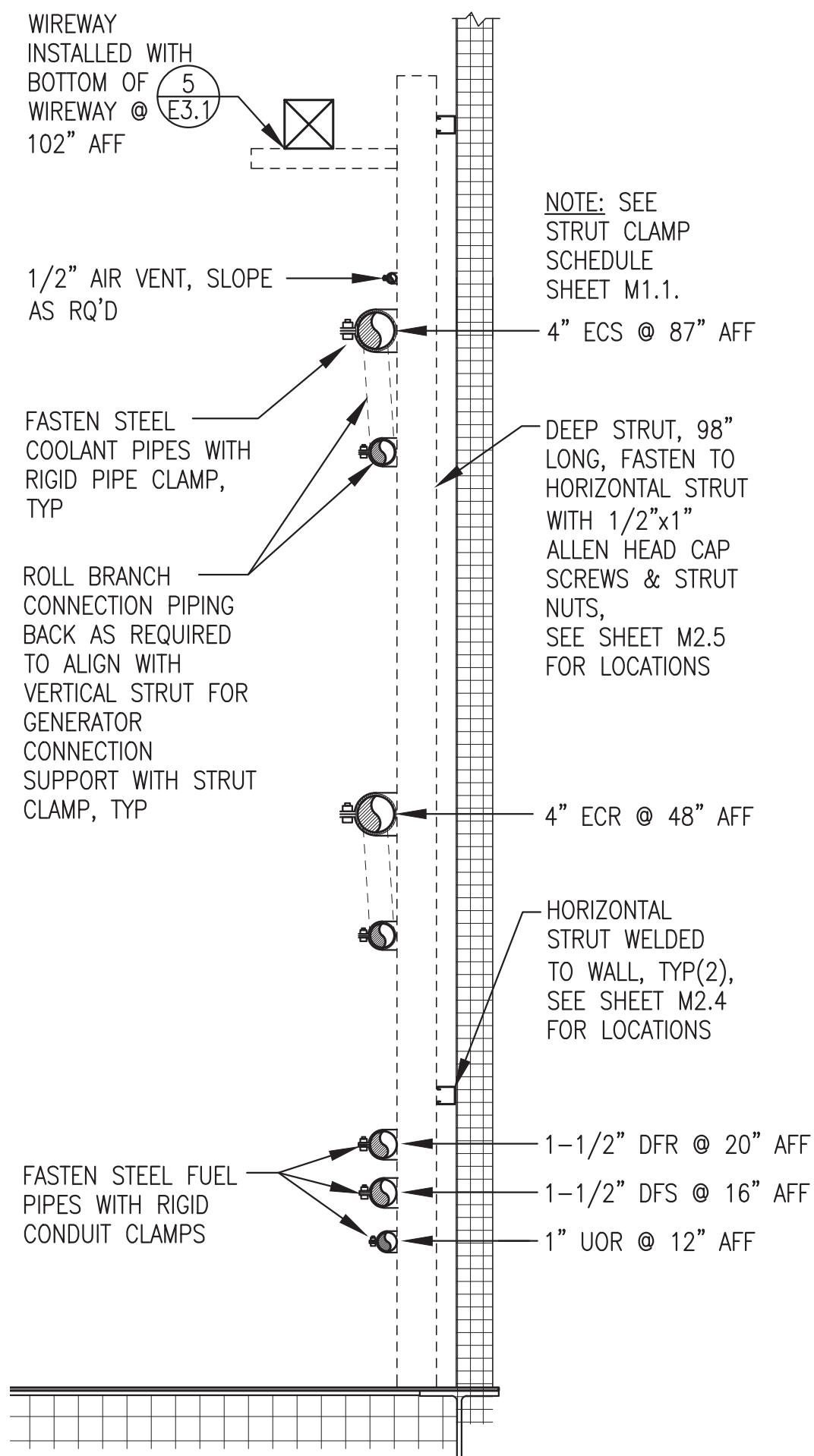

**1** TYPICAL PIPE SUPPORT AT BACK WALL  
 M3.3 1"=1'-0"

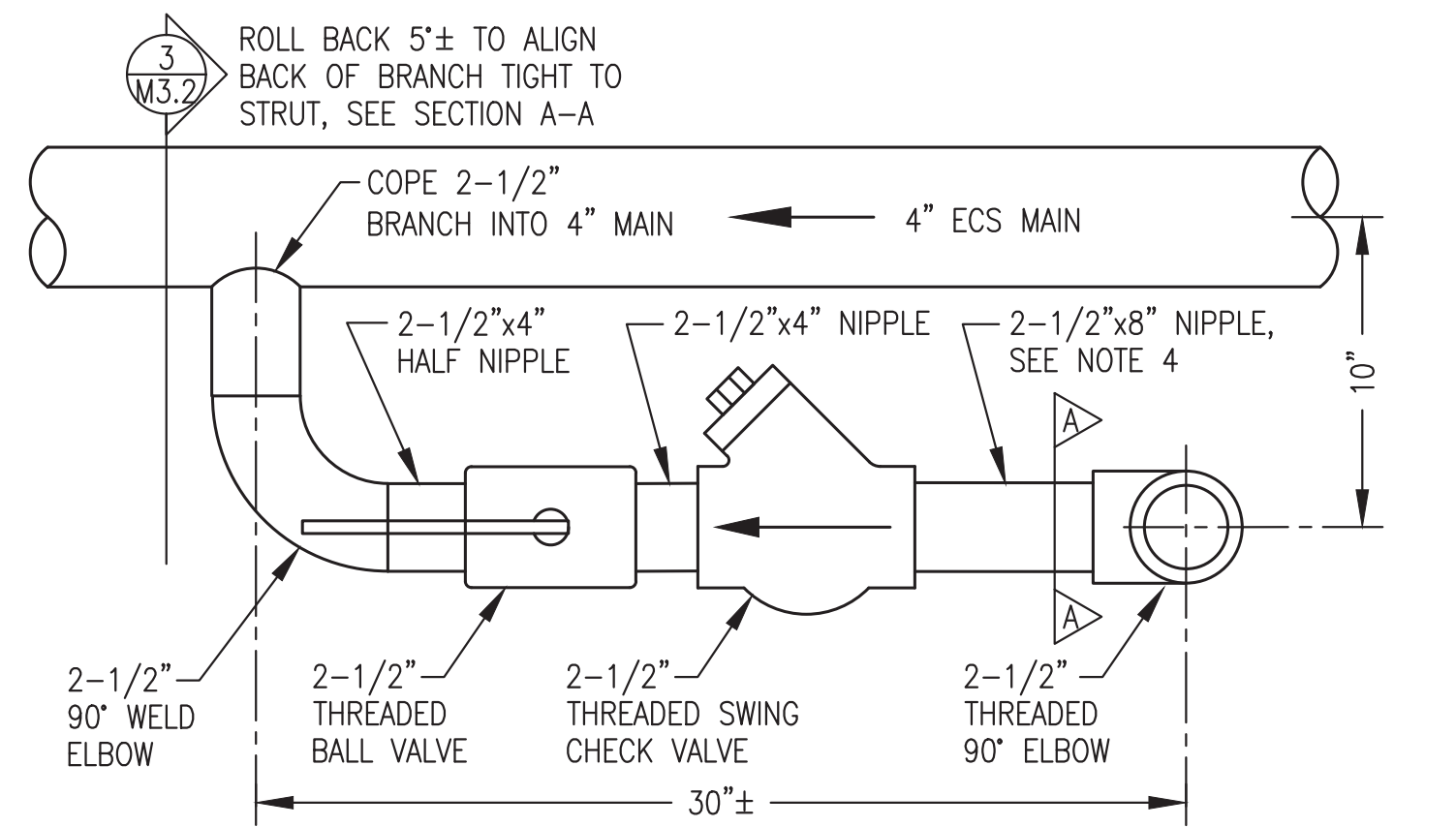

- NOTES:  
 1) GEN#2 & GEN#3 DISCHARGE CONNECTION SHOWN, GEN#1 MIRROR IMAGE  
 2) MAIN PIPING 4" STEEL WITH 1" INSULATION. ALL BRANCH PIPING NOT INSULATED.  
 3) ALL PIPING SCHEDULE 40 STEEL.  
 4) ADJUST NIPPLE LENGTH AS REQUIRED TO PROVIDE FOR 30"± OVERALL LENGTH AND TO ENSURE EXPOSED PIPE SECTION ALIGNED WITH STRUT FOR CLAMP.

**2** GEN#2/GEN#3 DISCHARGE CONNECTION (GEN#1 MIRROR IMAGE)  
 M3.3 NO SCALE

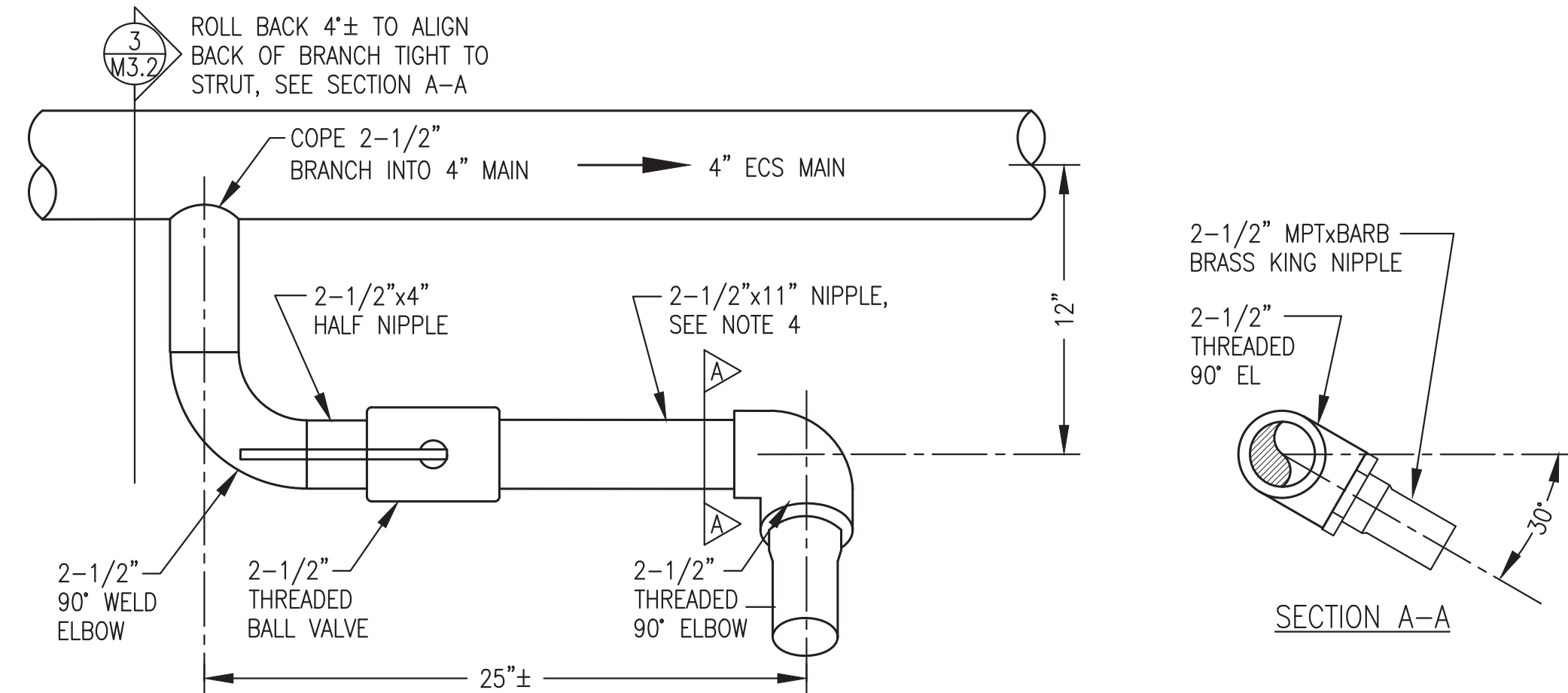

- NOTES:  
 1) GEN#2 & GEN#3 SUCTION CONNECTION SHOWN, GEN#1 MIRROR IMAGE  
 2) MAIN PIPING 4" STEEL WITH 1" INSULATION. ALL BRANCH PIPING NOT INSULATED.  
 3) ALL PIPING SCHEDULE 40 STEEL.  
 4) ADJUST NIPPLE LENGTH AS REQUIRED TO PROVIDE FOR 24"± OVERALL LENGTH AND TO ENSURE EXPOSED PIPE SECTION ALIGNED WITH STRUT FOR CLAMP.

**3** GEN#2/GEN#3 SUCTION CONNECTION (GEN#1 MIRROR IMAGE)  
 M3.3 NO SCALE

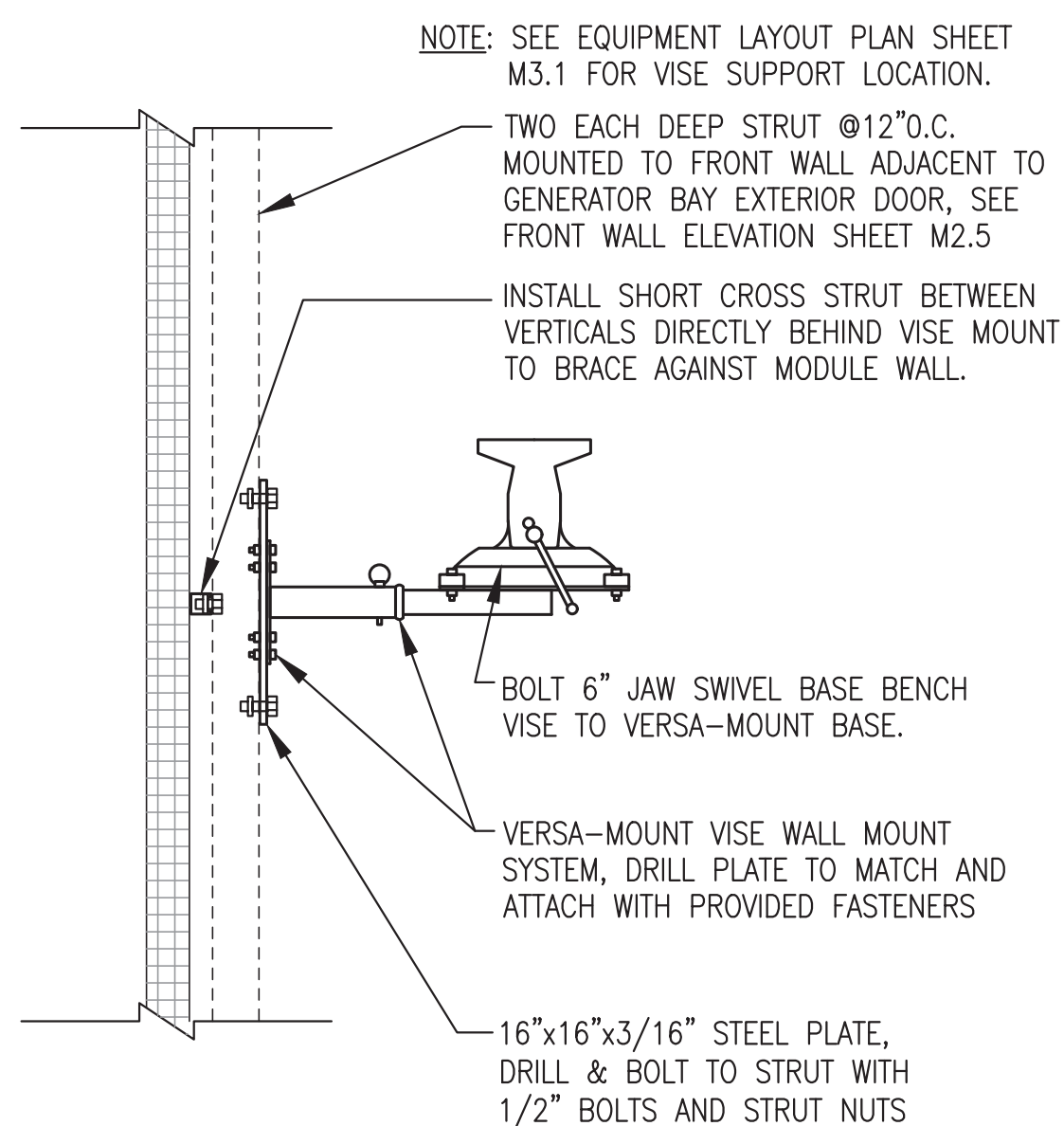

**4** REMOVABLE BENCH VISE INSTALLATION  
 M3.3 NO SCALE

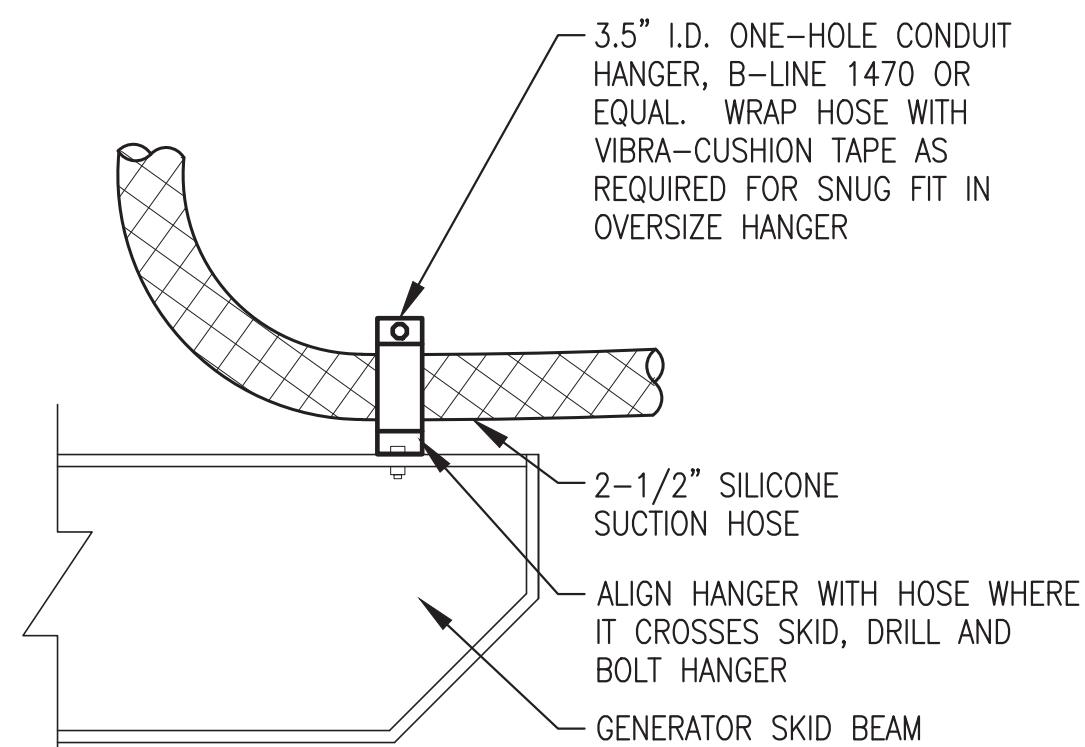

**5** TYPICAL GENERATOR SUCTION HOSE SUPPORT  
 M3.3 NO SCALE

ALL WORK ON THIS SHEET WAS PERFORMED AS PART OF THE PRIOR MODULE ASSEMBLY CONTRACT AND IS SHOWN HERE FOR REFERENCE ONLY.

ISSUED FOR CONSTRUCTION  
 JULY 2022

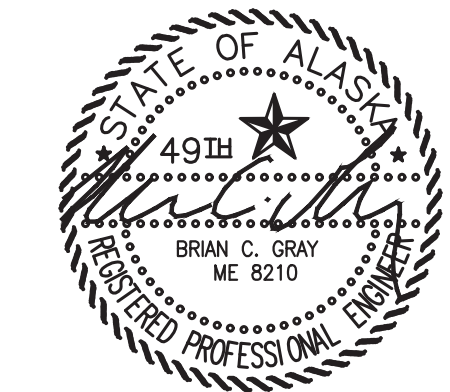

PROJECT: NAPASKIAK POWER SYSTEM UPGRADE		
TITLE: MECHANICAL DETAILS		
 P.O. 111405, Anchorage, AK 99511 (907)349-0100	DRAWN BY: JTD DESIGNED BY: BCG FILE NAME: NAPS PP M2-7 PROJECT NUMBER:	SCALE: AS NOTED DATE: 7/29/22 SHEET: <b>M3.3</b>

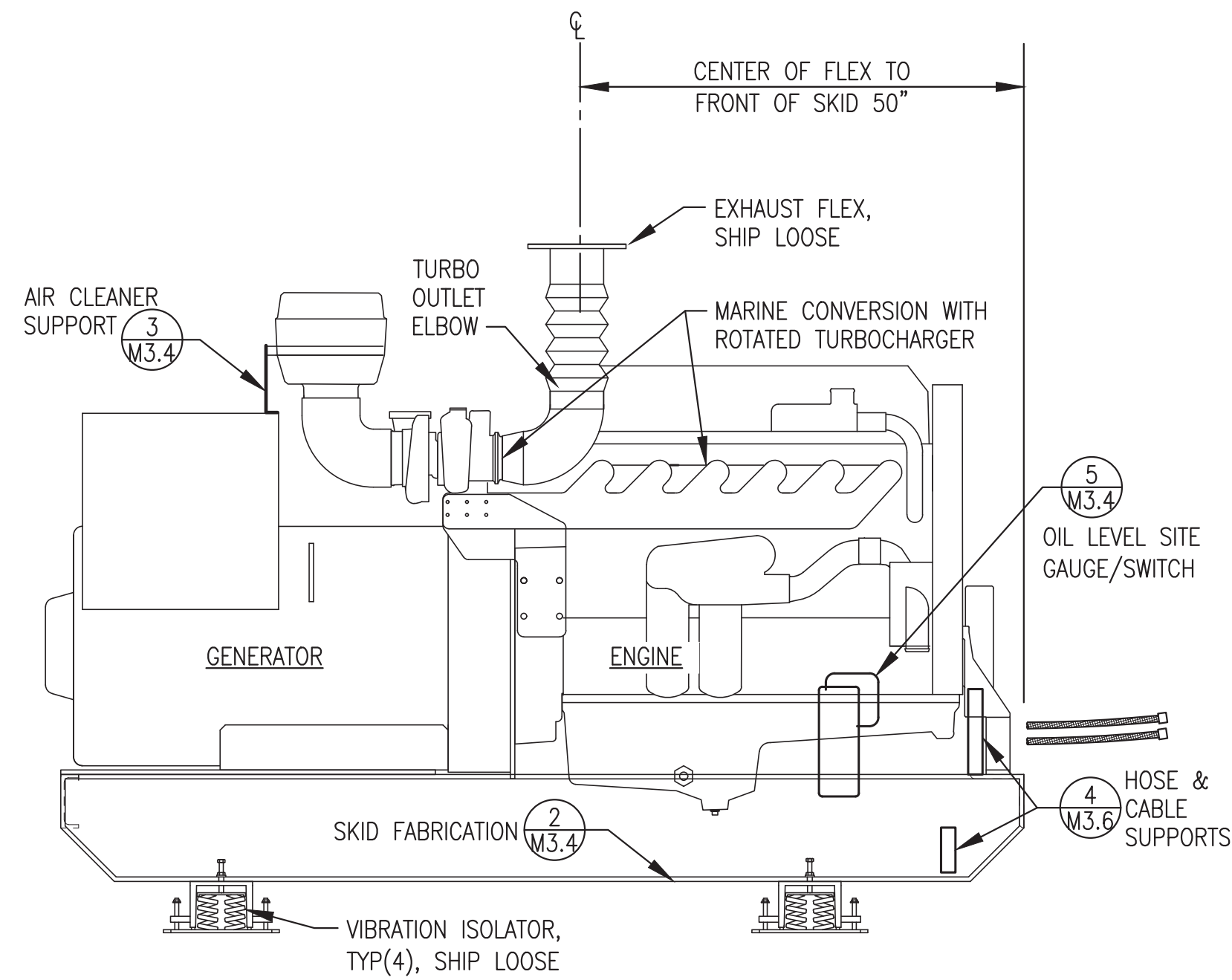

**1** TYPICAL GENERATOR ASSEMBLY  
**M3.4** 3/4"=1'-0"

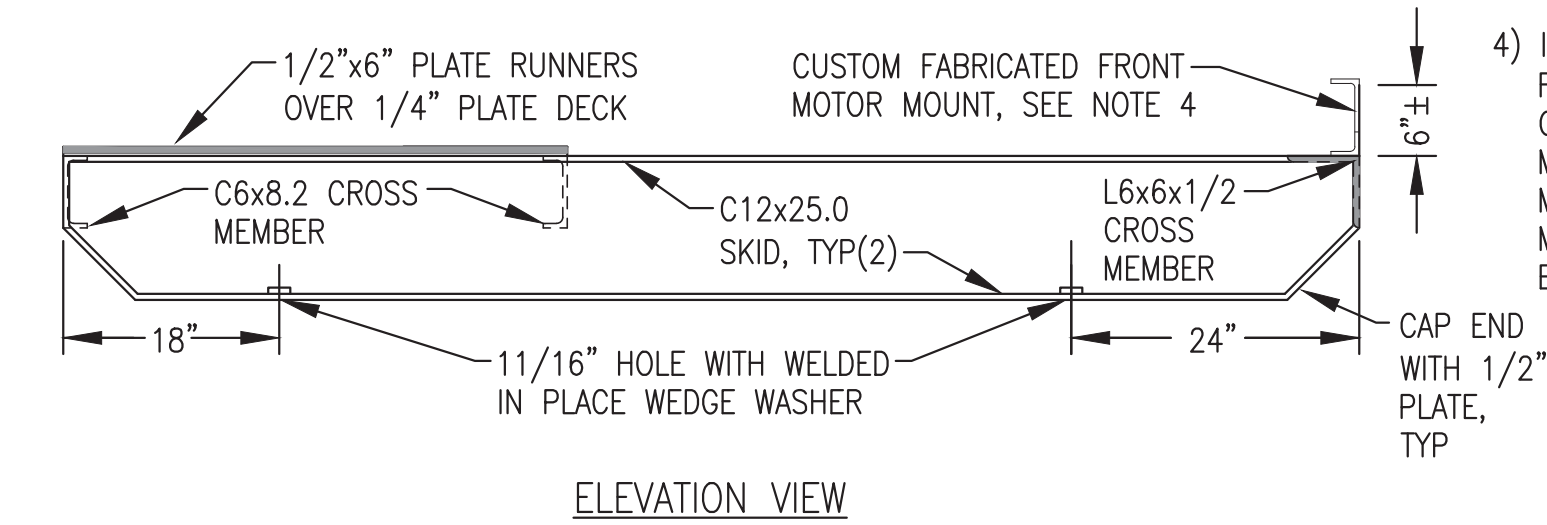
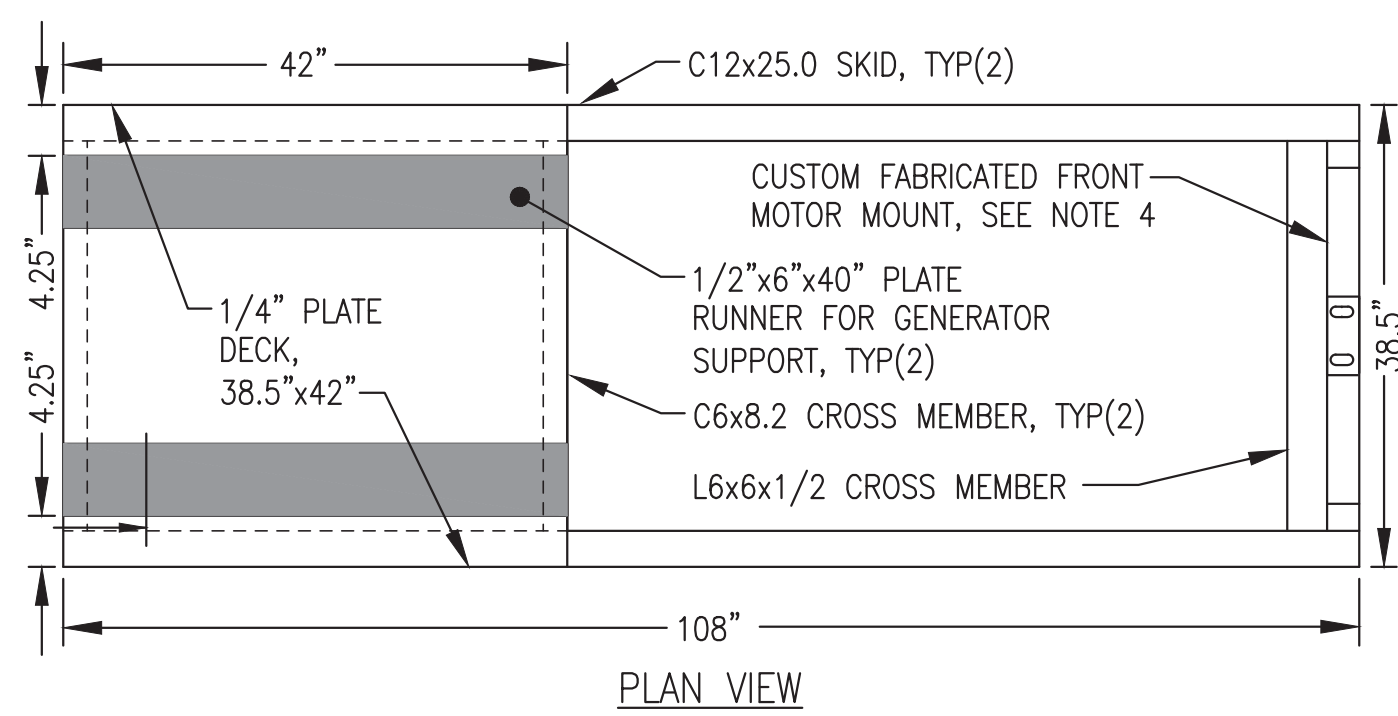

**2** TYPICAL GENERATOR SKID FABRICATION  
**M3.4** 3/4"=1'-0"

- SKID FABRICATION NOTES:**
- 1) FABRICATE FROM ASTM A-36 STEEL.
  - 2) MAKE ALL CONNECTIONS WITH CONTINUOUS WELDS (FILLET OR FULL-PENETRATION GROOVE AS REQUIRED) IN ACCORDANCE WITH CURRENT AWS STANDARD CODE.
  - 3) ROUND ALL CORNERS & GRIND WELDS SMOOTH AFTER FABRICATION. PAINT IN ACCORDANCE WITH SPECIFICATIONS.
  - 4) INSTALL CUSTOM FABRICATED STEEL CHANNEL CROSS MEMBER & FACTORY MOTOR MOUNT TO MATCH GENERATOR ELEVATION.

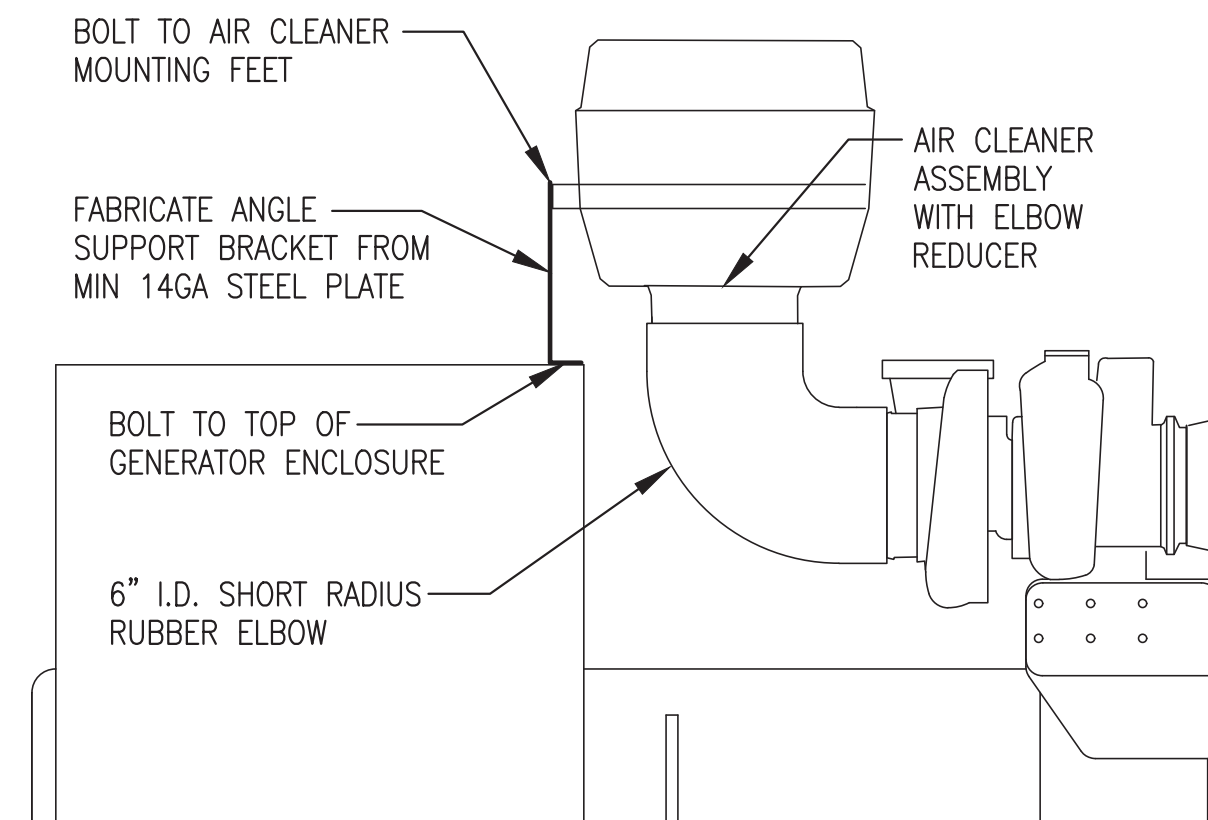

**3** TYPICAL GENERATOR AIR CLEANER INSTALLATION  
**M3.4** 3/4"=1'-0"

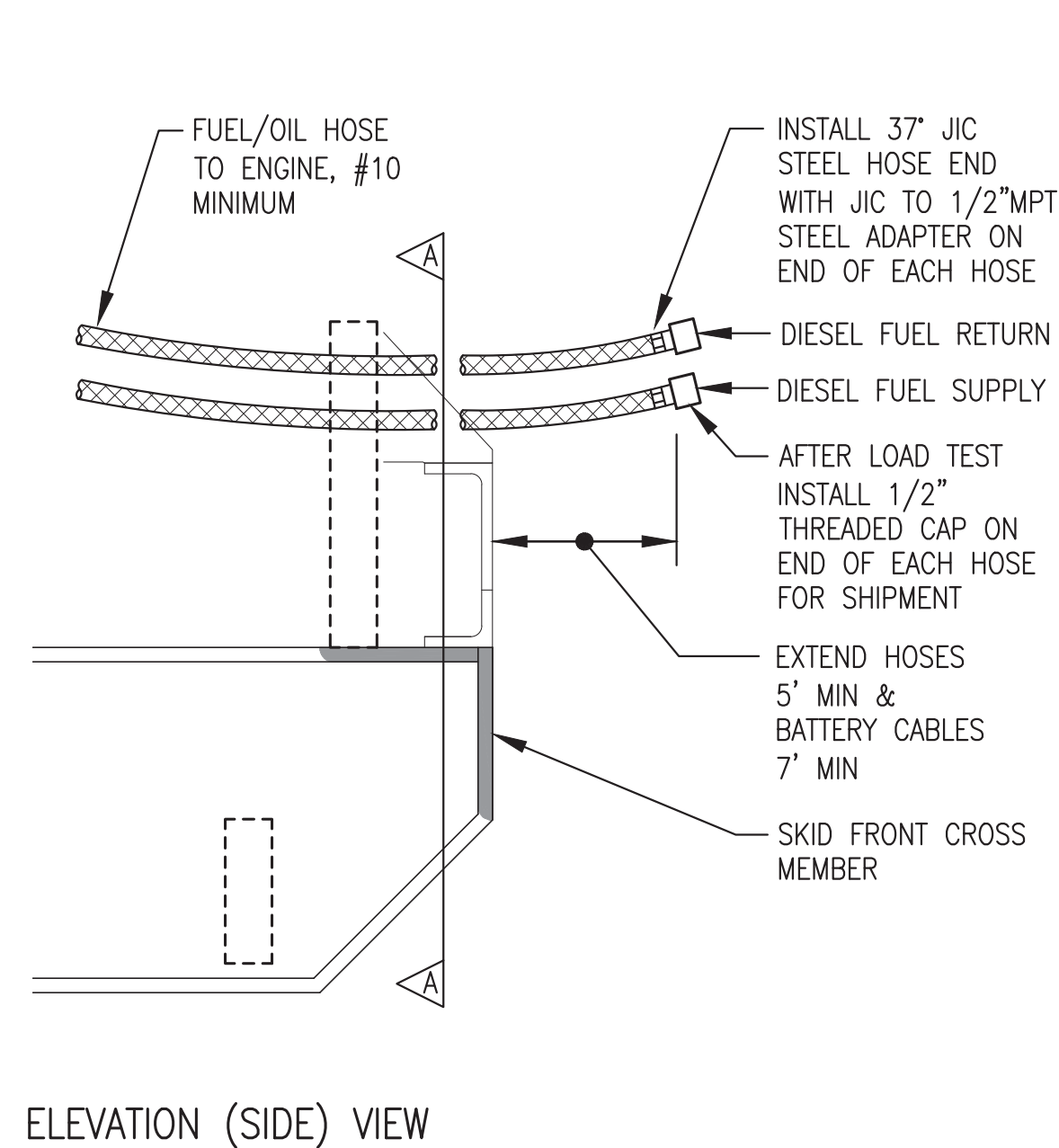

**4** TYPICAL SKID FUEL/OIL HOSE & BATTERY CABLE SUPPORT  
**M3.4** NO SCALE

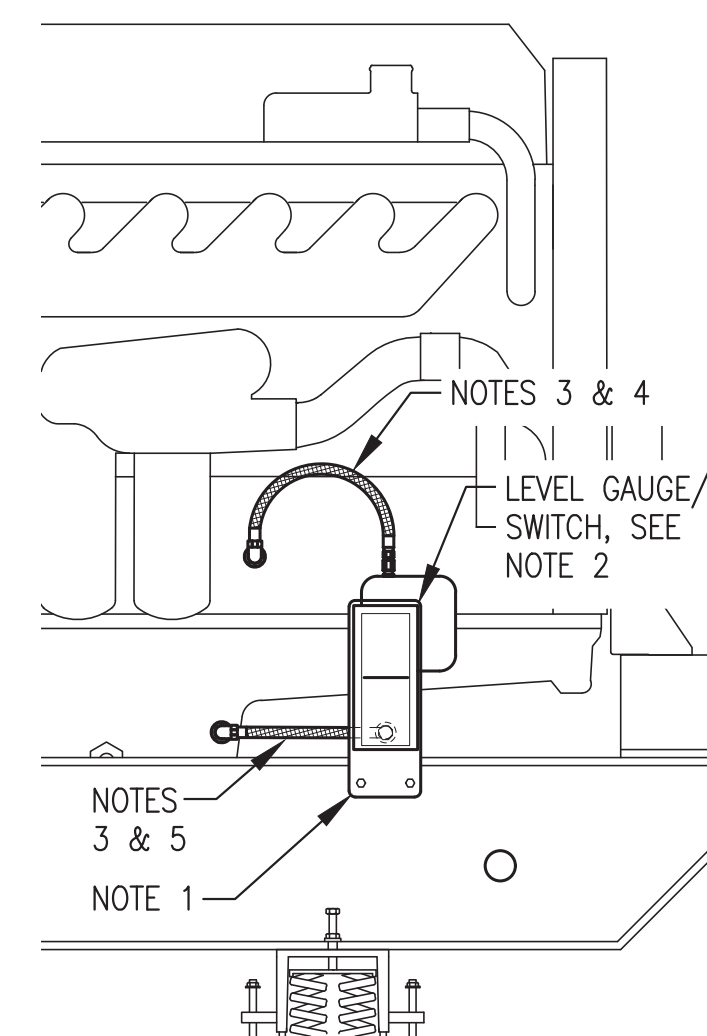
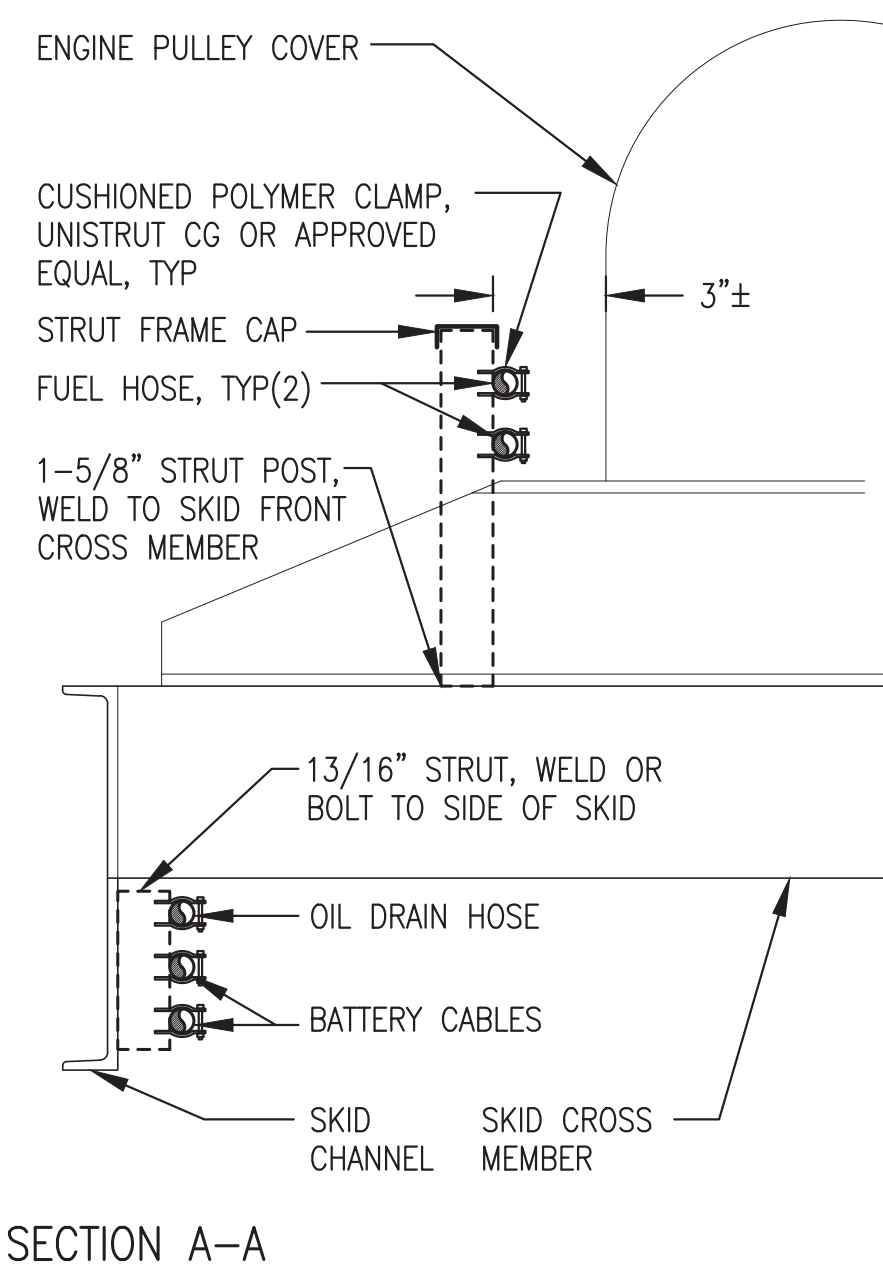

**5** TYPICAL OIL LEVEL GAUGE/SWITCH INSTALLATION  
**M3.4** 1"=1'-0"

- NOTES:**
- 1) 1/4" STEEL SUPPORT PLATE PRE-DRILLED TO MATCH GAUGE/SWITCH MOUNTS, CHANNEL SKID HOLES AND BOTTOM HOSE ENTRANCE. BOLT TO INSIDE (BACK) OF CHANNEL SKID AT HEIGHT AS REQUIRED TO CENTER GAUGE AT NORMAL FULL OIL LEVEL. ADJUST SWITCH CONTACTS 1/2" ABOVE & BELOW.
  - 2) MOUNT OIL LEVEL GAUGE/SWITCH TO STEEL SUPPORT PLATE WITH RUBBER SHOCK MOUNTS.
  - 3) #8 HOSE WITH 1/2" OR 3/8" NPT JIC SWIVEL ENDS AS REQUIRED.
  - 4) CONNECT TOP (VENT) PORT TO ENGINE CRANK CASE WITH HOSE. ROUTE UPPER HOSE WITH HIGH POINT 4" MIN ABOVE TOP OF FLOAT SWITCH.
  - 5) CONNECT BOTTOM PORT TO ENGINE OIL PAN WITH HOSE. DO NOT TEE INTO OIL DRAIN LINE. ROUTE LOWER HOSE BACK THROUGH PRE-DRILLED HOLE IN STEEL PLATE.

ALL WORK ON THIS SHEET WAS PERFORMED AS PART OF THE PRIOR MODULE ASSEMBLY CONTRACT AND IS SHOWN HERE FOR REFERENCE ONLY.

ISSUED FOR CONSTRUCTION  
 JULY 2022



PROJECT: NAPASKIAK POWER SYSTEM UPGRADE		
TITLE: GENERATOR FABRICATION DETAILS		
DRAWN BY: JTD	SCALE: AS NOTED	
DESIGNED BY: BCG	DATE: 7/29/22	
FILE NAME: NAPS PP M2-7	SHEET:	<b>M3.4</b>
PROJECT NUMBER:		

P.O. 111405, Anchorage, AK 99511 (907)349-0100

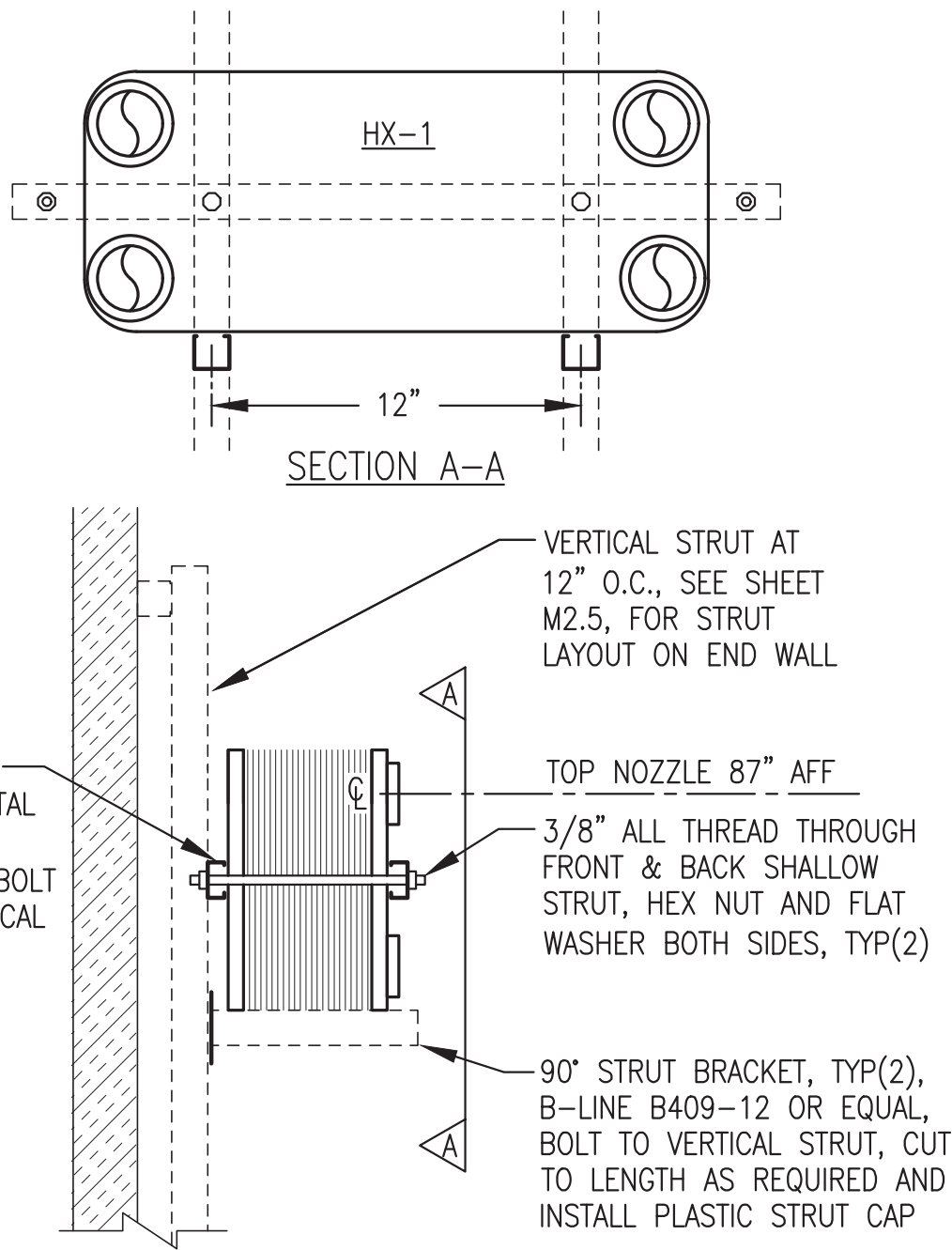
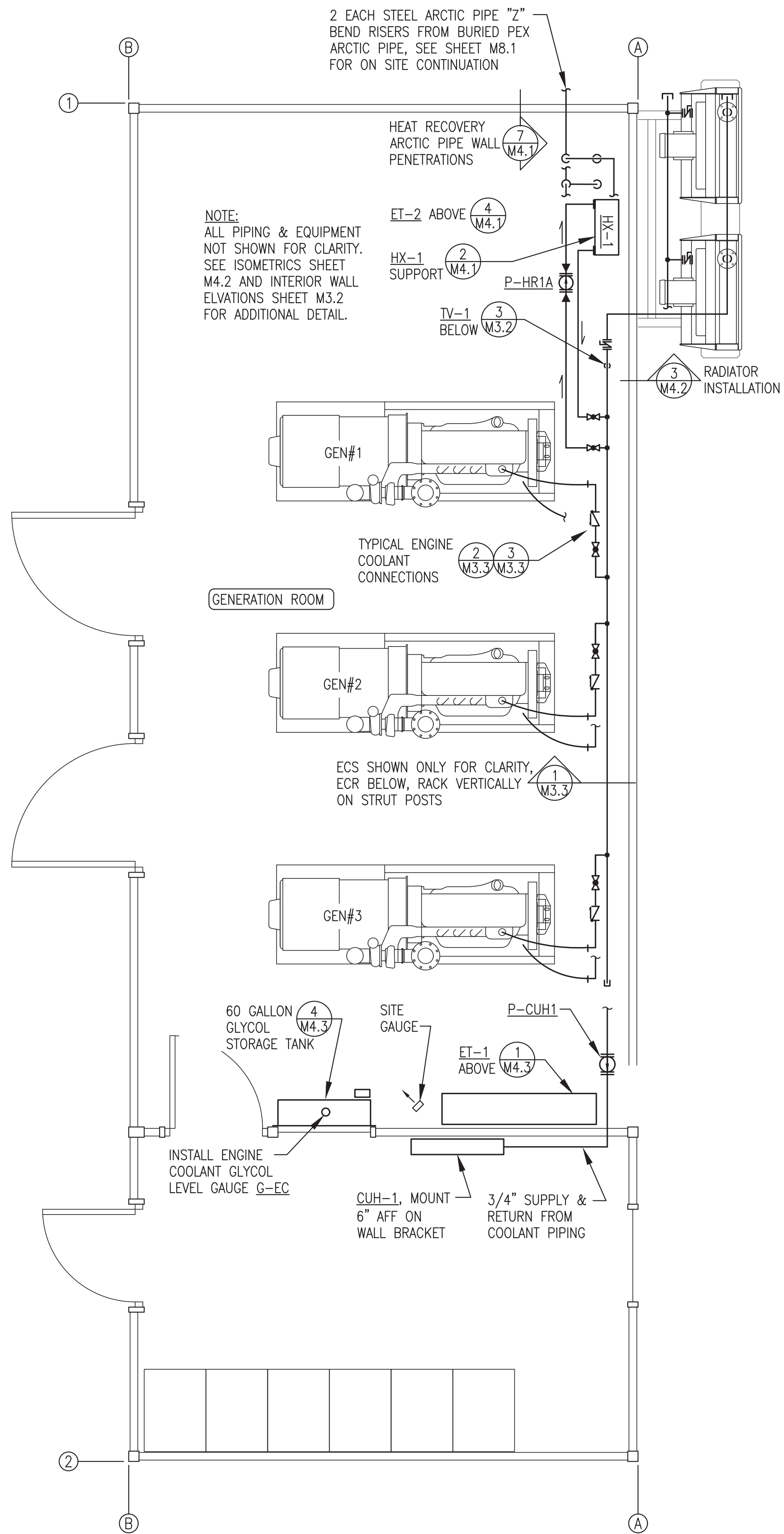

2 HEAT EXCHANGER HX-1 SUPPORT FROM WALL  
M4.1 NO SCALE

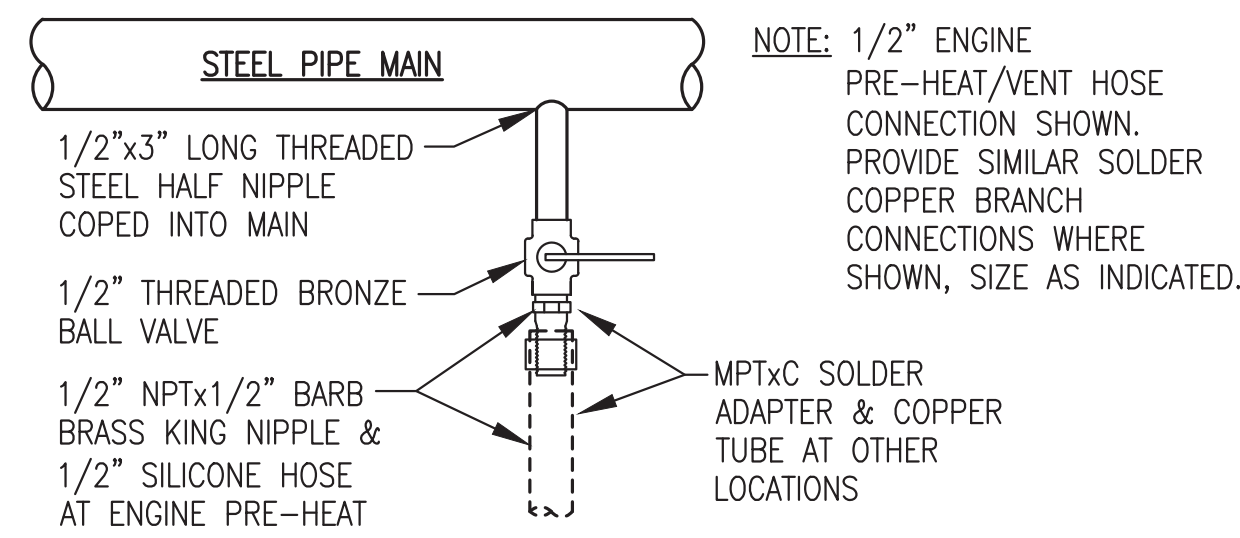

5 TYP VALVED BRANCH CONNECTION TO STEEL MAIN  
M4.1 NO SCALE

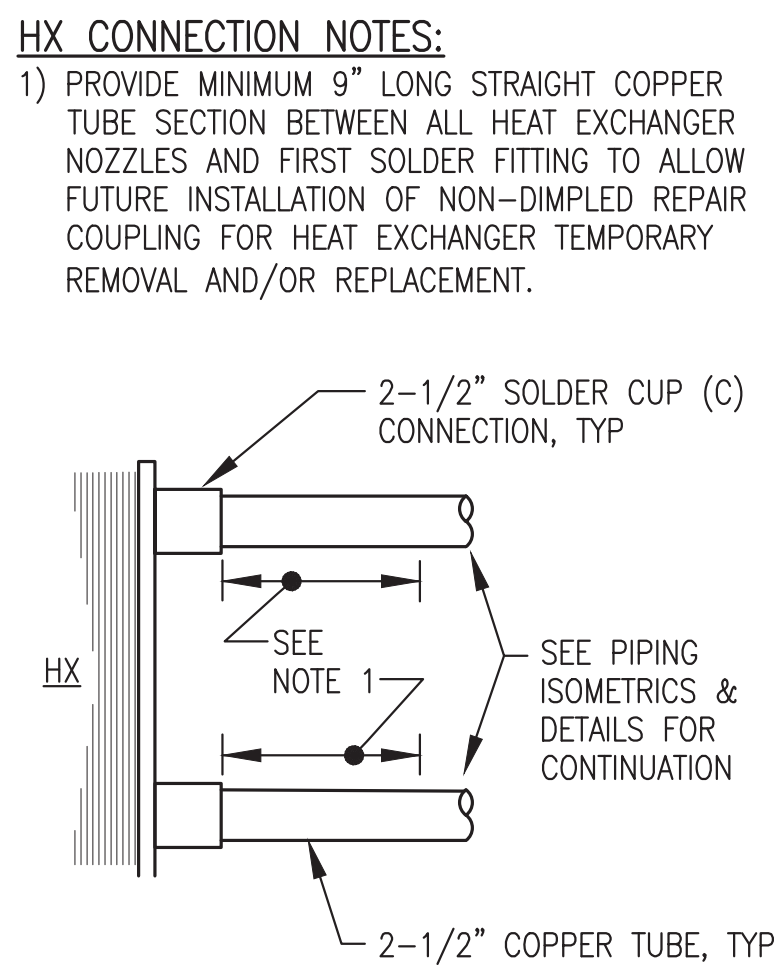

3 TYPICAL HX PIPING CONNECTION  
M4.1 NO SCALE

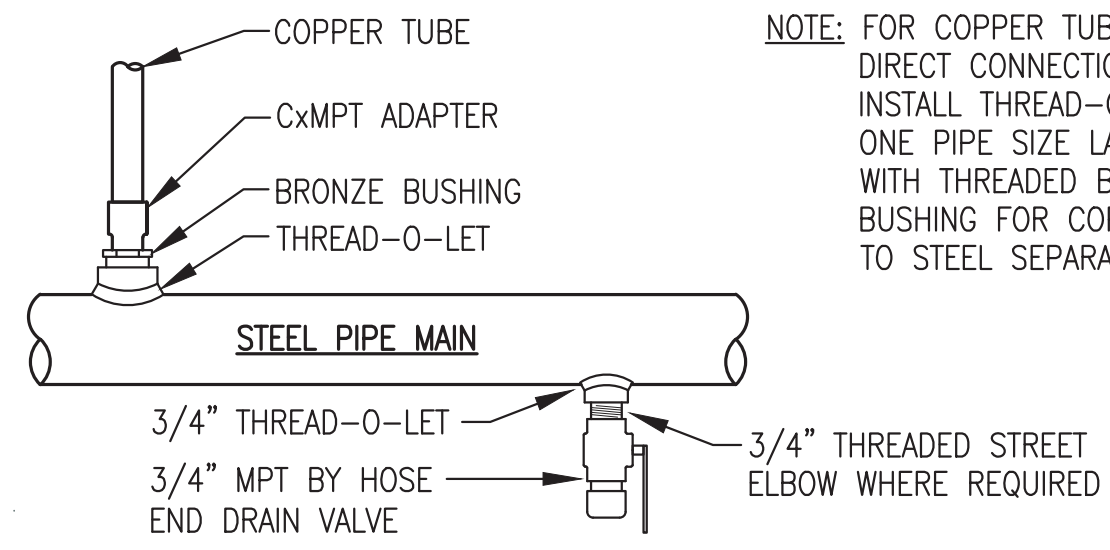

6 TYP DIRECT CONNECTION TO STEEL MAIN  
M4.1 NO SCALE

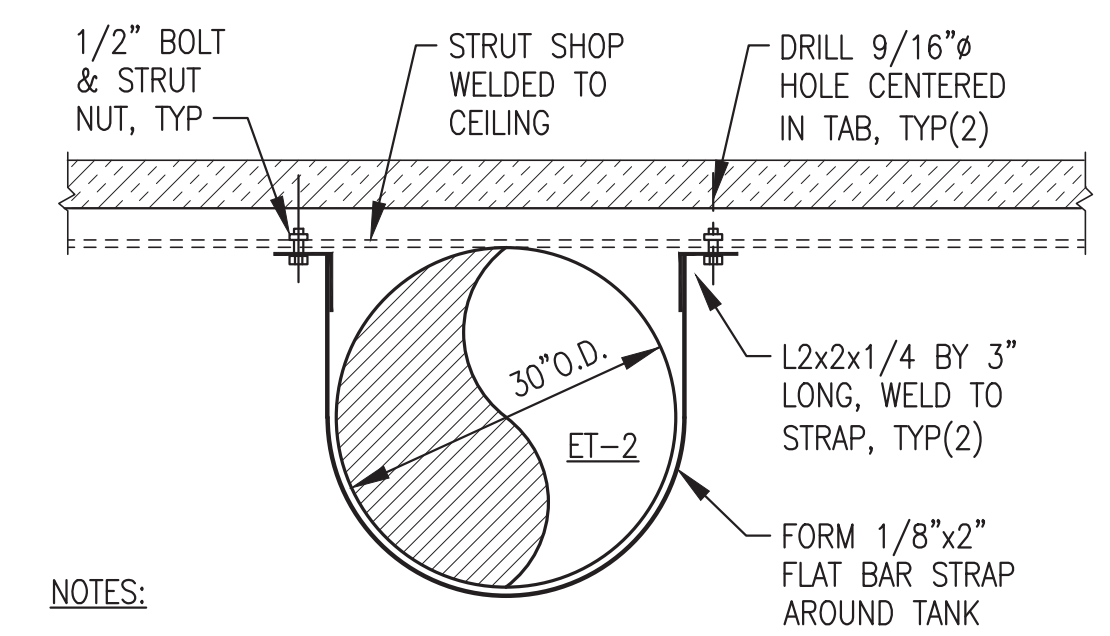

4 HEAT RECOVERY EXP TANK ET-2 SUPPORT  
M4.1 NO SCALE

NOTES:  
1) SMOOTH EDGES AFTER FABRICATION, WIRE BRUSH, SOLVENT CLEAN, AND PAINT WITH TWO COATS OF COLD GALVANIZING COMPOUND.  
2) ONE STRAP SHOWN. INSTALL FIVE IDENTICAL STRAPS.

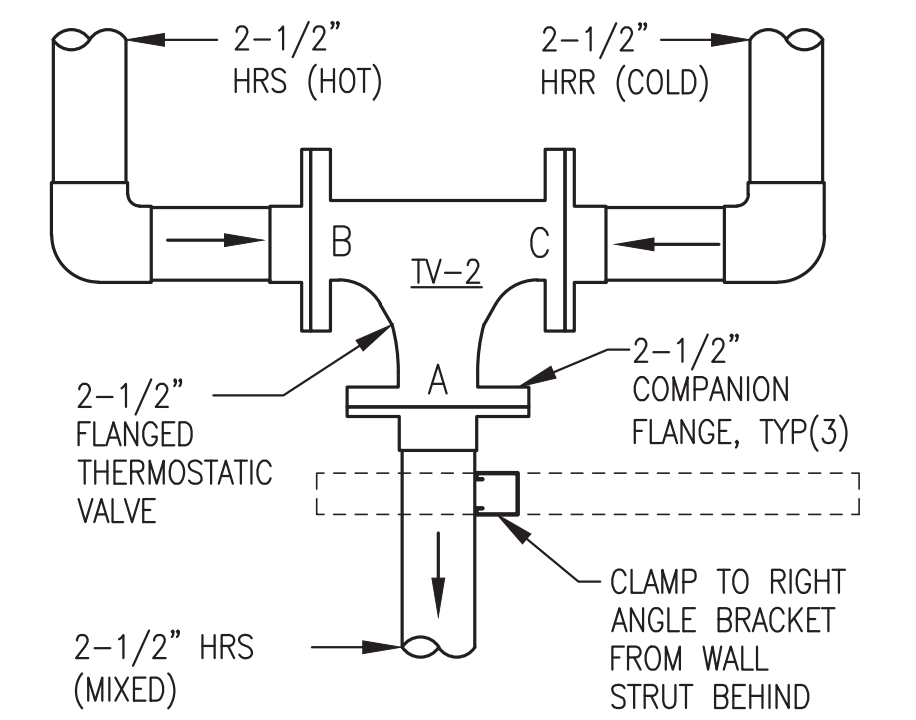

8 TV-2 INSTALLATION  
M4.1 NO SCALE

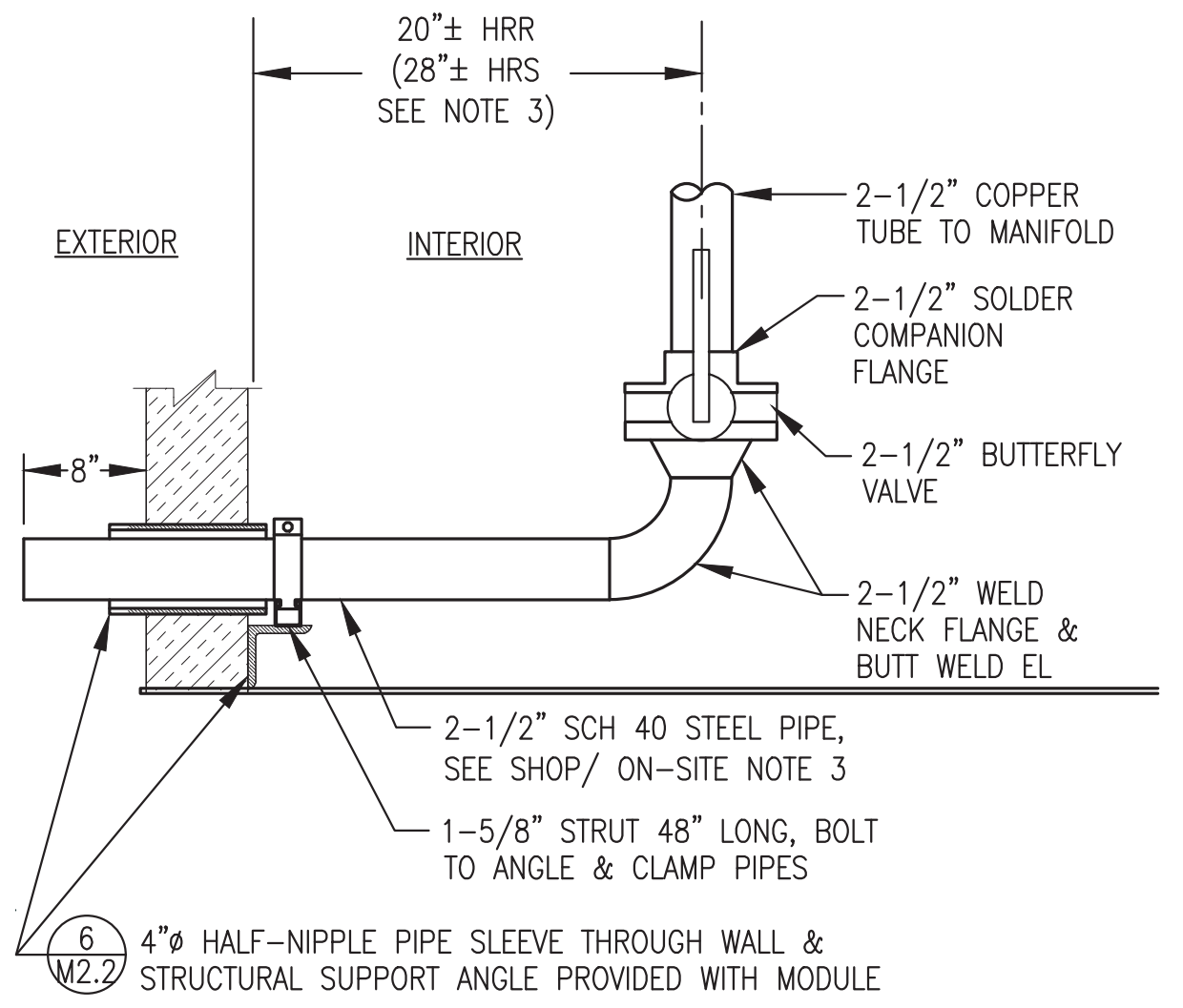

7 HEAT RECOVERY ARCTIC PIPE WALL PENETRATIONS  
M4.1 NO SCALE

- ARCTIC PIPE GENERAL NOTES:**
- SEE END WALL ELEVATION 2/M3.2 FOR PIPE WALL PENETRATION LAYOUT.
  - ONE PIPE SHOWN. PROVIDE TWO SIMILAR.
  - 2-1/2" HR SUPPLY TO RISE UP DIRECTLY INTO TV-2 "A" PORT, SEE BACK WALL ELEVATION 1/M3.2.
- ARCTIC PIPE SHOP/ON-SITE NOTES:**
- SHOP INSTALLATION SHOWN. STUB PIPE 8" MIN BEYOND WALL & TEMPORARILY CONNECT SUPPLY TO RETURN FOR TESTING.
  - AS PART OF ON-SITE PREP FOR SHIPPING REMOVE TEMPORARY CONNECTION, BREAK FLANGE JOINT, & STORE PIPE IN MODULE. BRACE BUTTERFLY VALVE AS REQUIRED & INSTALL 4" THREADED PIPE CAP FOR SHIPPING.
  - IN FIELD REMOVE THREADED PIPE CAP, REINSTALL PIPE THROUGH WALL & CONNECT TO ARCTIC PIPE, SEE SHEET M8.
  - SHOP INSULATE COPPER TUBE UP TO BUTTERFLY VALVE. SHOP CUT & FIT INSULATION & JACKET FOR STEEL PIPE TO WALL BUT SHIP LOOSE FOR FIELD INSTALLATION.

ALL WORK ON THIS SHEET WAS PERFORMED AS PART OF THE PRIOR MODULE ASSEMBLY CONTRACT EXCEPT AS SPECIFICALLY INDICATED IN THE SHOP/ON SITE NOTES.

1 COOLANT AND HEAT RECOVERY PIPING PLAN  
M4.1 3/8"=1'-0"

REVISION #1  
ISSUED  
AUGUST 2022



1	REVISED TO COORDINATE WITH FINAL ON-SITE DESIGN	8/26/22	BCG
REV.	DESCRIPTION	DATE	BY
<p>ALASKA ENERGY AUTHORITY</p>			
PROJECT: NAPASKIAK POWER SYSTEM UPGRADE			
TITLE: COOLANT & HEAT RECOVERY PIPING PLAN & DETAILS			
DRAWN BY: JTD		SCALE: AS NOTED	
DESIGNED BY: BCG		DATE: 7/29/22	
FILE NAME: NAPS PP M2-7		SHEET: M4.1	
P.O. 111405, Anchorage, AK 99511 (907)349-0100			



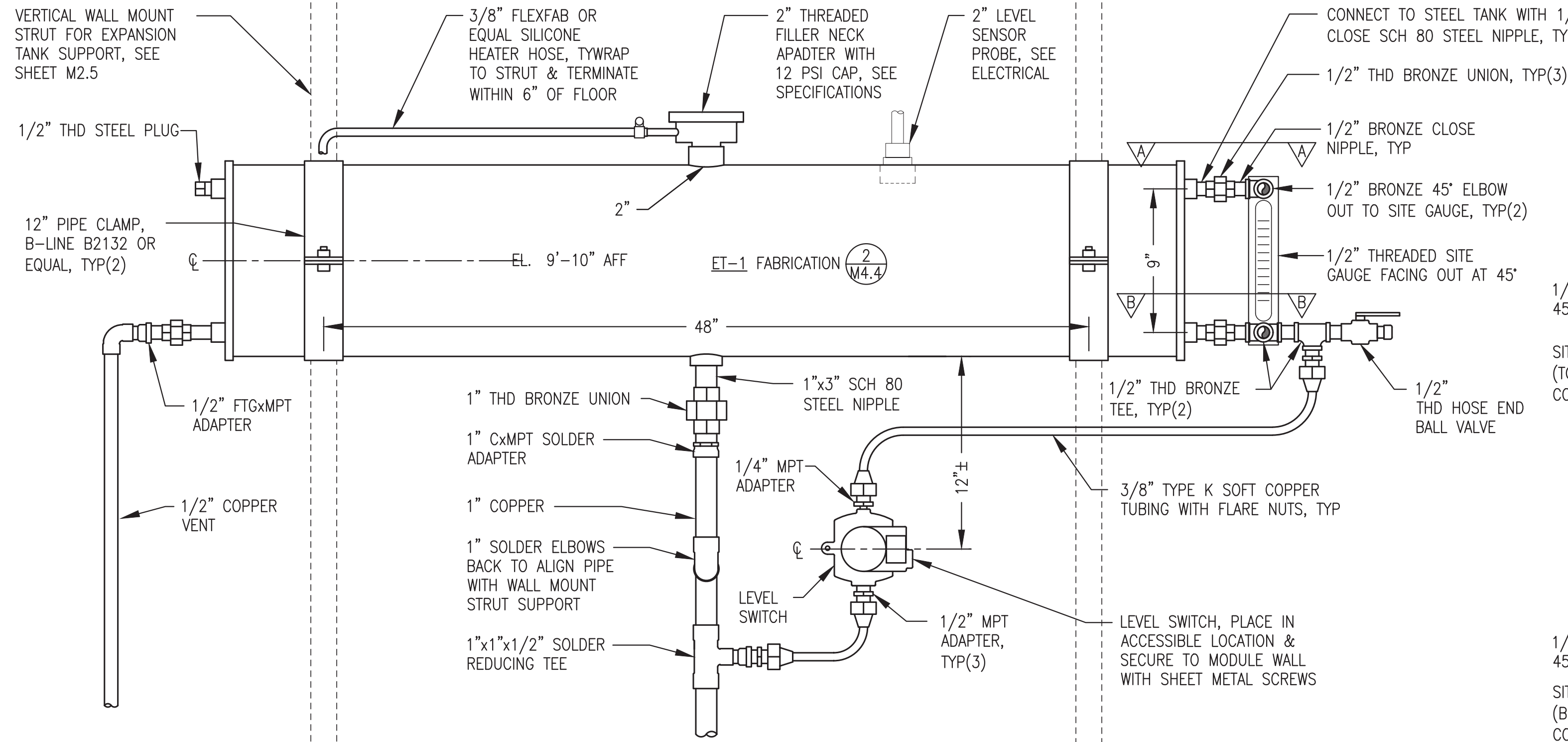

**1** 24 GAL EXPANSION TANK ET-1 INSTALLATION  
M4.3 NO SCALE

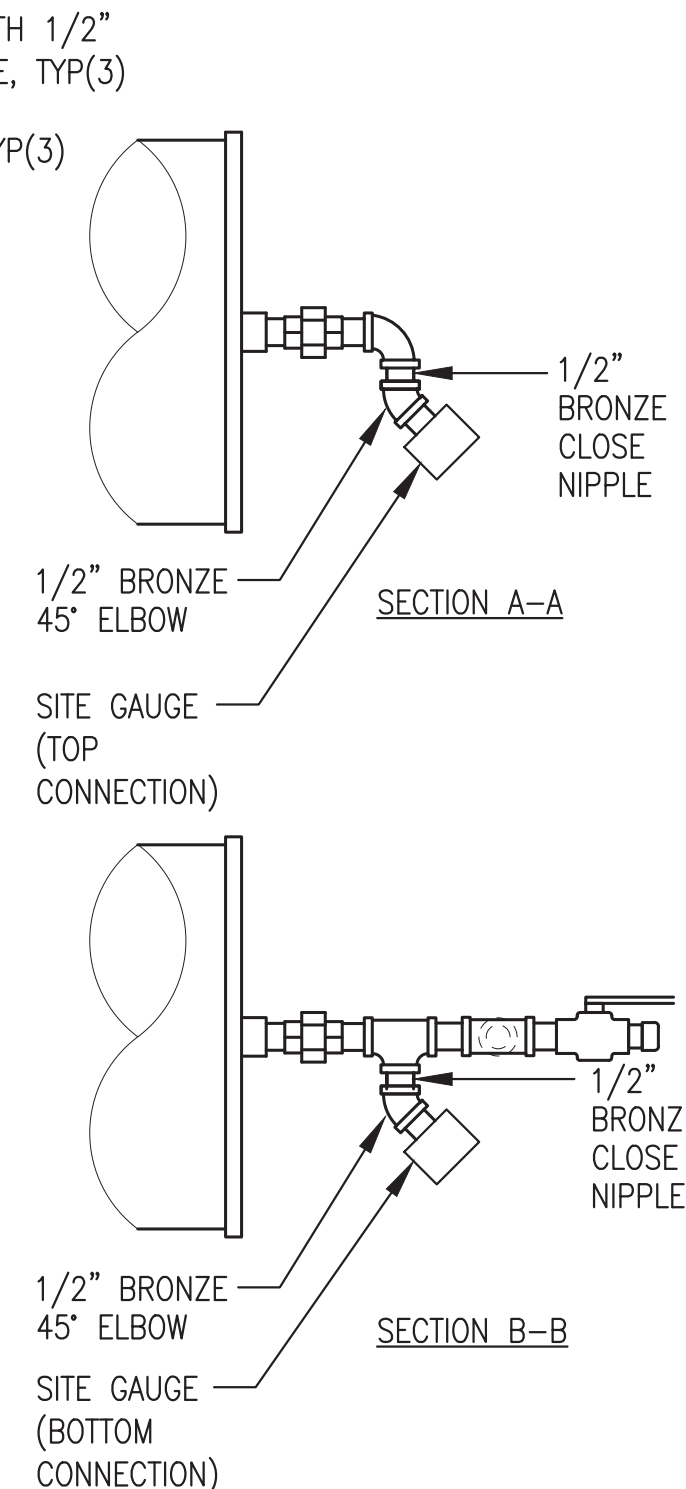

**2** TYP INSTRUMENT/DRAIN INSTALLATION IN STEEL PIPE  
M4.3 NO SCALE

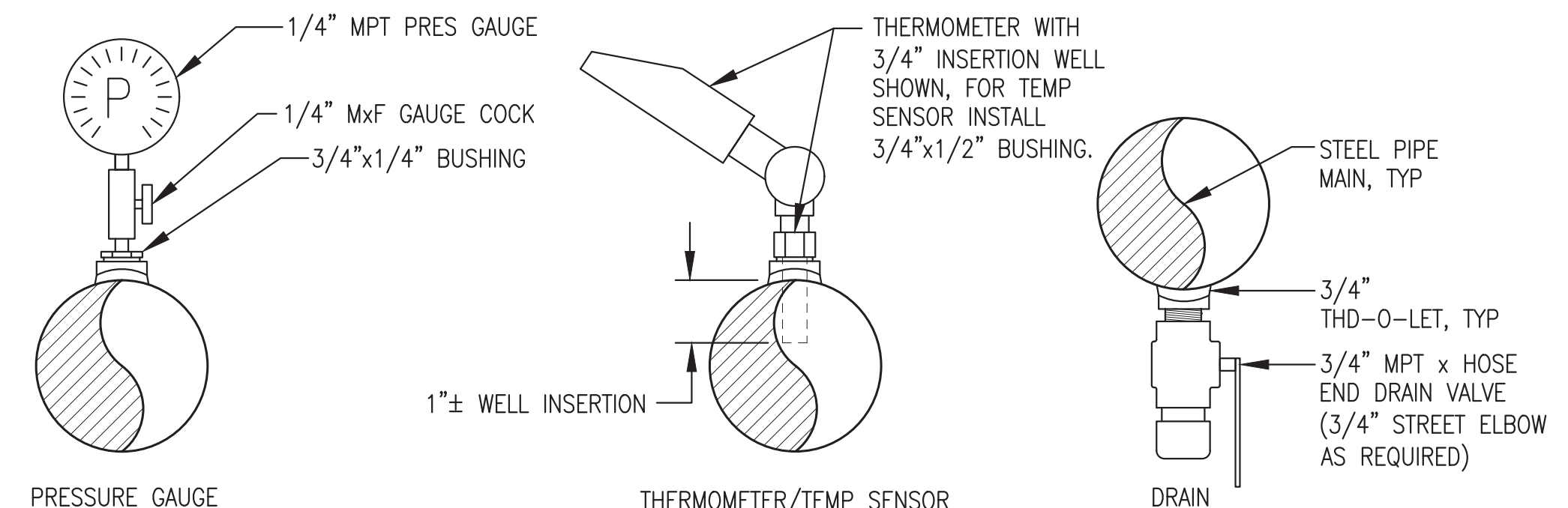

**3** TYP INSTRUMENT/DRAIN INSTALLATION IN COPPER TUBE  
M4.3 NO SCALE

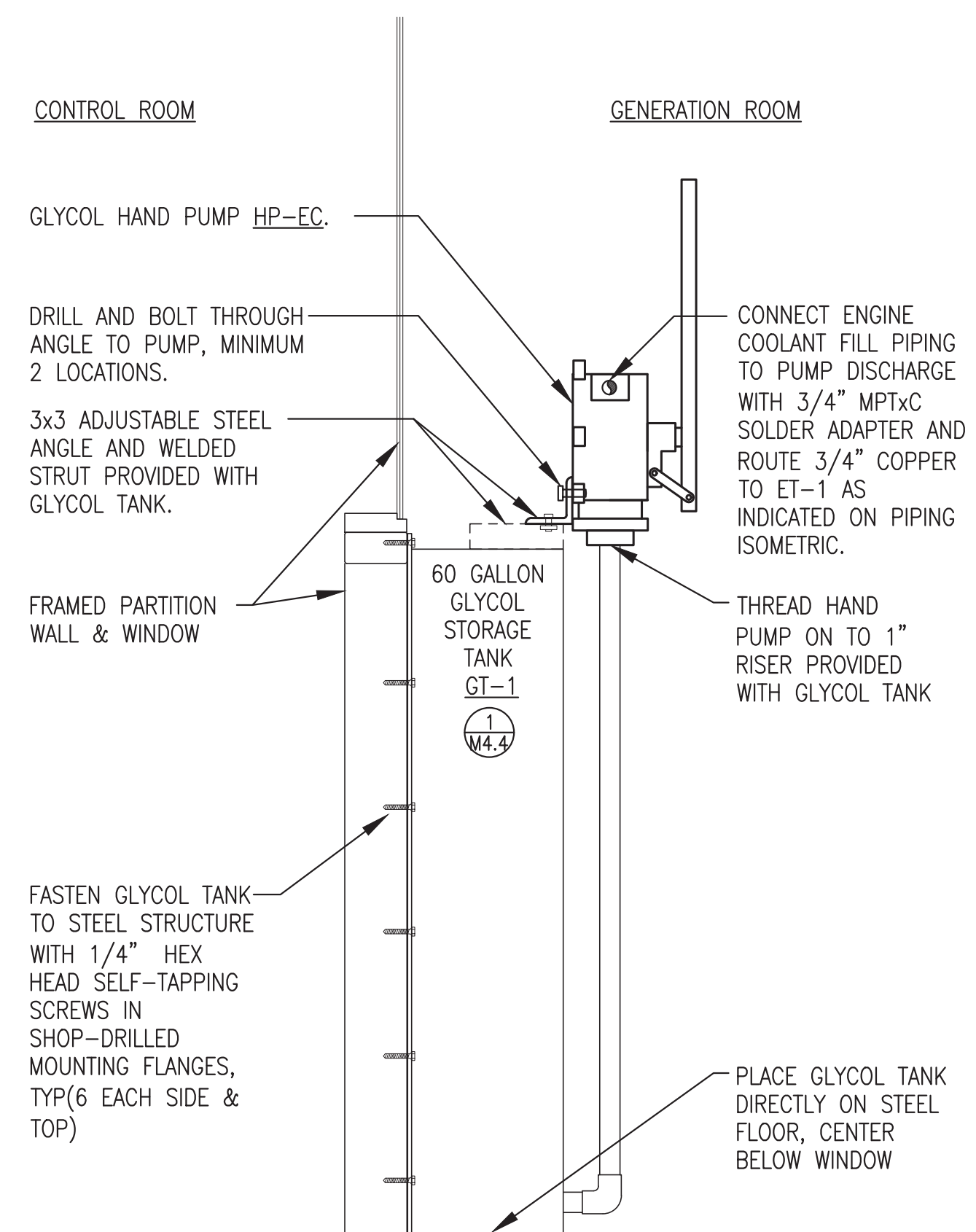

**4** GLYCOL STORAGE TANK & HAND PUMP HP-EC INSTALLATION DETAIL  
M4.3 NO SCALE

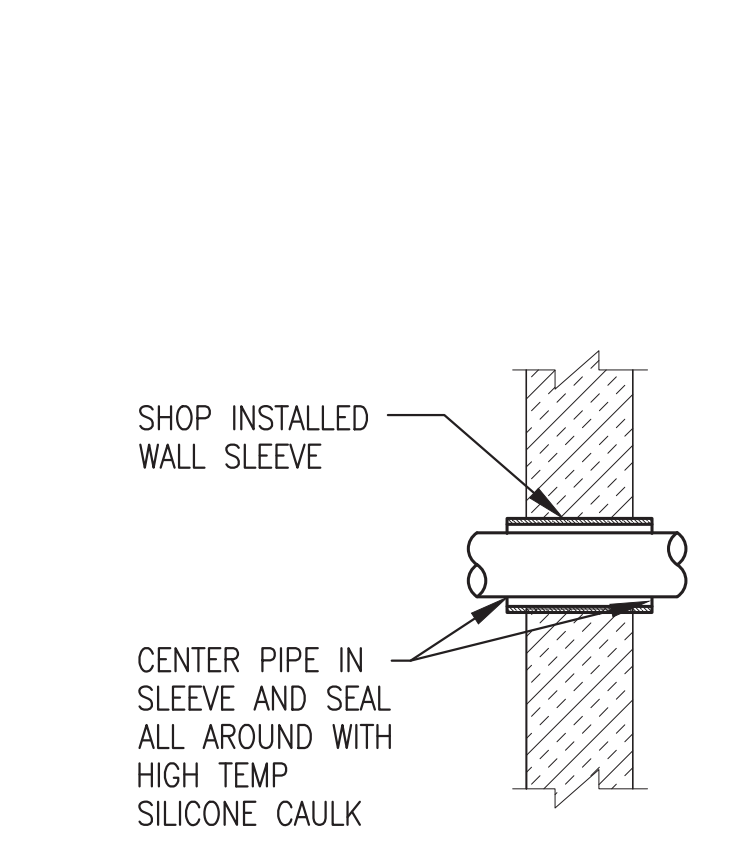

**5** COOLANT PIPING WALL PENETRATION  
M4.3 NO SCALE

**SHOP/ON-SITE NOTES:**  
1) SEAL OPENINGS AS PART OF ON-SITE WORK.

**GENERAL NOTES:**  
1) THIS DETAIL FOR COOLANT PIPING WITH SHOP INSTALLED WALL SLEEVES.  
2) FOR ALL PIPE/CONDUIT LESS THAN 2" O.D. AND WITHOUT A SHOP INSTALLED WALL SLEEVE, HOLE SAW OPENING APPROXIMATELY 1/4" LARGER THAN PIPE O.D. THROUGH WALL & SEAL ALL AROUND WITH POLYURETHANE CAULKING.

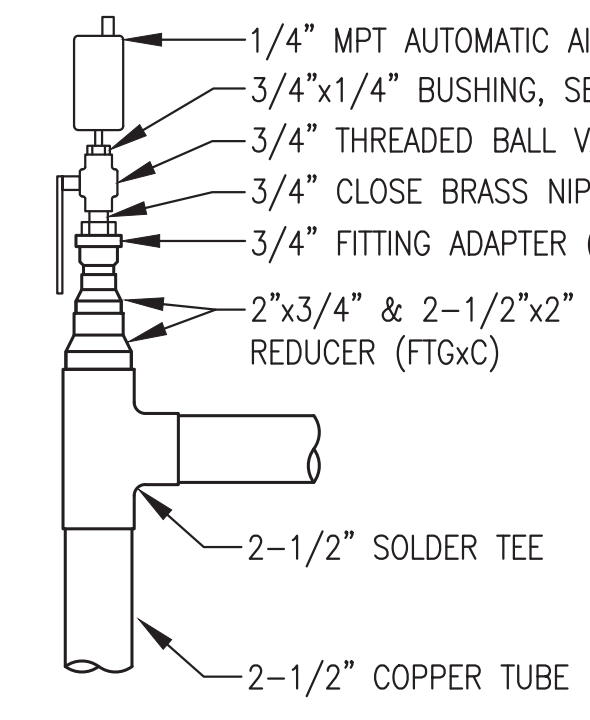

**6** TYPICAL AIR VENT INSTALLATION IN COPPER  
M4.3 NO SCALE

**NOTES:**  
1) ON INITIAL STARTUP INSTALL HOSE ADAPTER IN PLACE OF BUSHING & USE HOSE TO FLUSH & BLEED.  
2) AFTER BLEEDING SYSTEM OF AIR INSTALL BUSHING & AIR VENT & CLOSE BALL VALVE.

ALL WORK ON THIS SHEET WAS PERFORMED AS PART OF THE PRIOR MODULE ASSEMBLY CONTRACT AND IS SHOWN HERE FOR REFERENCE ONLY.

ISSUED FOR CONSTRUCTION  
JULY 2022



ALASKA ENERGY AUTHORITY	
PROJECT: NAPASKIAK POWER SYSTEM UPGRADE	
TITLE: ENGINE COOLANT & HEAT RECOVERY PIPING DETAILS	
DRAWN BY: JTD	SCALE: AS NOTED
DESIGNED BY: BCG	DATE: 7/29/22
FILE NAME: NAPS PP M2-7	SHEET: M4.3
PROJECT NUMBER:	
P.O. 111405, Anchorage, AK 99511 (907)349-0100	

**GLYCOL TANK GENERAL NOTES:**

1. FABRICATE SINGLE WALL 60 GALLON NOMINAL CAPACITY GLYCOL TANK.
2. FABRICATE FROM ASTM A-36 STEEL PLATE, 10 GAUGE MINIMUM EXCEPT FOR TOP 3/16" MINIMUM. ALL TANK SEAM JOINTS TO BE FULL CONTINUOUS WELDS.
3. PROVIDE WITH ALL OPENINGS AND ATTACHMENTS INDICATED. SEAL WELD ALL TANK ATTACHMENTS.
4. ALL FPT OPENINGS TO BE FORGED STEEL HALF COUPLINGS.
5. PRESSURE TEST COMPLETED ASSEMBLY TO 5 PSIG MAXIMUM USING SOAPY WATER SOLUTION ON ALL WELD JOINTS.
6. UPON COMPLETION OF FABRICATION, ROUND ALL CORNERS AND SHARP EDGES. SANDBLAST TANK EXTERIOR AND ALL ATTACHMENTS IN ACCORDANCE WITH SSPC-SP-6. PRIME AND COVER WITH TWO COATS OF EPOXY, PPG AMERLOC 2 VOC OR APPROVED EQUAL, COLOR ANSI 61 GRAY.
7. UPON COMPLETION FLUSH INTERIOR OF TANK TO REMOVE ALL DIRT AND DEBRIS AND AIR DRY INTERIOR. INSTALL 2" SCREENED VENT ON 2" FPT FILL CONNECTION WITH 2" CLOSE NIPPLE FOR SHIPPING. SEAL ALL OTHER OPENINGS WITH PLASTIC OR STEEL PLUGS..

**GLYCOL TANK SPECIFIC NOTES:**

- 1) 1-1/2" FPT (TANK GAUGE)
- 2) 2" FPT (VENT) - INSTALL 2" THREADED VENT CAP
- 3) 1" SCHEDULE 80 PIPE WITH THREADED TOP CONNECTION (WITHDRAWAL)
- 4) 1" SOCKETWELD 90° ELBOW
- 5) 6" LONG STRUT, END FLUSH WITH FRONT OF TANK
- 6) 2x1/4" FLAT BAR CONTINUOUS THREE SIDES
- 7) 3/8" HOLE AT 8" O.C. ALL AROUND
- 8) L3x3x1/4"x6" LONG FOR FUTURE CONNECTION TO HAND PUMP BY OTHERS. PAINT TO MATCH TANK AND FASTEN TO STRUTS WITH 1/2" BOLTS & STRUT NUTS.

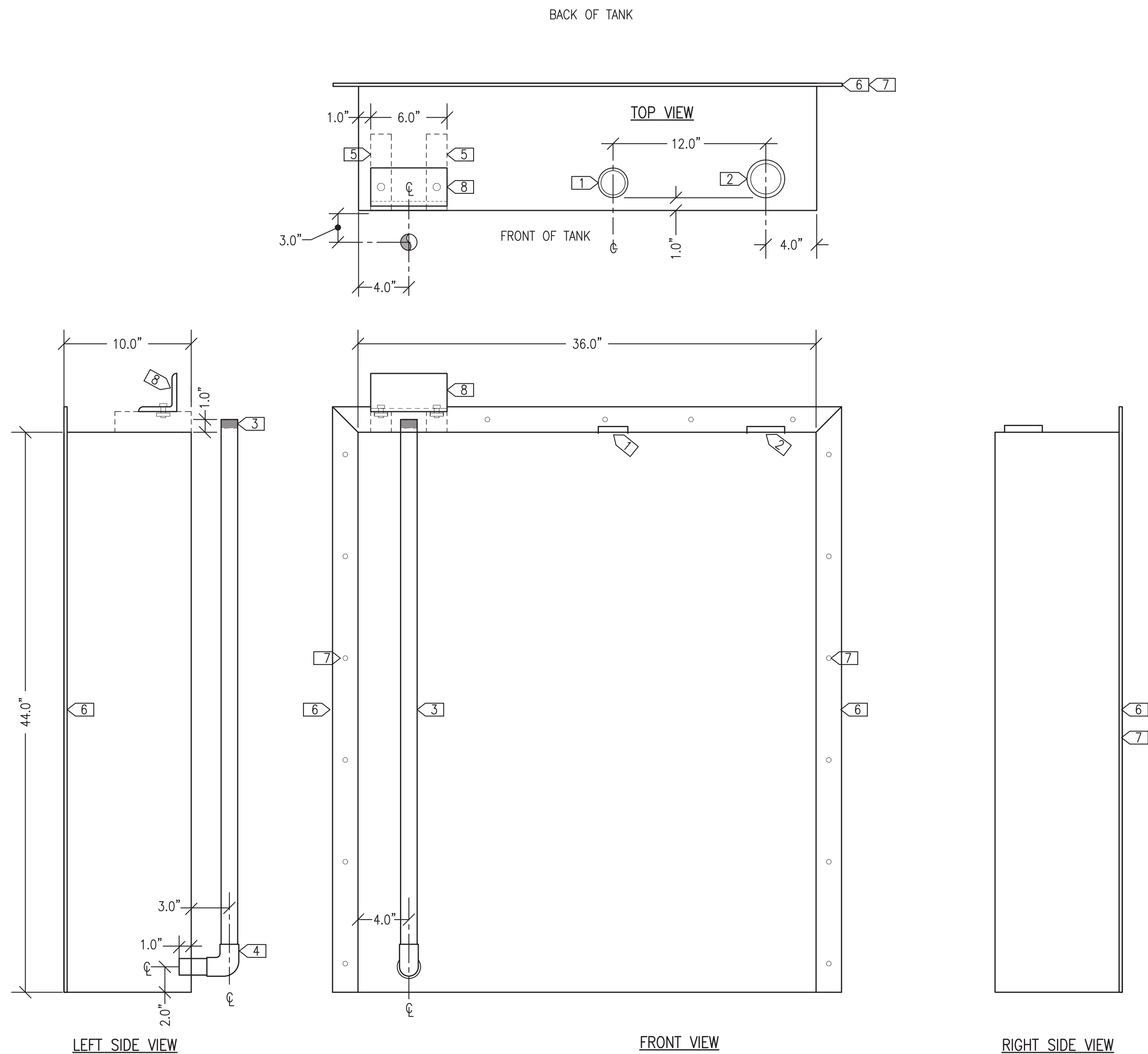

1 60 GALLON GLYCOL STORAGE TANK GT-1  
M4.4 1"=6"

**EXPANSION TANK GENERAL NOTES:**

- 1) FABRICATE SINGLE WALL 30 GALLON NOMINAL CAPACITY GLYCOL EXPANSION TANK.
- 2) FABRICATE SHELL FROM MINIMUM 10 GAUGE ASTM A-36 PLATE STEEL ROLLED AND WELDED OR SCHEDULE 5 LIGHTWALL ASTM A53 STEEL PIPE. FABRICATE HEADS FROM 3/16" THICK ASTM A-36 PLATE STEEL. MAKE ALL JOINTS WITH CONTINUOUS FULL-PENETRATION WELDS.
- 3) PROVIDE WITH ALL OPENINGS INDICATED USING MINIMUM 3000# FORGED STEEL PIPE HALF COUPLINGS IN ACCORDANCE WITH U.L 142 FIGURE 7.1 #2.
- 4) PRESSURE TEST COMPLETED ASSEMBLY TO 15 PSIG MINIMUM.
- 5) UPON COMPLETION OF FABRICATION, ROUND ALL CORNERS AND SHARP EDGES. SANDBLAST TANK EXTERIOR AND ALL ATTACHMENTS IN ACCORDANCE WITH SSPC-SP-6. PAINT WITH TWO COATS EPOXY, PPG AMERLOC 2 VOC OR APPROVED EQUAL, COLOR ANSI 61 GRAY.
- 6) UPON COMPLETION FLUSH INTERIOR OF TANK TO REMOVE ALL DIRT AND DEBRIS, AIR DRY INTERIOR, AND SEAL ALL TANK OPENINGS WITH PLASTIC PLUGS.

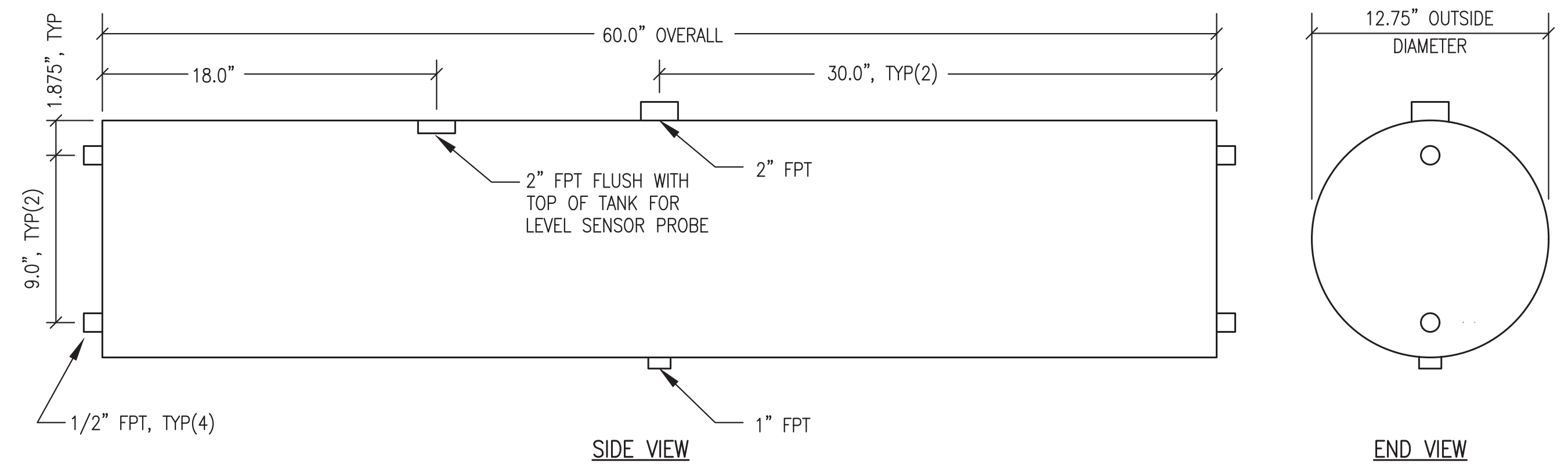

2 30 GALLON GLYCOL EXPANSION TANK ET-1  
M4.4 1"=6"

ALL WORK ON THIS SHEET WAS PERFORMED AS PART OF THE PRIOR MODULE ASSEMBLY CONTRACT AND IS SHOWN HERE FOR REFERENCE ONLY.

ISSUED FOR CONSTRUCTION  
JULY 2022

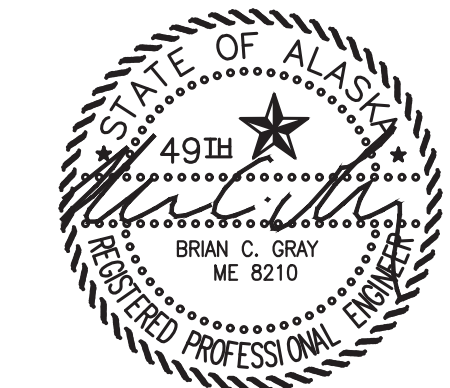

ALASKA ENERGY AUTHORITY		
PROJECT: NAPASKIAK POWER SYSTEM UPGRADE		
TITLE: GLYCOL STORAGE & EXPANSION TANKS FABRICATION		
DESIGNED BY: BCG	SCALE: AS NOTED	DATE: 7/29/22
FILE NAME: NAPS PP M2-7	SHEET: M4.4	
PROJECT NUMBER:		
P.O. 111405, Anchorage, AK 99511 (907)349-0100		

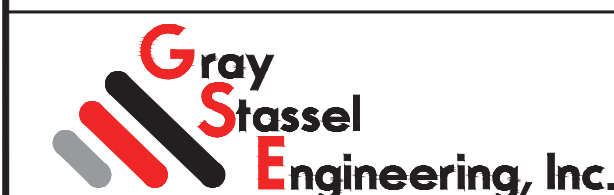

DRAWN BY: JTD  
DESIGNED BY: BCG  
FILE NAME: NAPS PP M2-7  
PROJECT NUMBER:



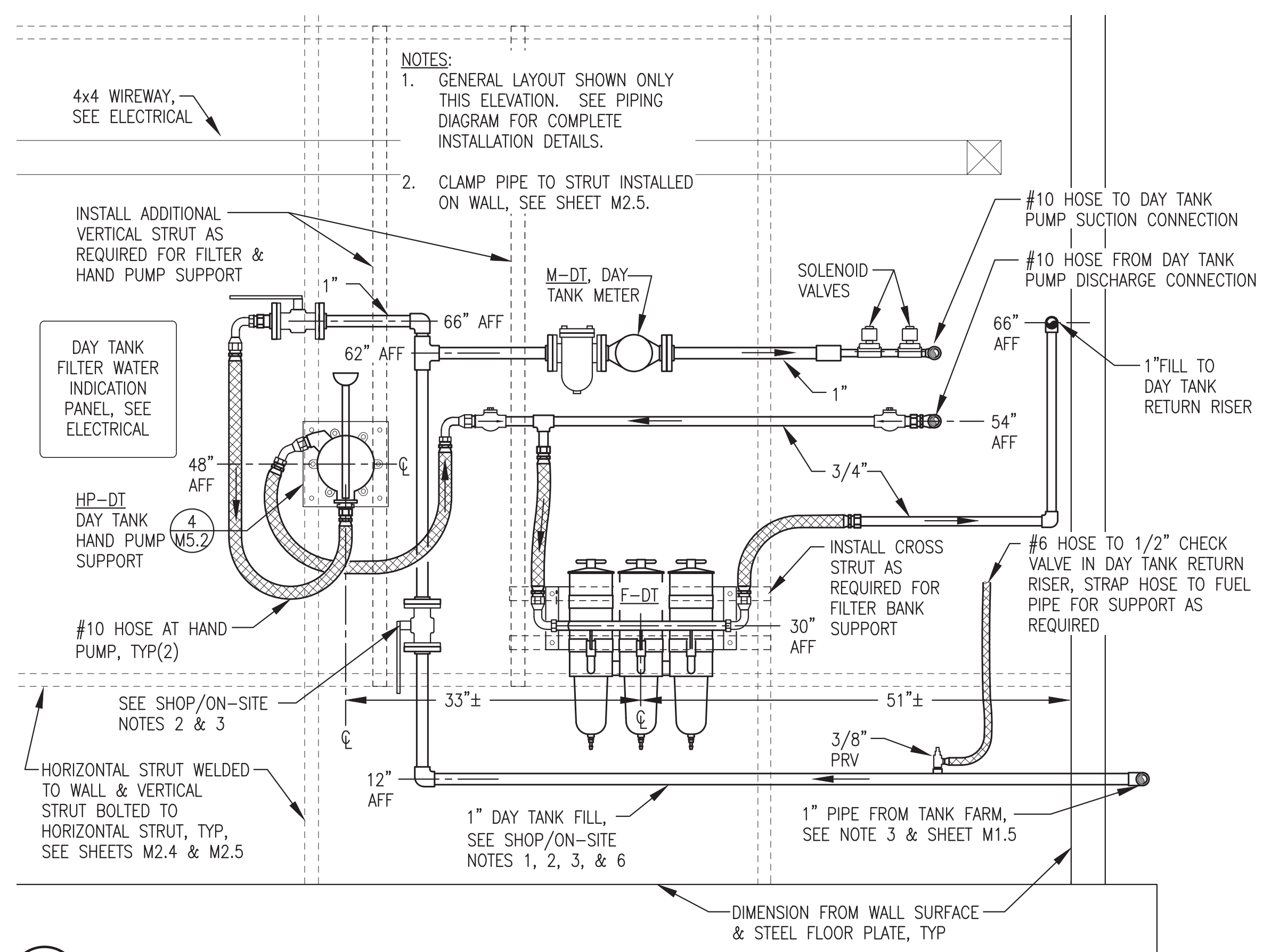

**1** DIESEL FUEL FRONT WALL ELEVATION  
 M5.2 1"=1"

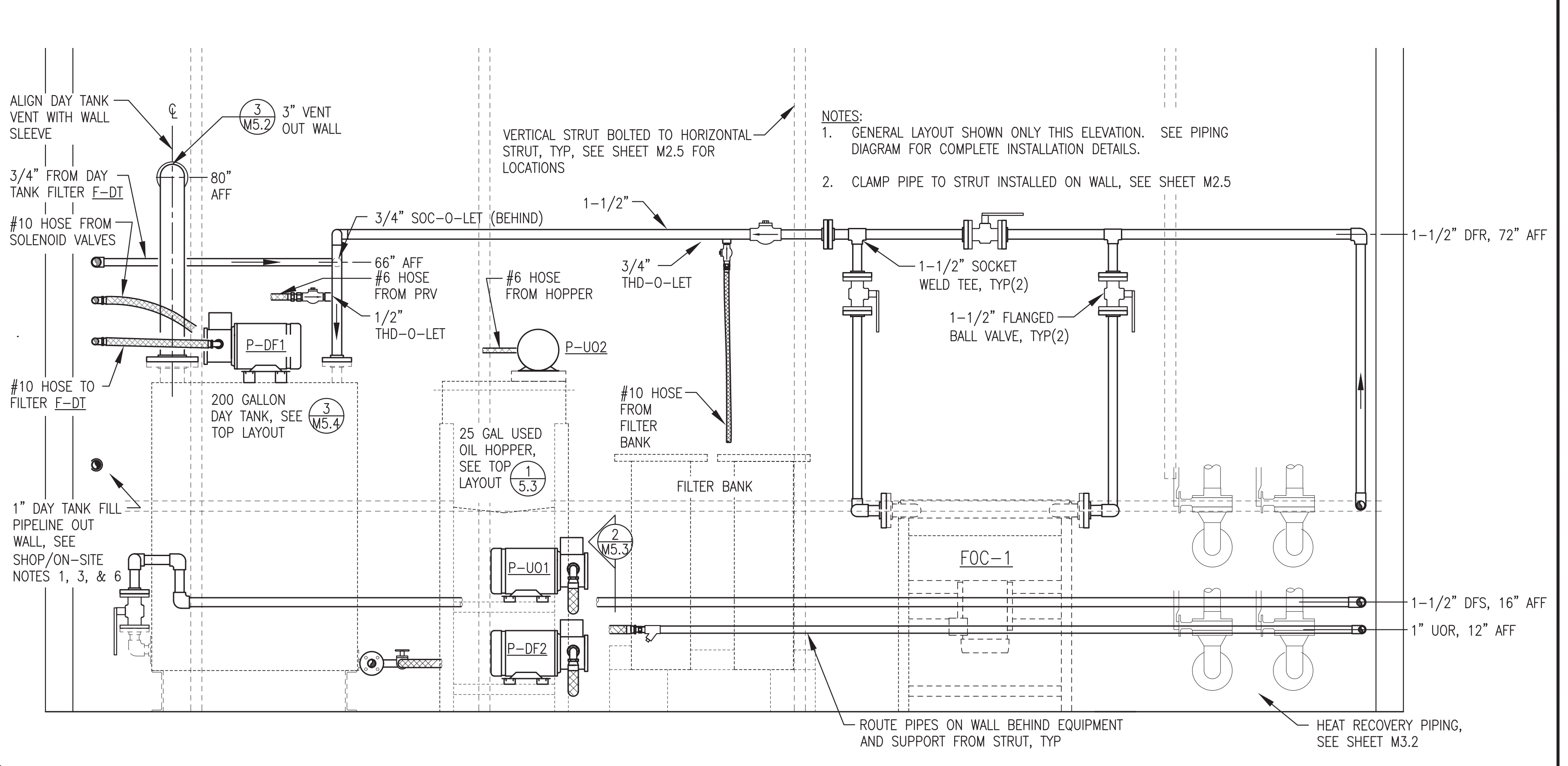

**2** DIESEL FUEL & USED OIL END WALL ELEVATION  
 M5.2 1"=1"

**FUEL SHOP/ON-SITE NOTES:**

- DURING SHOP FABRICATION HOLE SAW 1-1/2" Ø OPENING FOR DAY TANK FILL PIPE, STUB PIPE 12" MIN BEYOND WALL, & TERMINATE WITH 1" MALE THREAD FOR TESTING.
- UPON COMPLETION OF TESTING CLOSE VALVE, DRAIN PIPE, DISCONNECT FLANGE FROM VALVE THEN SLIDE PIPE OVER & SECURE FOR SHIPPING. SEAL WALL OPENING.
- AS PART OF ON-SITE INSTALLATION REINSTALL FILL PIPE THEN CUT THREADS OFF EXTERIOR END & INSTALL SOCKET WELD ELBOW.
- DURING SHOP FABRICATION INSTALL TEMPORARY VENT PIPE OUT WALL. UPON COMPLETION OF TESTING REMOVE TEMPORARY PIPE & SEAL WALL OPENING FOR SHIPPING.
- AS PART OF ON-SITE INSTALLATION INSTALL 3" GALVANIZED THREADED VENT PIPE OUT WALL & UP TO VENT CAP. SEE DETAIL 3/M5.2. AT CONTRACTOR'S OPTION VENT PIPE MAY HAVE WELD JOINTS & CARBON STEEL WELD ELBOWS. AFTER FABRICATION CLEAN & COAT WITH COLD GALVANIZING COMPOUND.
- UPON FINAL ON-SITE ASSEMBLY SEAL 1" FILL PIPE TO EXTERIOR WALL & 3" VENT PIPE TO WALL SLEEVE WITH POLYURETHANE CAULKING ALL AROUND.

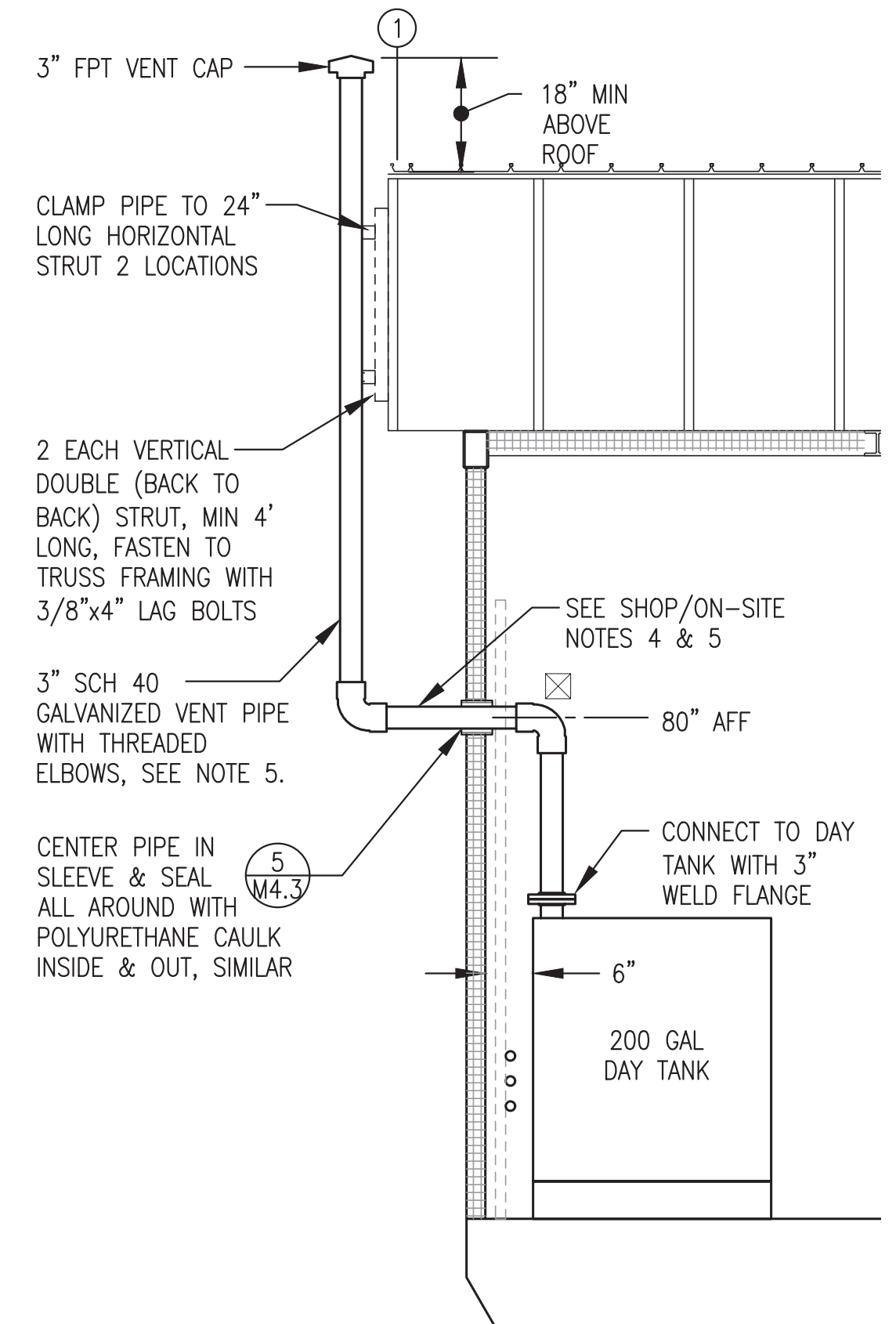

**3** DAY TANK VENT INSTALLATION  
 M5.2 1/2"=1'-0"

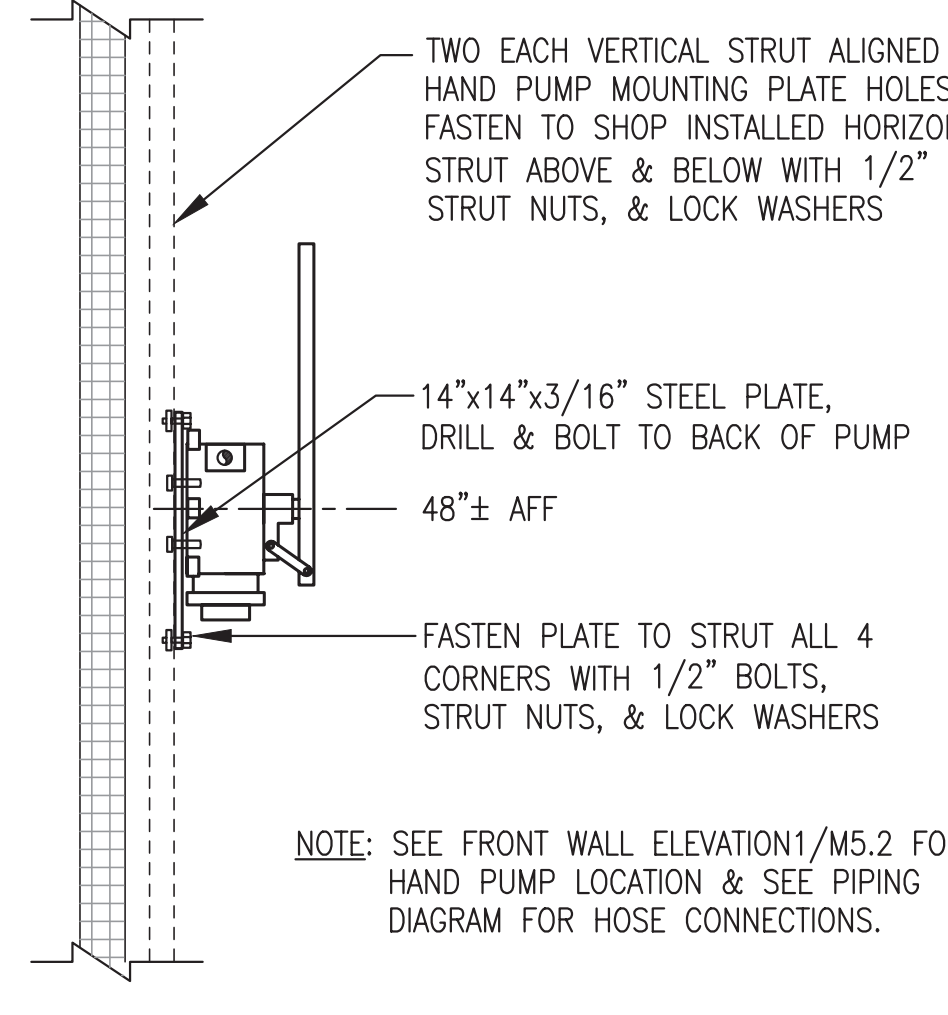

**4** DAY TANK HAND PUMP HP-DT WALL SUPPORT  
 M5.2 NO SCALE

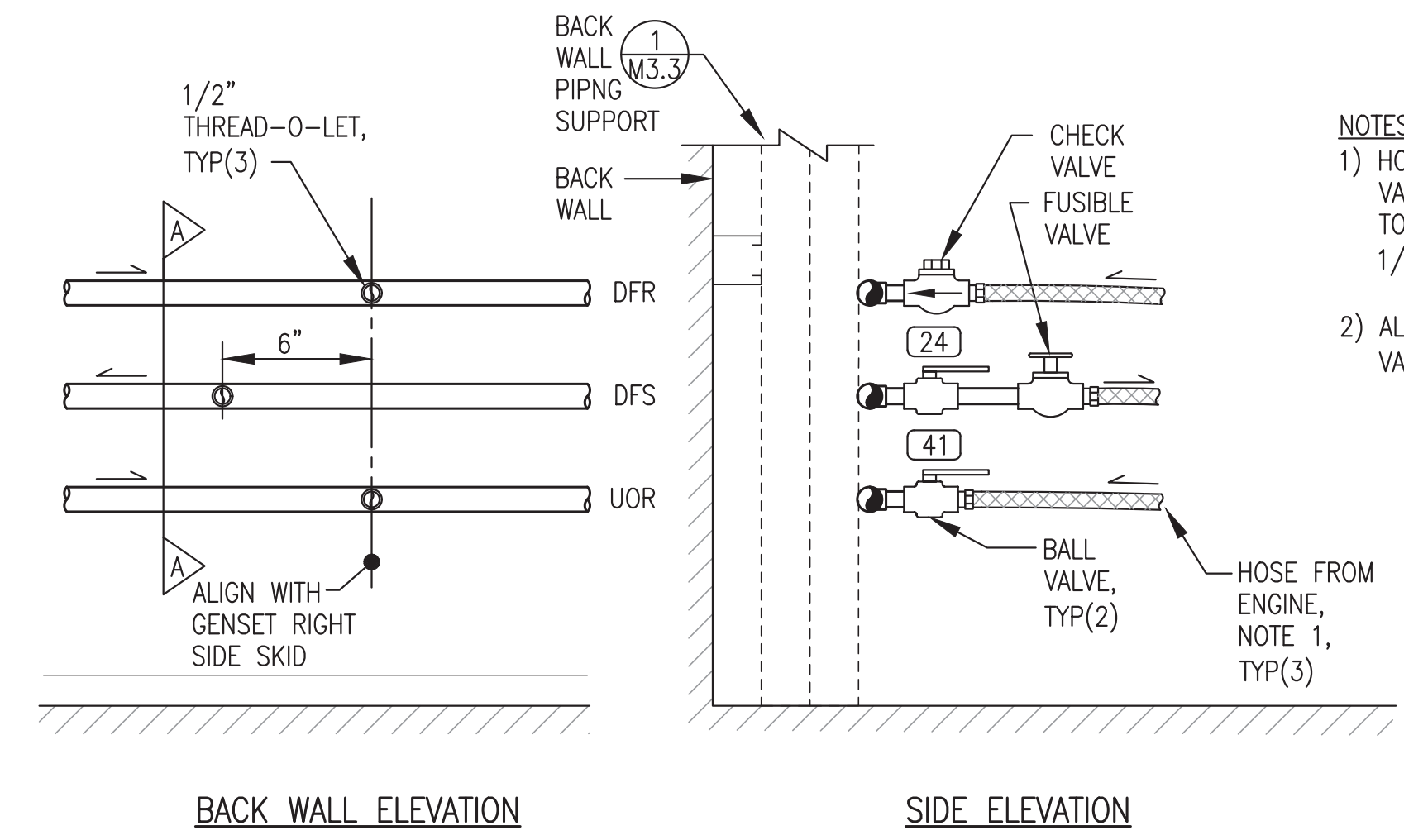

**5** ENGINE FUEL PIPING CONNECTION  
 M5.2 NO SCALE

- NOTES:**  
 1) HOSES PROVIDED WITH ENGINE, SIZE VARIES PER ENGINE & PRODUCT. CUT TO LENGTH & INSTALL JIC SWIVELS & 1/2" MPT ADAPTERS.  
 2) ALL PIPING & NIPPLES SCH 80. ALL VALVES 1/2" SIZE, THREADED BODY.

**ALL WORK ON THIS SHEET WAS PERFORMED AS PART OF THE PRIOR MODULE ASSEMBLY CONTRACT EXCEPT AS SPECIFICALLY INDICATED IN THE SHOP/ON SITE NOTES.**

ISSUED FOR CONSTRUCTION  
 JULY 2022

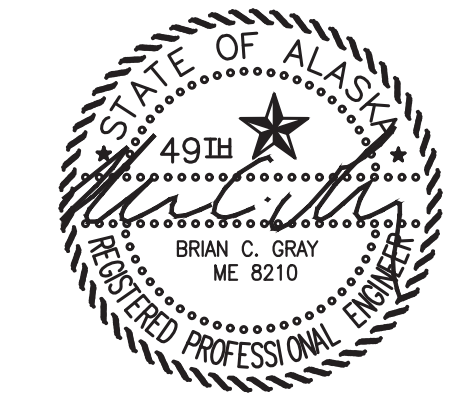

PROJECT: NAPASKIAK POWER SYSTEM UPGRADE	
TITLE: DIESEL FUEL & USED OIL PIPING ELEVATIONS & DETAILS	
DRAWN BY: JTD	SCALE: AS NOTED
DESIGNED BY: BCG	DATE: 7/29/22
FILE NAME: NAPS PP M2-7	SHEET: <b>M5.2</b>
PROJECT NUMBER: P.O. 111405, Anchorage, AK 99511 (907)349-0100	

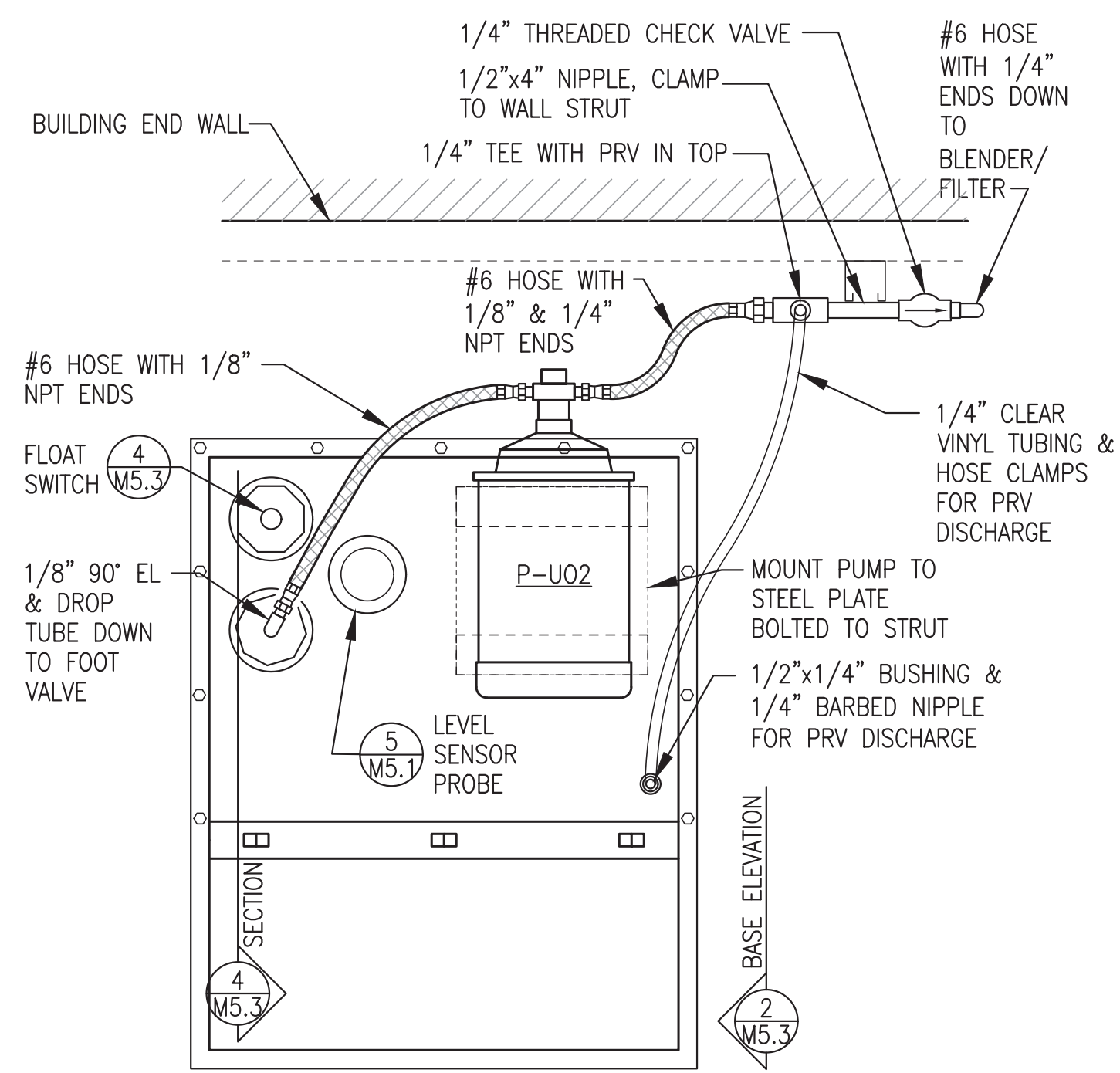

1 TOP OF HOPPER - PLAN VIEW  
M5.3 NO SCALE

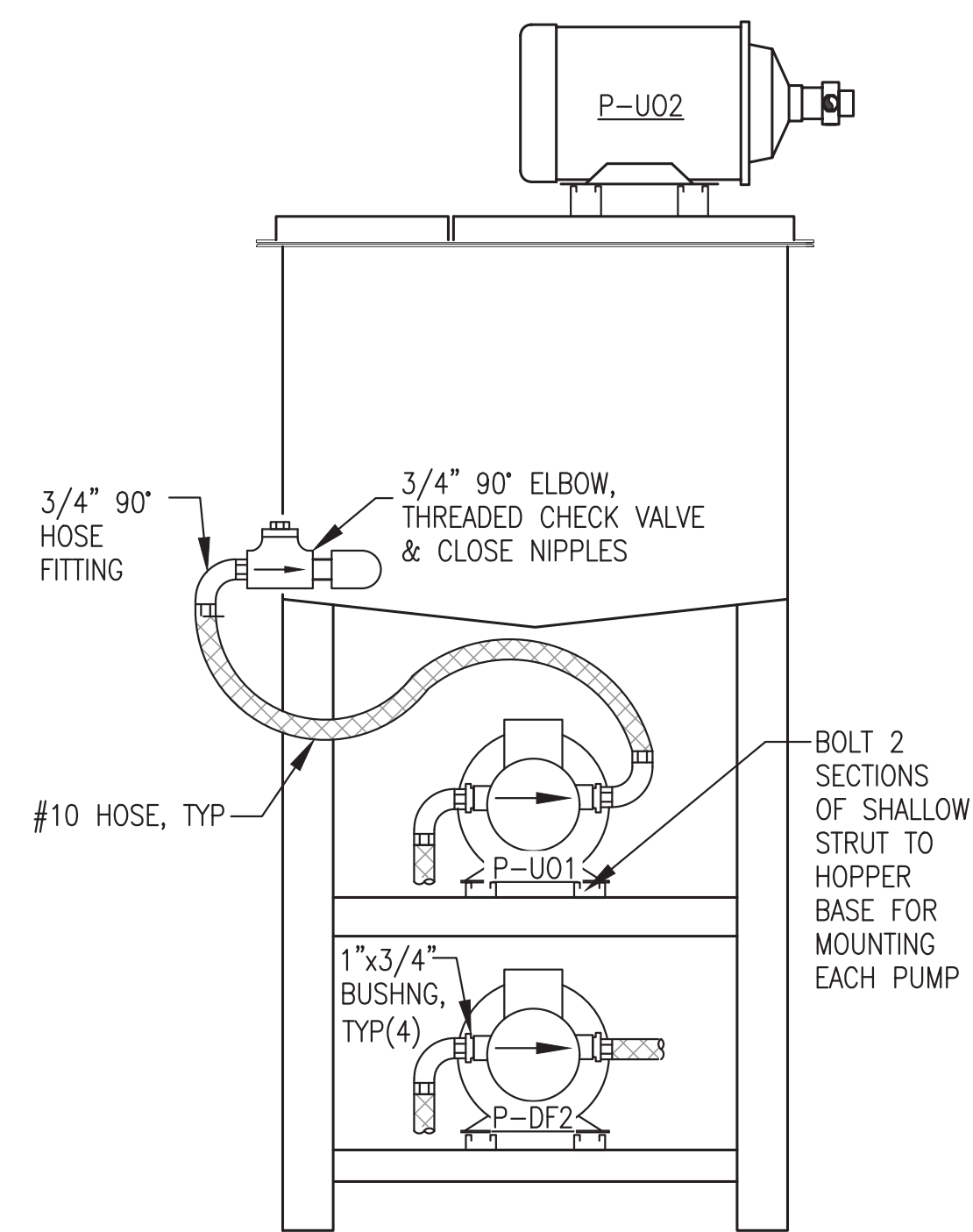

2 HOPPER BASE ELEVATION  
M5.3 NO SCALE

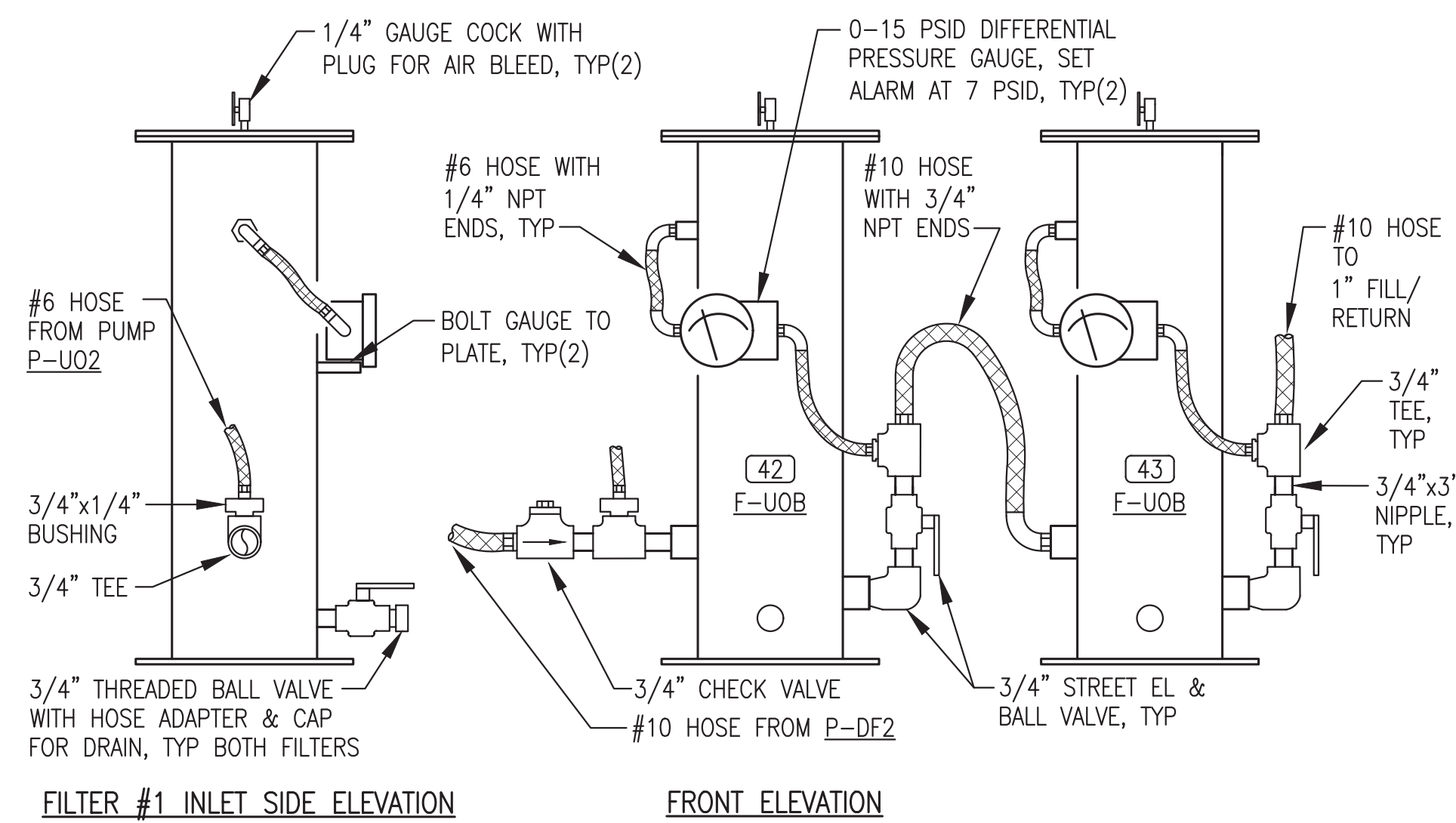

3 FILTER BANK ELEVATIONS  
M5.3 NO SCALE

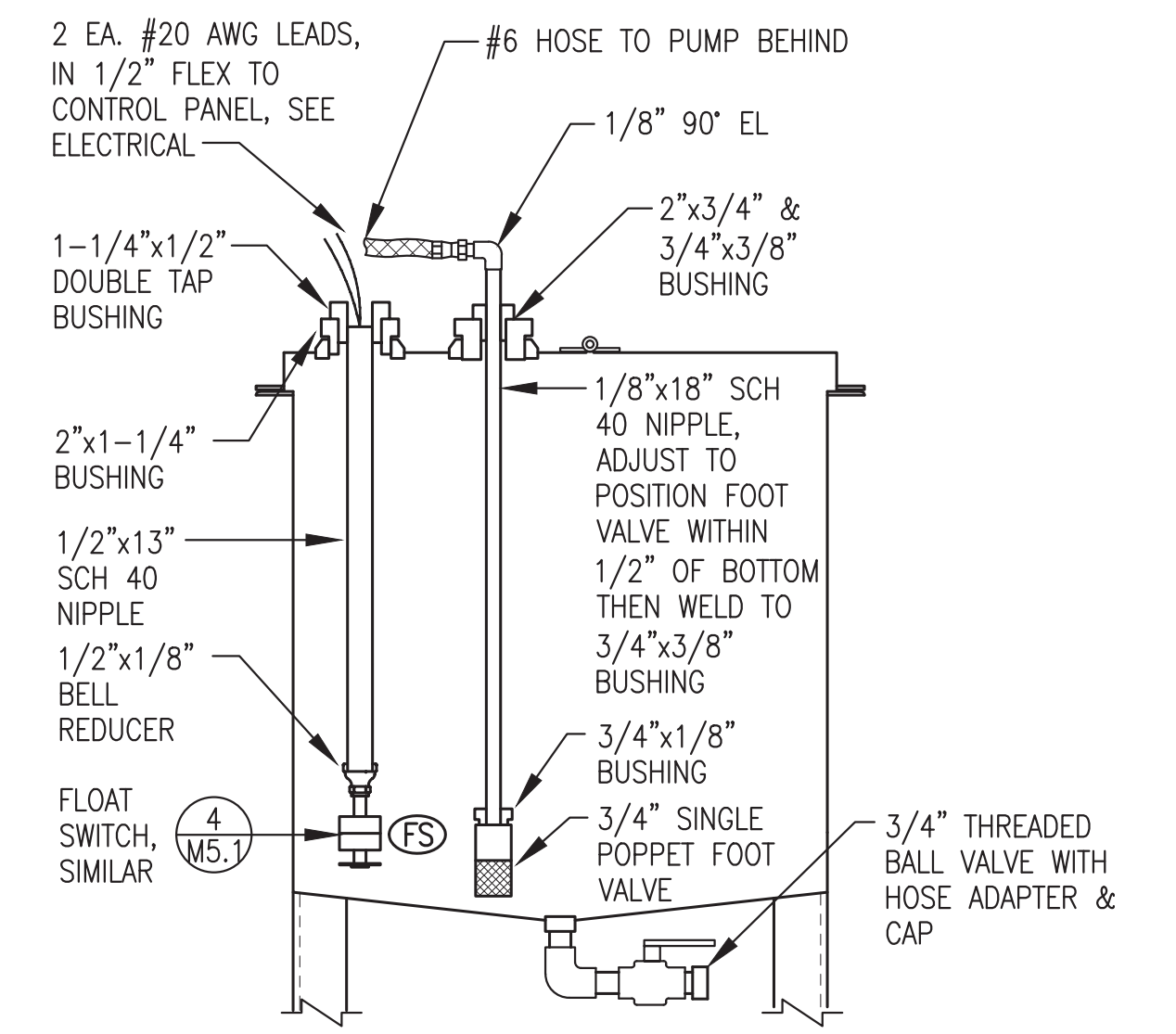

4 SECTION THROUGH HOPPER  
M5.3 NO SCALE

ALL WORK ON THIS SHEET WAS PERFORMED AS PART OF THE PRIOR MODULE ASSEMBLY CONTRACT AND IS SHOWN HERE FOR REFERENCE ONLY.

ISSUED FOR CONSTRUCTION  
JULY 2022

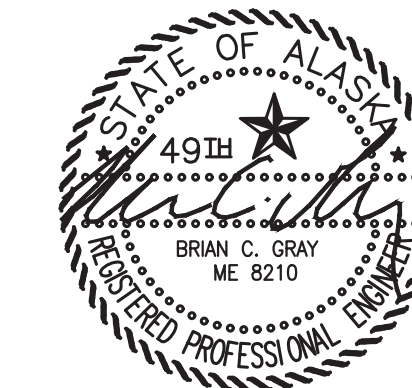

PROJECT: NAPASKIAK POWER SYSTEM UPGRADE		
TITLE: USED OIL HOPPER & BLENDER INSTALLATION DETAILS		
	DRAWN BY: JTD DESIGNED BY: BCG FILE NAME: NAPS PP M2-7 PROJECT NUMBER:	SCALE: AS NOTED DATE: 7/29/22 SHEET: <b>M5.3</b>
P.O. 111405, Anchorage, AK 99511 (907)349-0100		

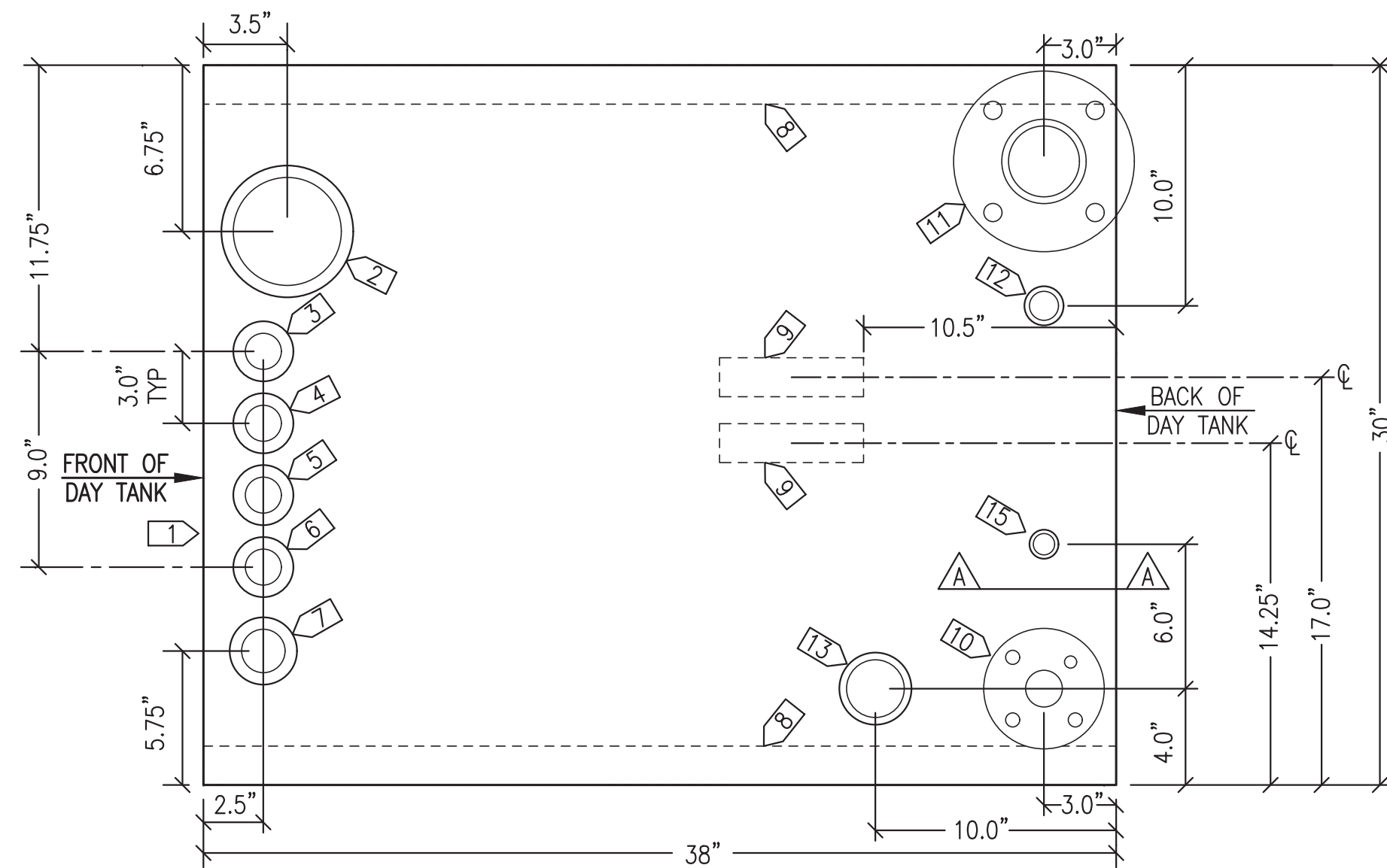

TOP VIEW

**DAY TANK SPECIFICATIONS:**

- 1) FABRICATE SINGLE WALL 200 GALLON NOMINAL CAPACITY DAY TANK. FABRICATE IN ACCORDANCE WITH UL 142.
- 2) FABRICATE FROM ASTM A-36 STEEL PLATE, 10 GAUGE MINIMUM EXCEPT FOR TOP 3/16" MINIMUM. ALL TANK SEAM JOINTS TO BE FULL CONTINUOUS WELDS IN ACCORDANCE WITH UL 142 FIGURE 6.5 - #1, #6, #7, OR #8.
- 3) PROVIDE WITH ALL OPENINGS AND ATTACHMENTS INDICATED. ALL STRUT TO BE 1-5/8"x1-5/8"x12 GA SOLID BACK PLAIN (BLACK), B-LINE B22 PLN OR EQUAL. SEAL WELD ALL TANK ATTACHMENTS.
- 4) INSTALL ALL FPT OPENINGS IN ACCORDANCE WITH UL 142 FIGURE 7.1 - #4 UNLESS INDICATED OTHERWISE. ALL DROP TUBES SCH 40 ASTM A53 STEEL PIPE WITH MPT OR FLANGED END AS INDICATED.
- 5) PRESSURE TEST COMPLETED ASSEMBLY TO 5 PSIG MAXIMUM USING SOAPY WATER SOLUTION ON ALL WELD JOINTS.
- 6) UPON COMPLETION OF FABRICATION, ROUND ALL CORNERS AND SHARP EDGES. SANDBLAST TANK EXTERIOR AND ALL ATTACHMENTS IN ACCORDANCE WITH SSPC-SP-6. PAINT WITH TWO COATS EPOXY, PPG AMERLOC 2 VOC OR APPROVED EQUAL, COLOR ANSI 61 GRAY.
- 7) LABEL ALL OPENINGS WITH 1/4" BLACK LETTERS INDICATING FUNCTION AS LISTED IN PARENTHESES IN SPECIFIC NOTES.
- 8) UPON COMPLETION FLUSH INTERIOR OF TANK TO REMOVE ALL DIRT AND DEBRIS AND AIR DRY INTERIOR. SEAL ALL MPT OPENINGS WITH THREADED STEEL CAPS. SEAL FPT TANK OPENINGS WITH THREADED STEEL PIPE PLUGS WHERE INDICATED. INSTALL 1-1/4" VENT CAP WHERE INDICATED. SEAL ALL OTHER FPT OPENINGS WITH PLASTIC OR STEEL PLUGS.

**DAY TANK SPECIFIC NOTES:**

- 1) PROVIDE 2" HIGH LETTERING: "DIESEL FUEL 200 GALLONS"
- 2) 4" FPT (MANUAL FILL) - INSTALL THREADED STEEL PLUG
- 3) 1-1/4" FPT (OVERFILL) - INSTALL VENT CAP FOR SHIPPING
- 4) 1-1/4" FPT (PUMP STOP)
- 5) 1-1/4" FPT (PUMP START)
- 6) 1-1/4" FPT (LOW ALARM)
- 7) 1-1/2" FPT (TANK GAUGE)
- 8) 38"L STRUT, ENDS FLUSH WITH TANK
- 9) 6"L STRUT
- 10) 1-1/2" SCH 40 DROP TUBE (FILL) WITH 1" 150# FLANGE
- 11) 3" 150# FLANGED VENT CONNECTION
- 12) 1" FPT (SPARE) - INSTALL THREADED STEEL PLUG
- 13) 2" FPT (TANK LEVEL PROBE)
- 14) C6x8.2, 38" LONG
- 15) 1" MPT FOR TEMPERATURE SENSING

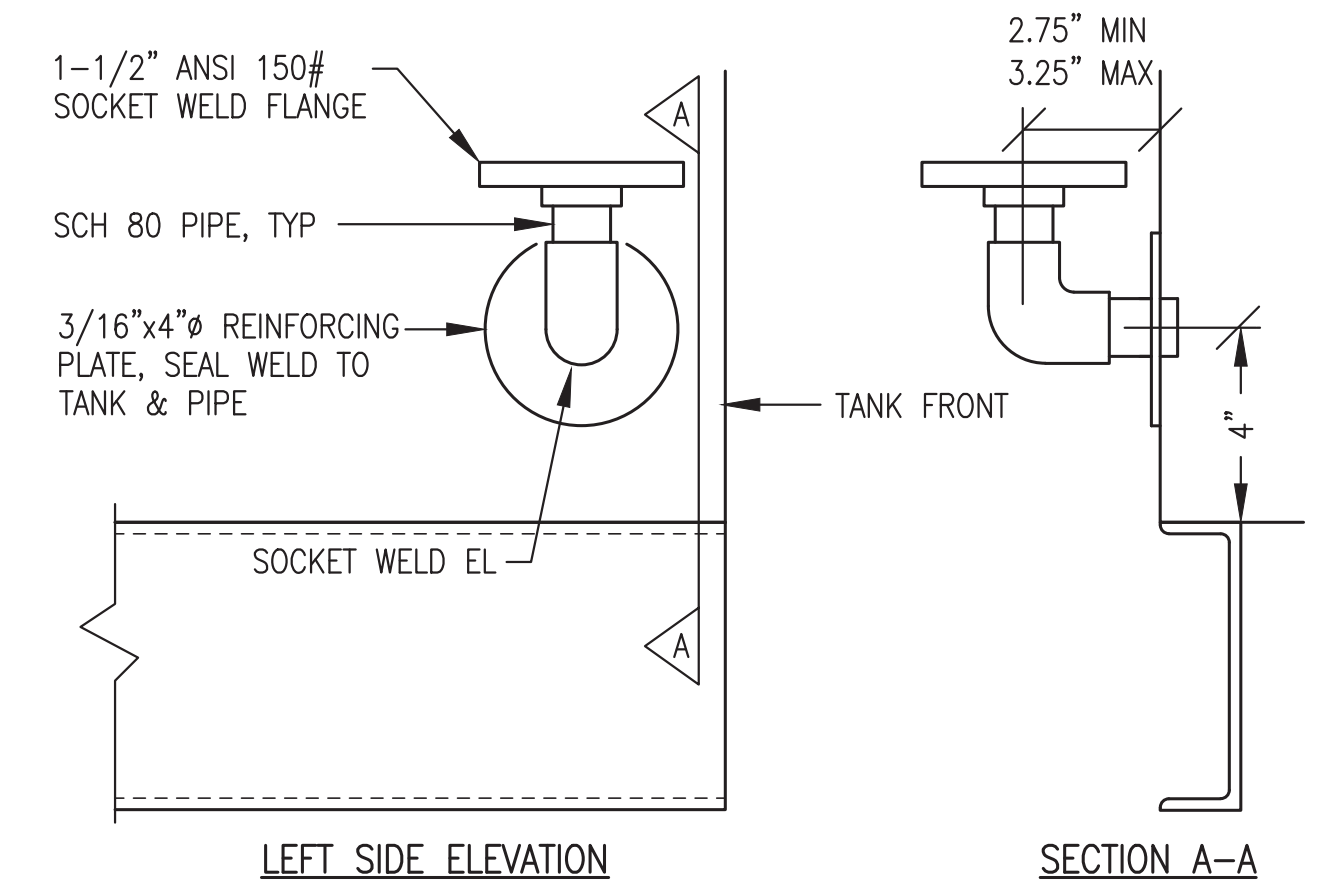

2 1-1/2" FLANGED SUPPLY CONNECTION  
M5.4 NO SCALE

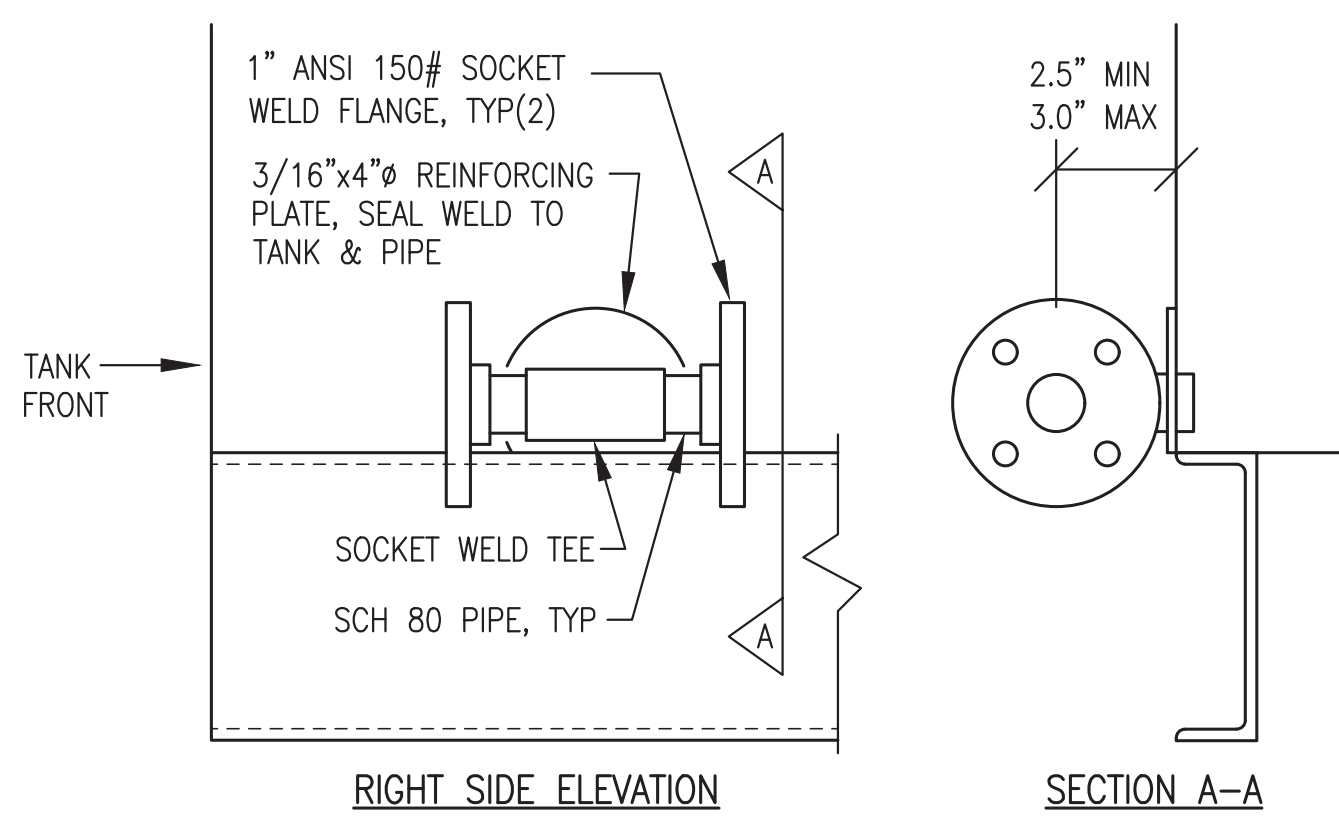

3 1" FLANGED DRAIN CONNECTION  
M5.4 NO SCALE

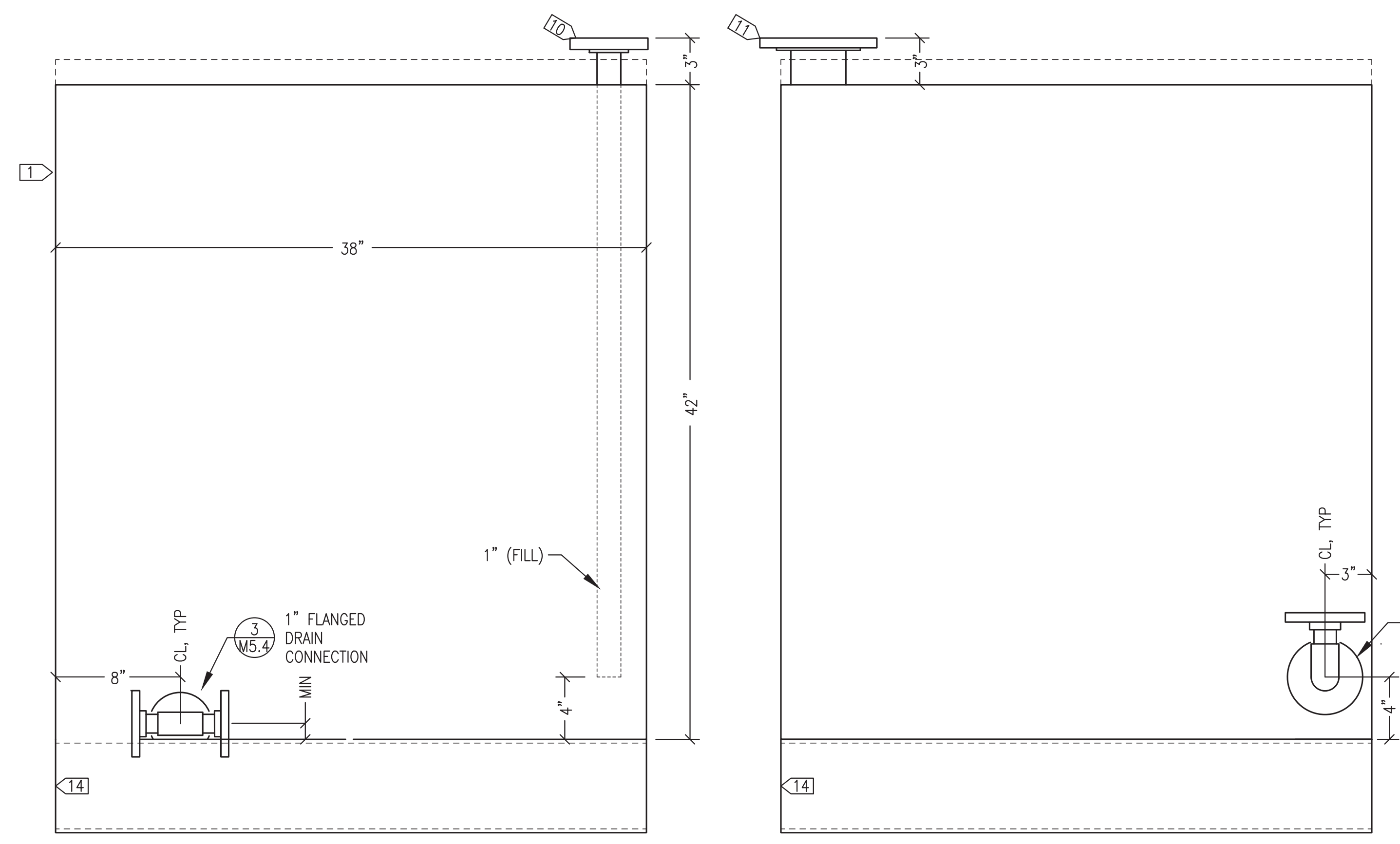

RIGHT SIDE VIEW

LEFT SIDE VIEW

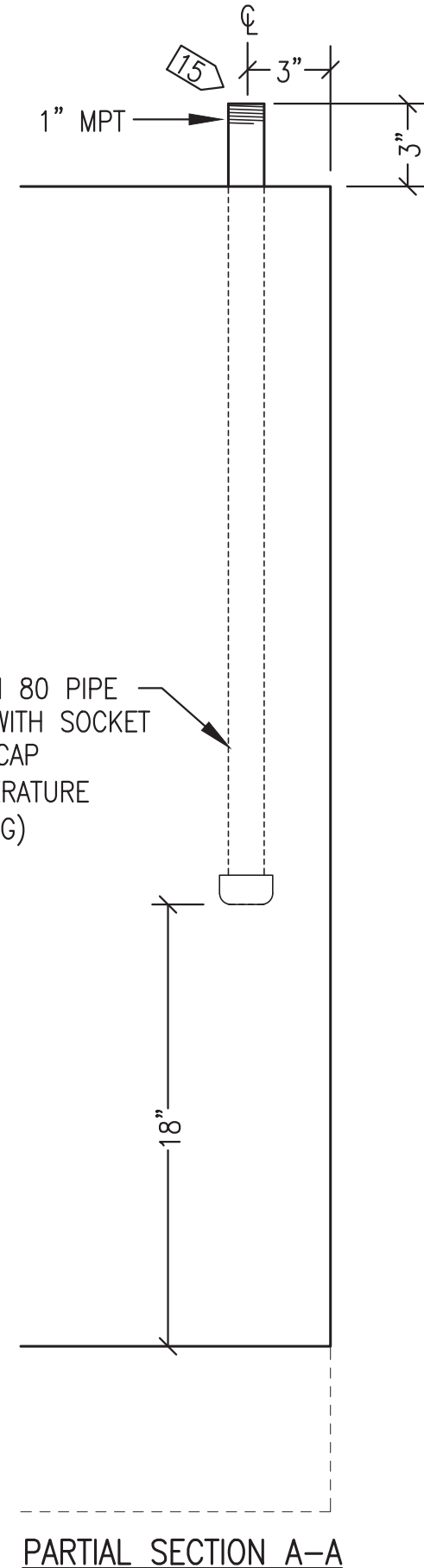

PARTIAL SECTION A-A

ALL WORK ON THIS SHEET WAS PERFORMED AS PART OF THE PRIOR MODULE ASSEMBLY CONTRACT AND IS SHOWN HERE FOR REFERENCE ONLY.

1 200 GALLON SINGLE WALL DAY TANK  
M5.4 1"=6"

ISSUED FOR CONSTRUCTION  
JULY 2022



ALASKA ENERGY AUTHORITY		
PROJECT:	NAPASKIAK POWER SYSTEM UPGRADE	
TITLE:	200 GALLON DAY TANK FABRICATION	
DRAWN BY: JTD	DESIGNED BY: BCG	SCALE: AS NOTED
FILE NAME: NAPS PP M2-7	PROJECT NUMBER:	DATE: 7/29/22
Gray Stassel Engineering, Inc.		SHEET: M5.4
P.O. 111405, Anchorage, AK 99511 (907)349-0100		

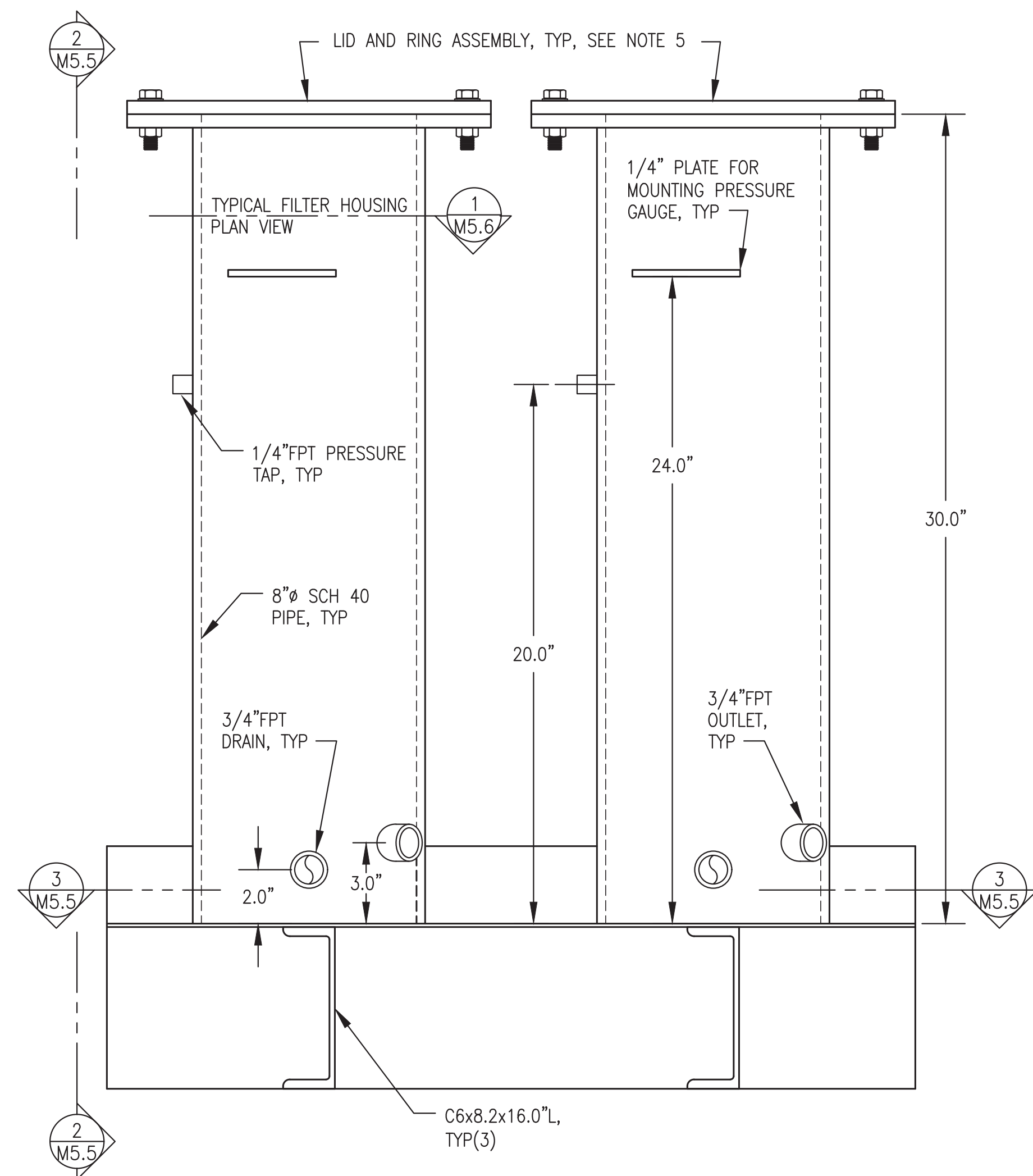

1 OIL FILTER BANK FRONT ELEVATION  
1/4" = 1"

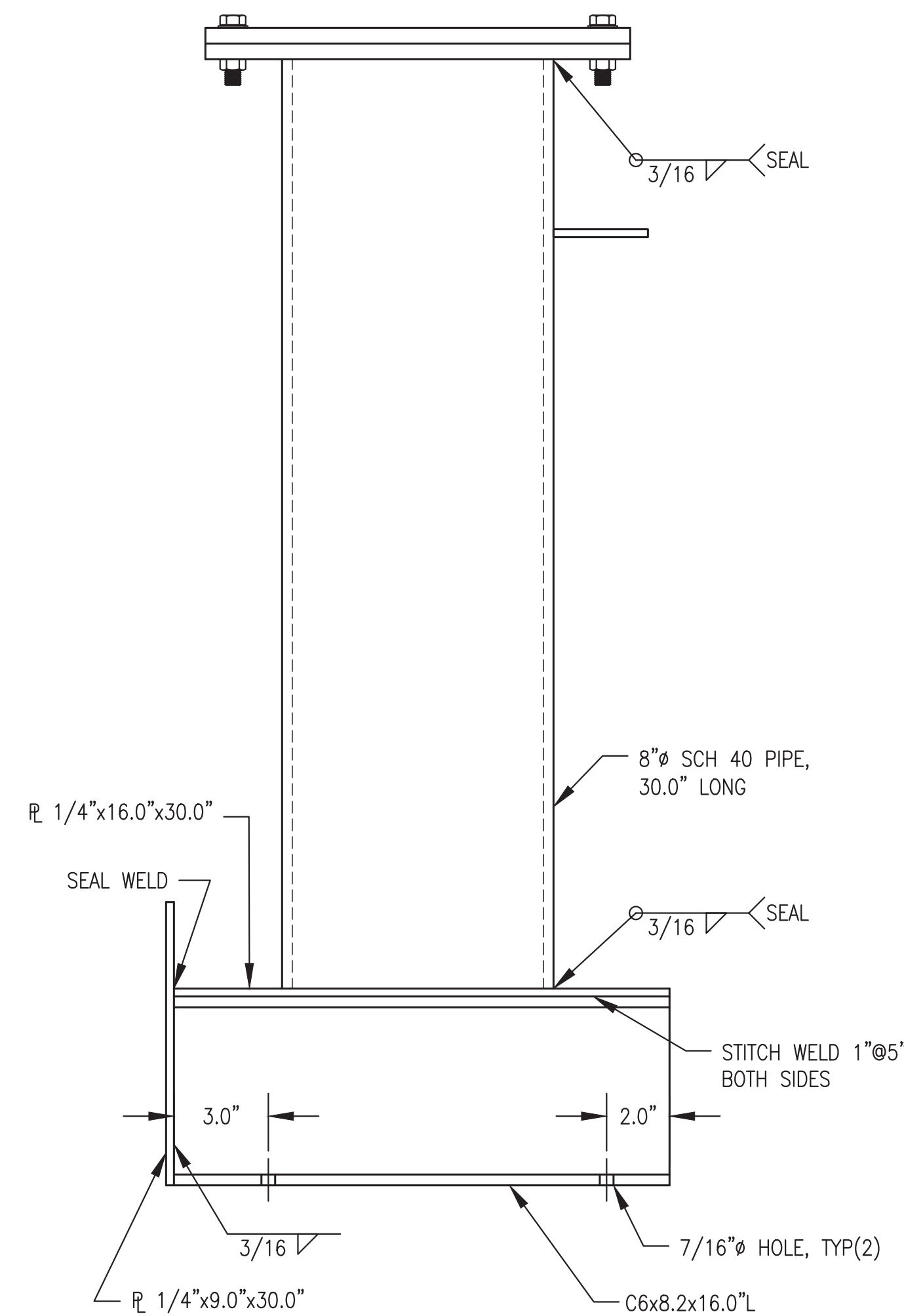

2 SECTION THROUGH FILTER & BASE  
1/4" = 1"

FILTER BANK GENERAL NOTES:

1. FABRICATE TWO CHAMBER FILTER BANK AS INDICATED. SEE SHEET M5.5 FOR INTERNAL DETAILS.
2. FABRICATE FROM ASTM A-36 STEEL PLATE AND SHAPES AND ASTM A-53 PIPE. ALL JOINTS TO BE FULL CONTINUOUS SEAL WELDS EXCEPT WHERE SPECIFICALLY INDICATED OTHERWISE.
3. PROVIDE WITH ALL OPENINGS AND ATTACHMENTS INDICATED. INSTALL MINIMUM 3,000# FORGED STEEL HALF COUPLINGS FOR ALL FPT OPENINGS IN ACCORDANCE WITH UL 142 FIGURE 7.1 - #2.
4. PRESSURE TEST COMPLETED ASSEMBLY TO MINIMUM 50 PSIG USING SOAPY WATER SOLUTION ON ALL WELD JOINTS.
5. UPON COMPLETION OF FABRICATION, ROUND ALL CORNERS AND SHARP EDGES. SANDBLAST TANK EXTERIOR AND ALL ATTACHMENTS IN ACCORDANCE WITH SSPC-SP-6. PAINT WITH TWO COATS EPOXY, PPG AMERLOC 2 VOC OR APPROVED EQUAL, COLOR ANSI 61 GRAY.
6. AFTER PAINTING REMOVE LID, WIRE BRUSH MATING SURFACES OF LID AND RING TO REMOVE ALL PAINT AND POLISH SURFACES SMOOTH. APPLY A LIGHT COAT OF GREASE OR ANTI-SIEZE PASTE TO BOTH FACES PRIOR TO INSTALLING GASKET. INSTALL 13.5" O.D. FULL-FACED 1/4" BUNA-N RUBBER GASKET (ALASKA RUBBER OR EQUAL) ON FILTER LIDS.
7. FURNISH FASTENERS AS INDICATED AND COAT WITH ANTI-SIEZE.
8. PRESSURE TEST EACH FILTER HOUSING ASSEMBLY TO 50 PSIG MINIMUM.
9. UPON COMPLETION FLUSH INTERIOR OF TANK TO REMOVE ALL DIRT AND DEBRIS, AIR DRY INTERIOR, AND SEAL ALL TANK OPENINGS WITH PLASTIC PLUGS.

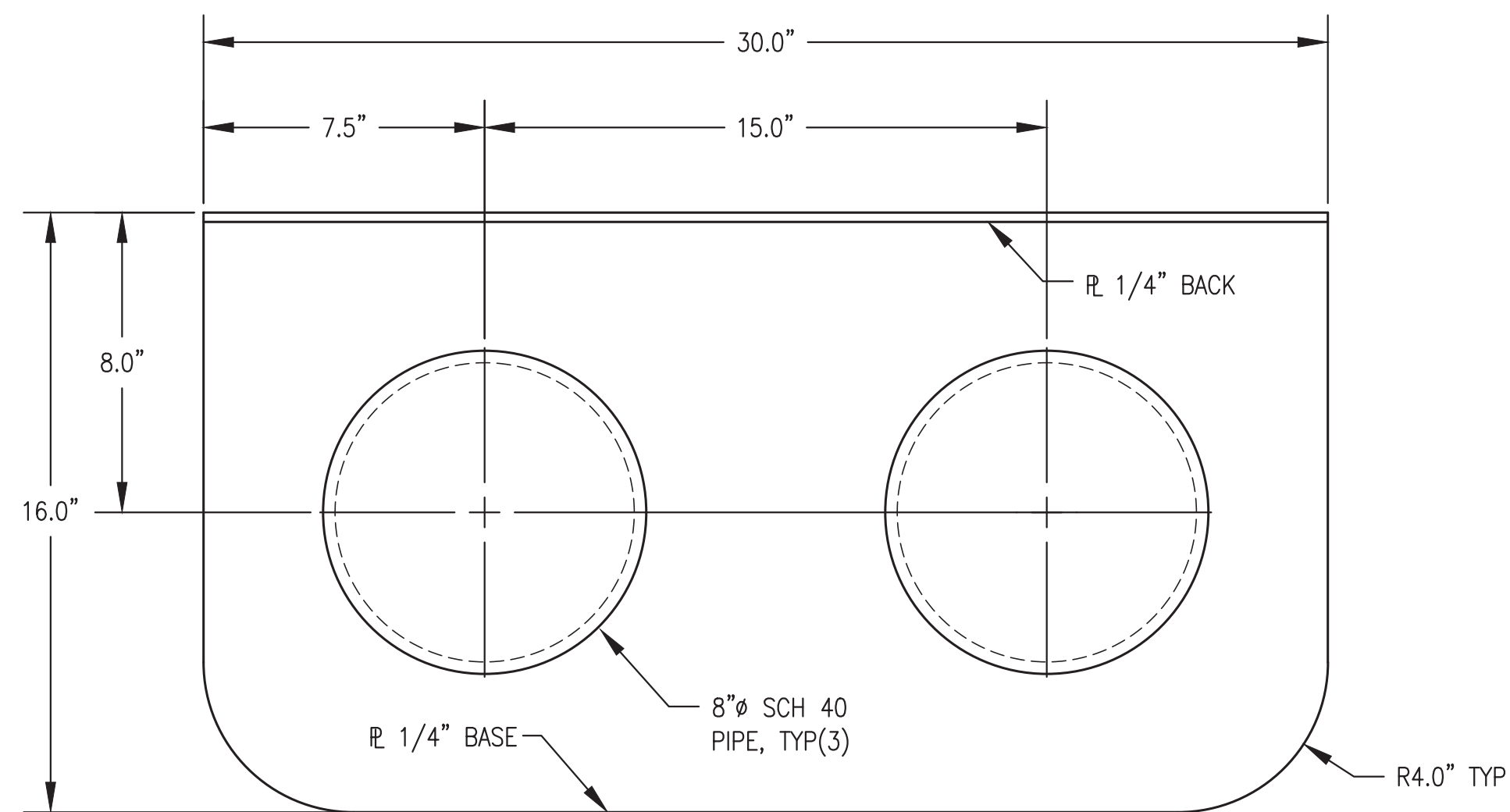

3 OIL FILTER BANK BASE PLAN  
1/4" = 1"

ALL WORK ON THIS SHEET WAS PERFORMED AS PART OF THE PRIOR MODULE ASSEMBLY CONTRACT AND IS SHOWN HERE FOR REFERENCE ONLY.

ISSUED FOR CONSTRUCTION  
JULY 2022

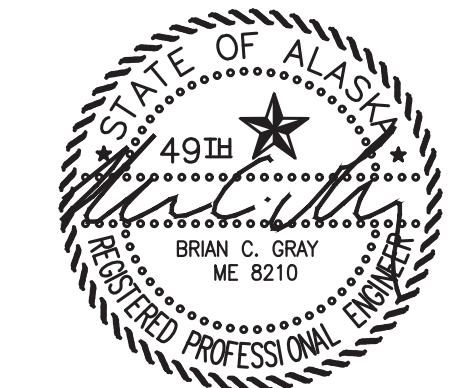

PROJECT: NAPASKIAK POWER SYSTEM UPGRADE	
TITLE: USED OIL BLENDER FILTER BANK LAYOUT & CONFIGURATION	
DRAWN BY: JTD	SCALE: AS NOTED
DESIGNED BY: BCG	DATE: 7/29/22
FILE NAME: NAPS PP M2-7	SHEET: M5.5
PROJECT NUMBER:	
P.O. 111405, Anchorage, AK 99511 (907)349-0100	

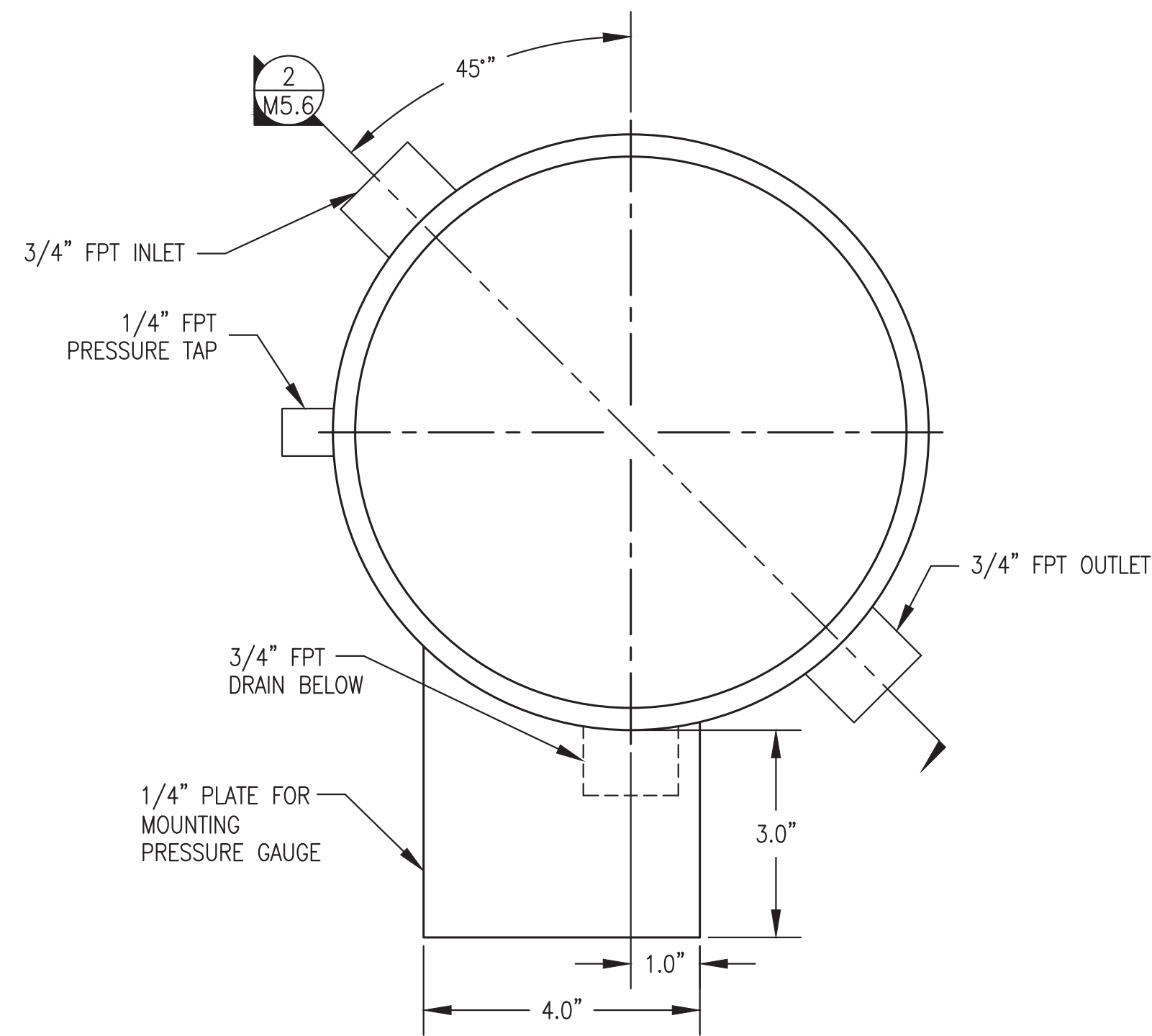

**1** TYPICAL FILTER HOUSING – PLAN VIEW  
 M5.6 1/2" = 1"

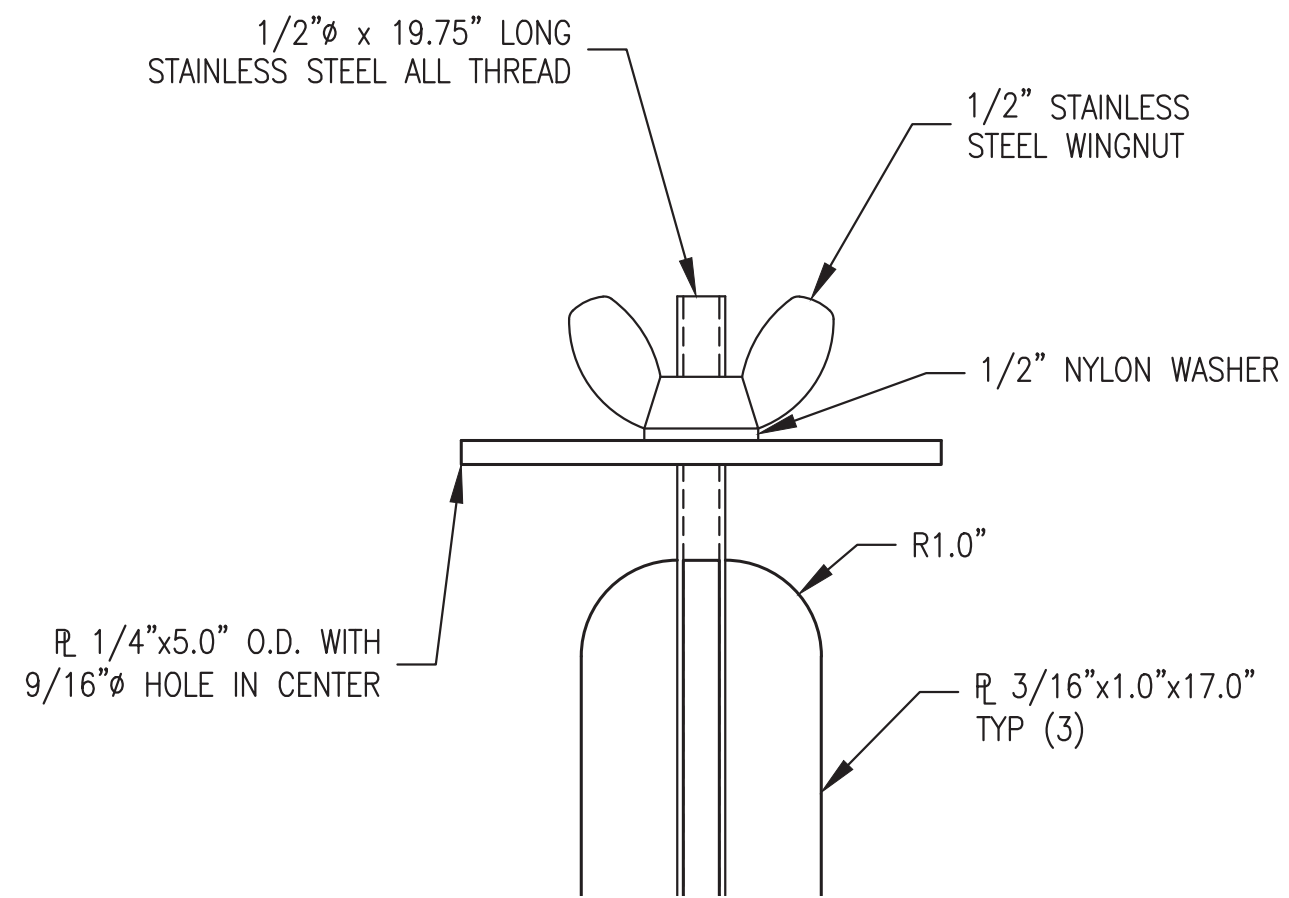

**3** ELEMENT RETAINER CAP  
 M5.6 1/2" = 1"

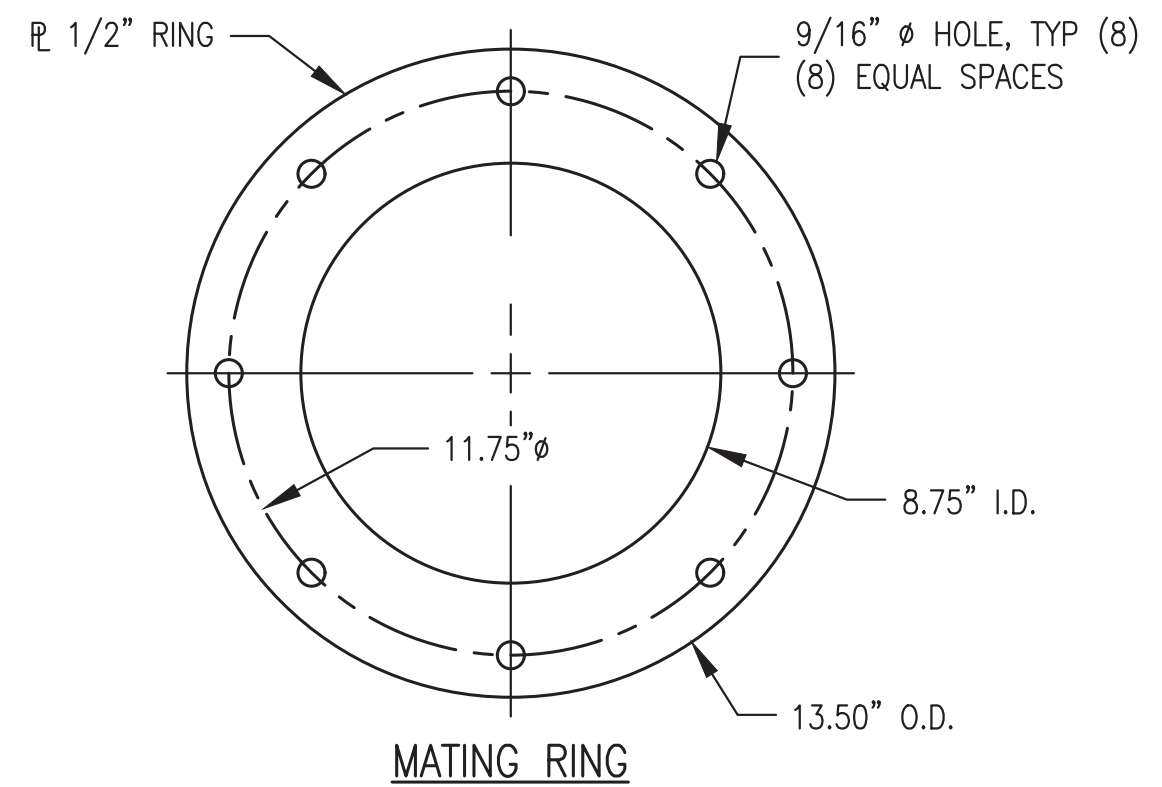
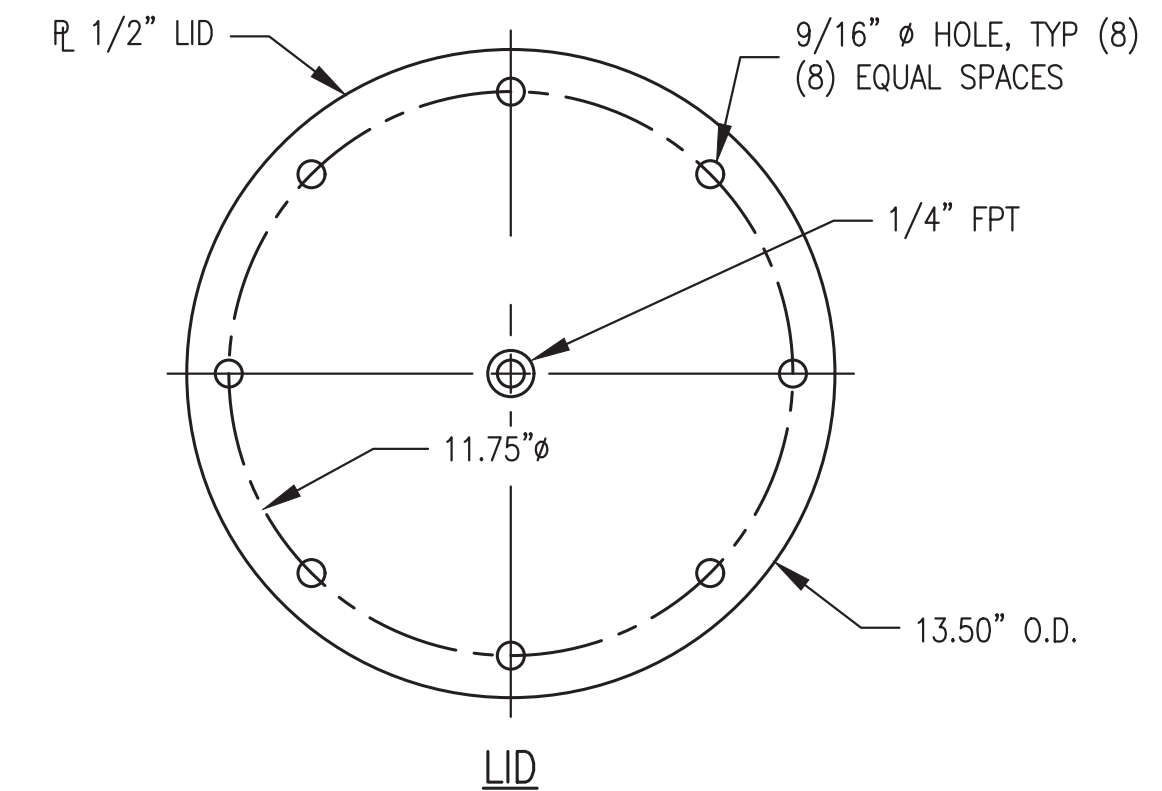

**6** LID & MATING RING – PLAN VIEW  
 M5.6 1/4" = 1"

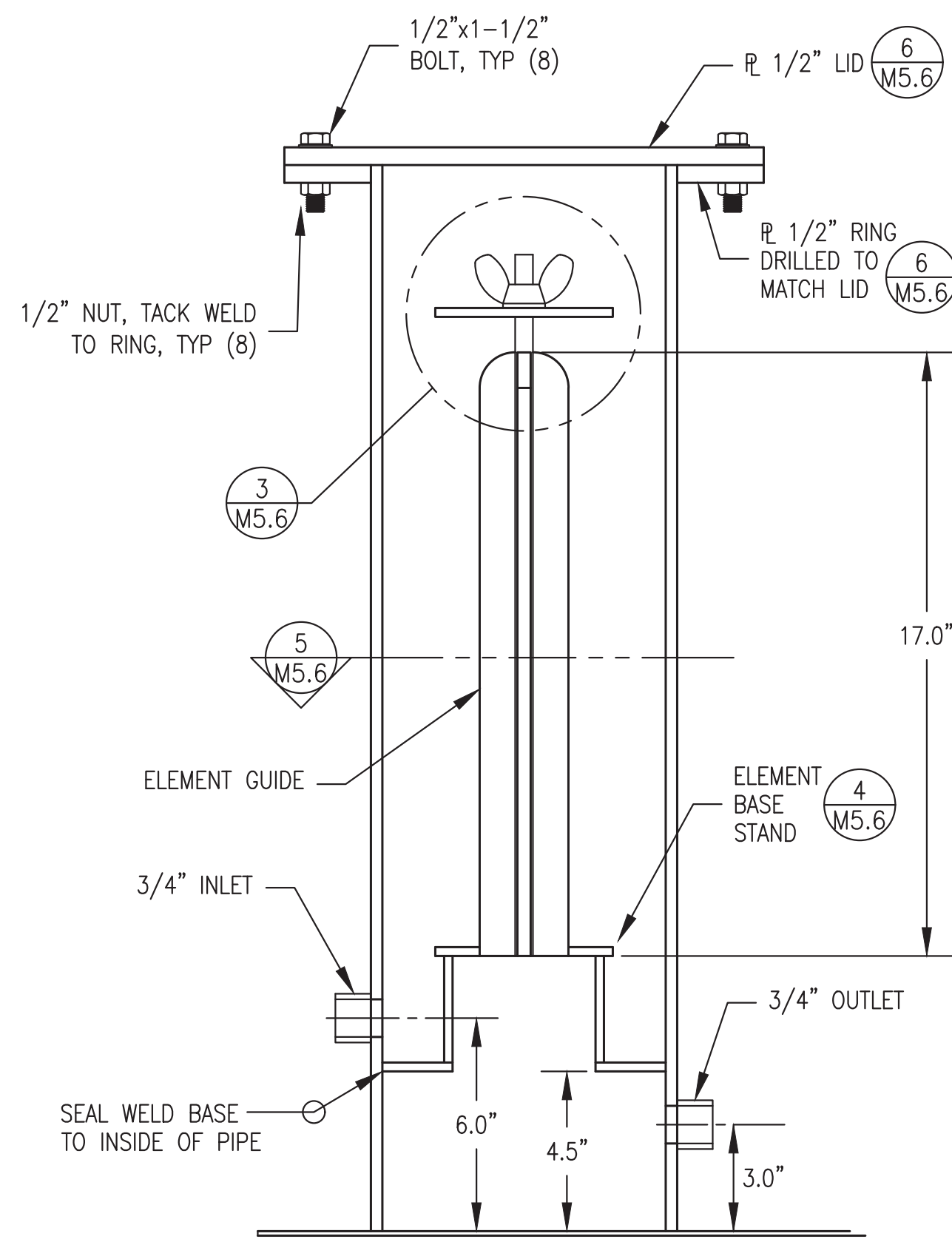

**2** TYPICAL SECTION THROUGH FILTER HOUSING  
 M5.6 1/4" = 1"

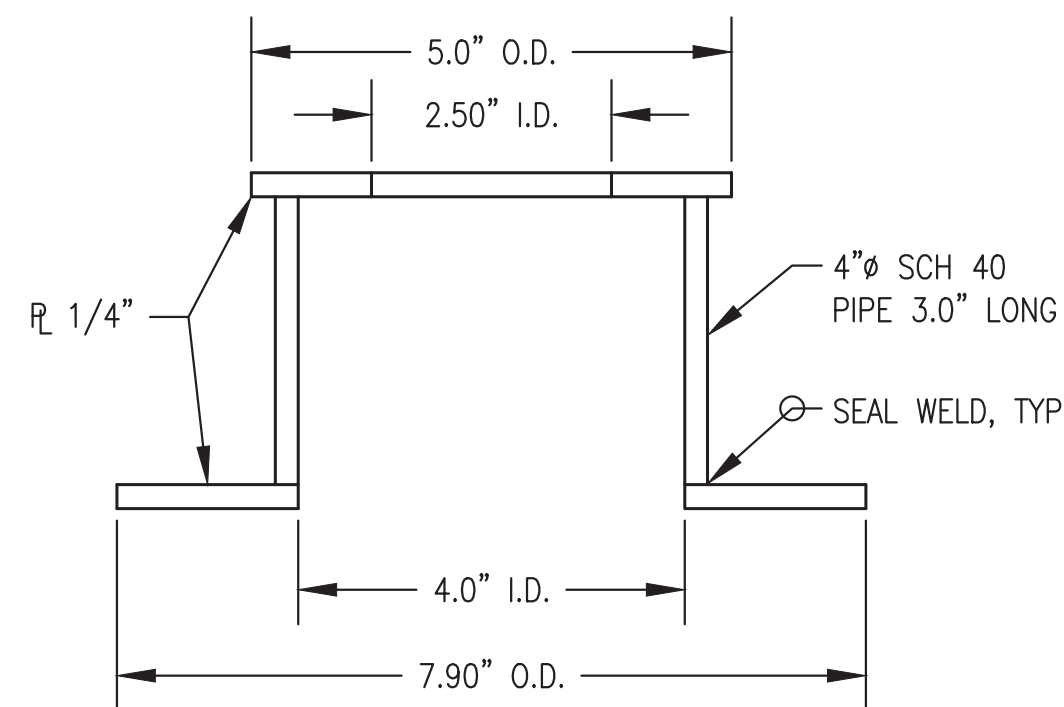

**4** ELEMENT BASE STAND  
 M5.6 1/2" = 1"

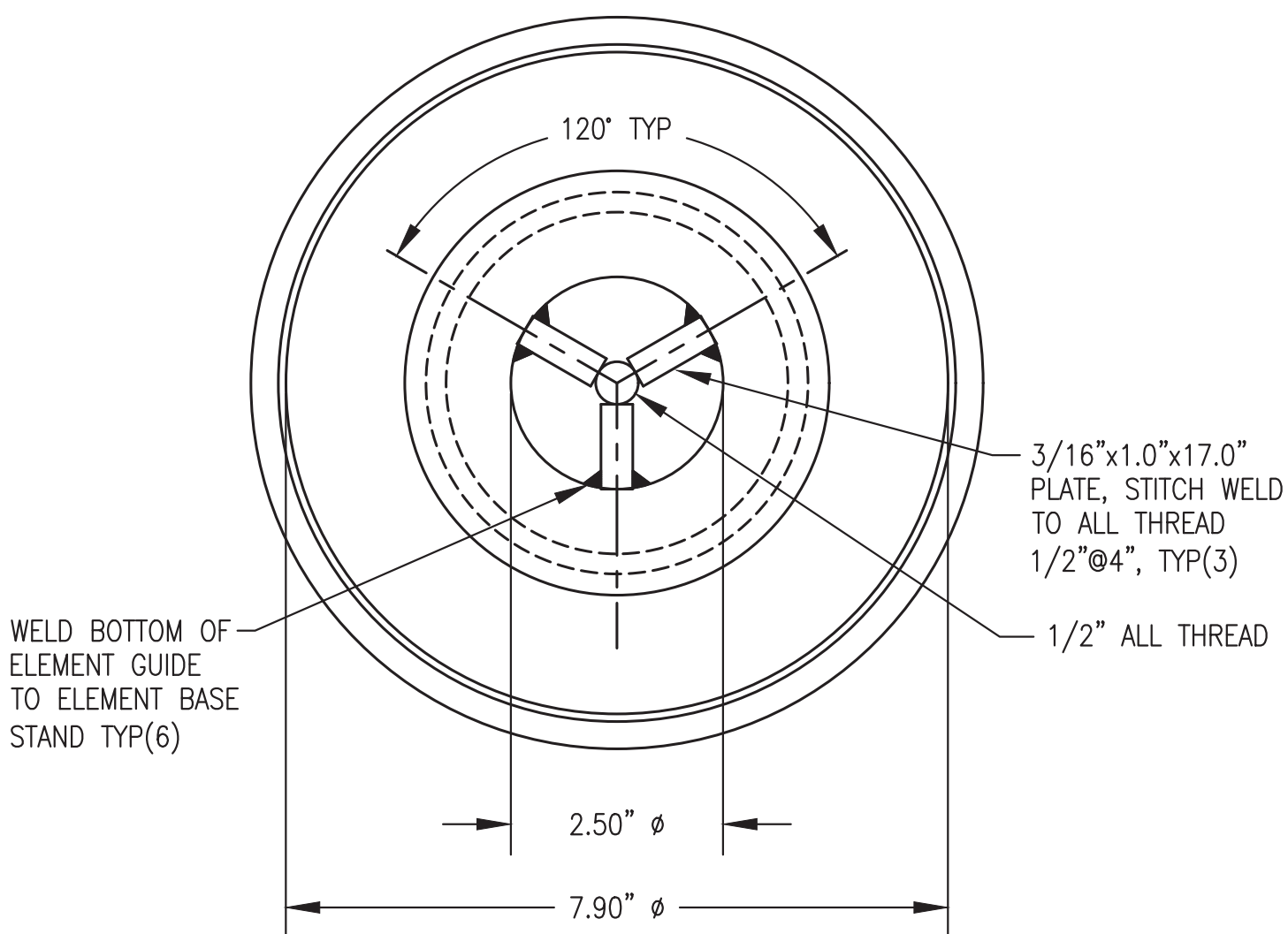

**5** SECTION THROUGH ELEMENT GUIDE  
 M5.6 1/2" = 1"

ALL WORK ON THIS SHEET WAS PERFORMED AS PART OF THE PRIOR MODULE ASSEMBLY CONTRACT AND IS SHOWN HERE FOR REFERENCE ONLY.

ISSUED FOR CONSTRUCTION  
 JULY 2022



PROJECT: NAPASKIAK POWER SYSTEM UPGRADE		
TITLE: USED OIL BLENDER TYPICAL FILTER HOUSING DETAILS		
DRAWN BY: JTD	DESIGNED BY: BCG	SCALE: AS NOTED
FILE NAME: NAPS PP M2-7	PROJECT NUMBER:	SHEET: M5.6
P.O. 111405, Anchorage, AK 99511 (907)349-0100		

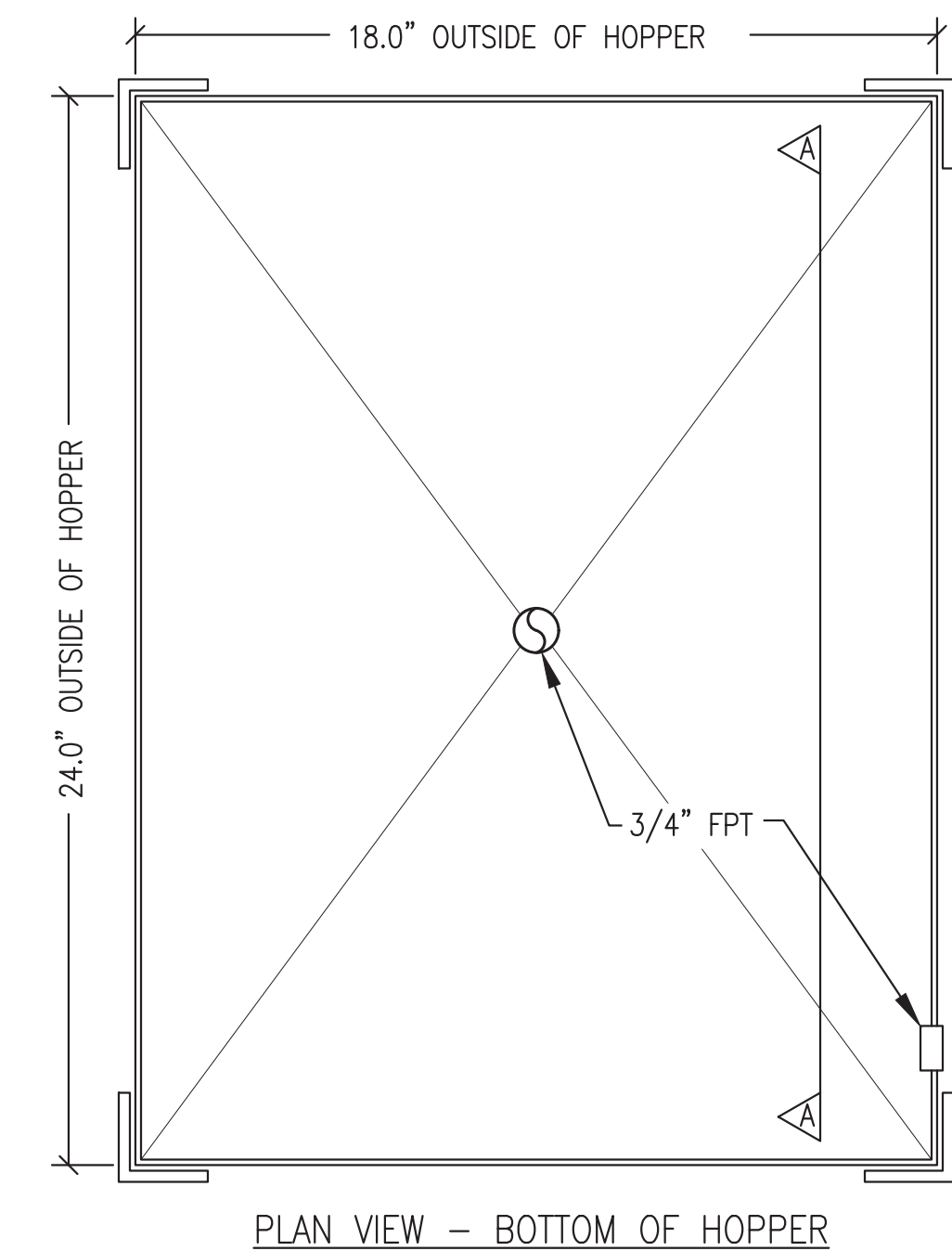
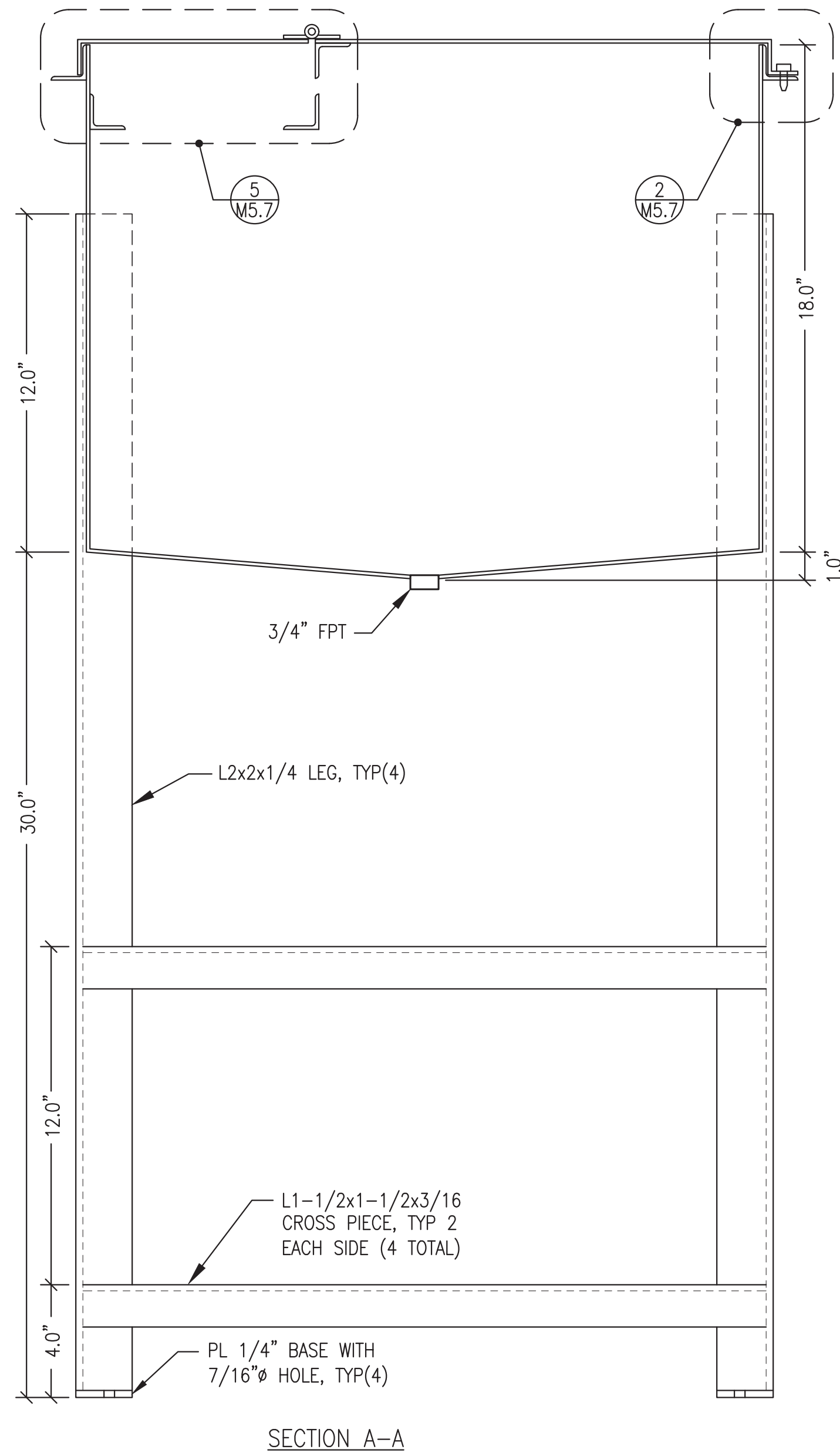
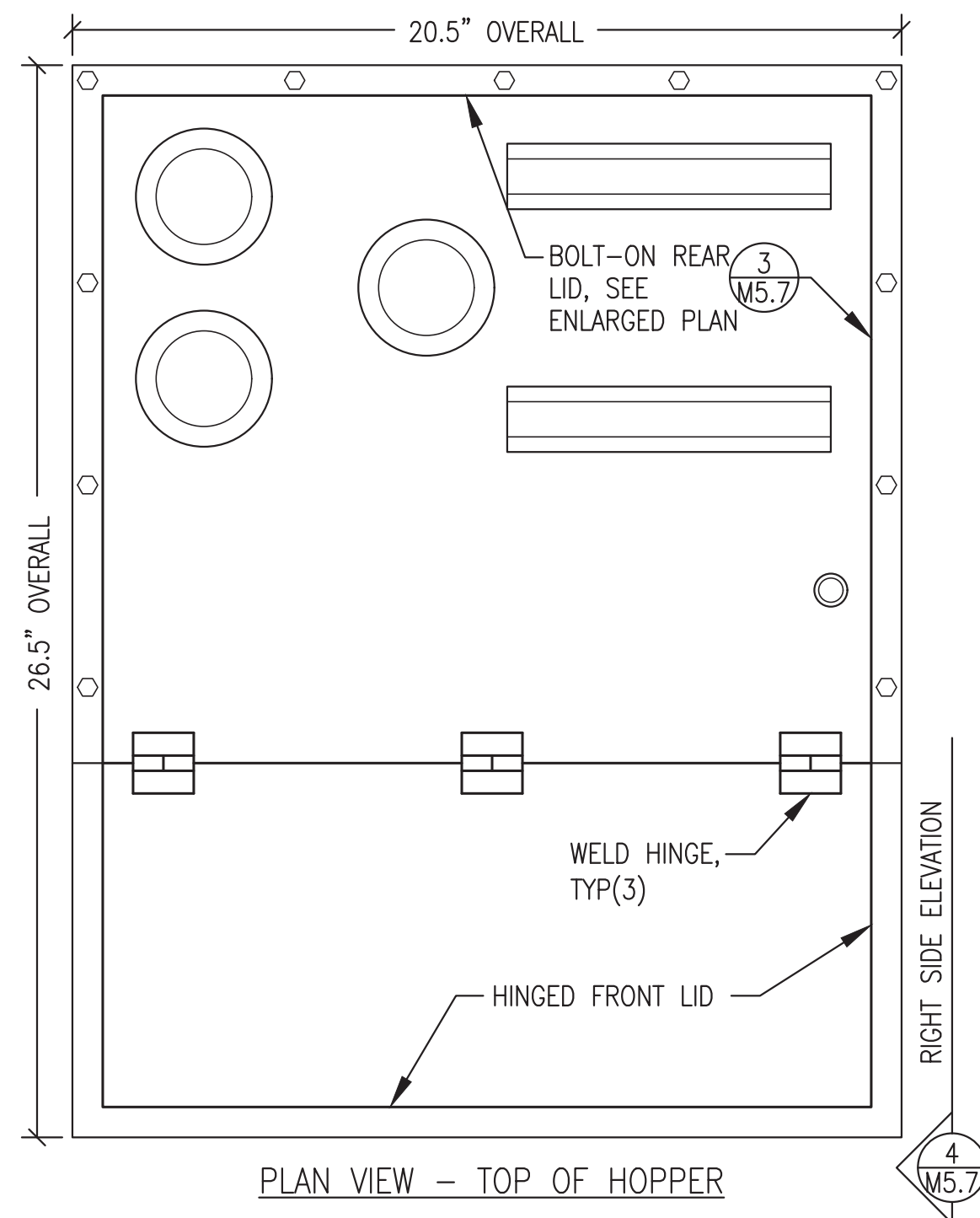

1 M5.7 HOPPER PLAN & SECTION  
3"=1'-0"

FABRICATION NOTES:

- 1) FABRICATE SINGLE WALL 25 GALLON USABLE CAPACITY HOPPER.
- 2) FABRICATE FROM MINIMUM 10 GAUGE ASTM A-36 STEEL PLATE. ALL TANK SEAM JOINTS TO BE FULL CONTINUOUS WELDS. SEAL WELD ALL TANK ATTACHMENTS.
- 3) PROVIDE WITH ALL OPENINGS AND ATTACHMENTS INDICATED. INSTALL ALL FPT OPENINGS IN ACCORDANCE WITH UL 142 FIGURE 7.1 - #1, #2, #4, OR #6. ALL STRUT TO BE 1-5/8"x1-5/8"x12 GA SOLID BACK PLAIN (BLACK), B-LINE B22 PLN OR EQUAL. FURNISH ALL FASTENERS AS INDICATED.
- 4) UPON COMPLETION OF FABRICATION, ROUND ALL CORNERS AND SHARP EDGES. SANDBLAST TANK EXTERIOR AND ALL ATTACHMENTS IN ACCORDANCE WITH SSPC-SP-6. PAINT WITH TWO COATS EPOXY, PPG AMERLOC 2 VOC OR APPROVED EQUAL, COLOR ANSI 61 GRAY.
- 5) PRIOR TO SHIPPING, SEAL ALL FPT OPENINGS WITH PLASTIC OR STEEL PLUGS.

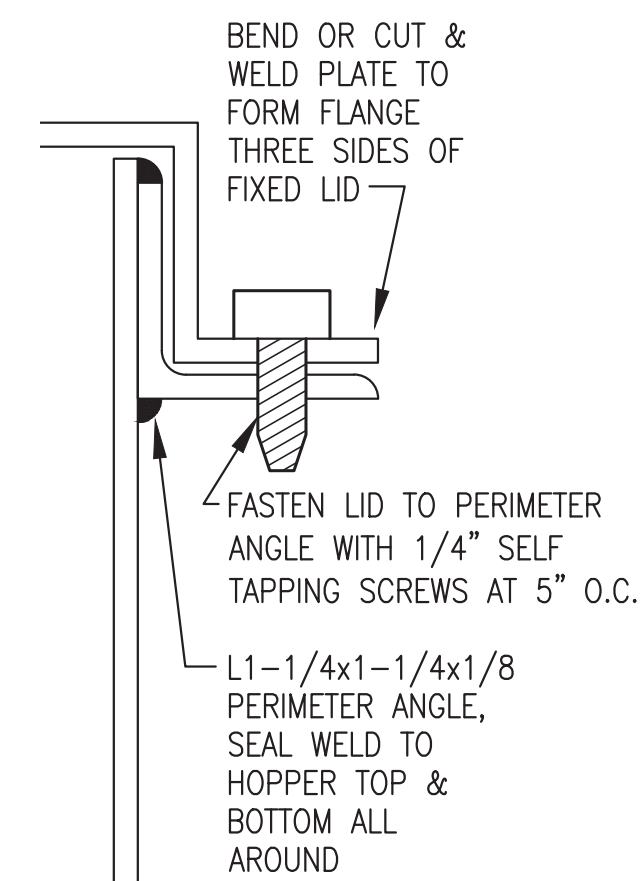

2 M5.7 FIXED LID PERIMETER ATTACHMENT  
12"=1'-0"

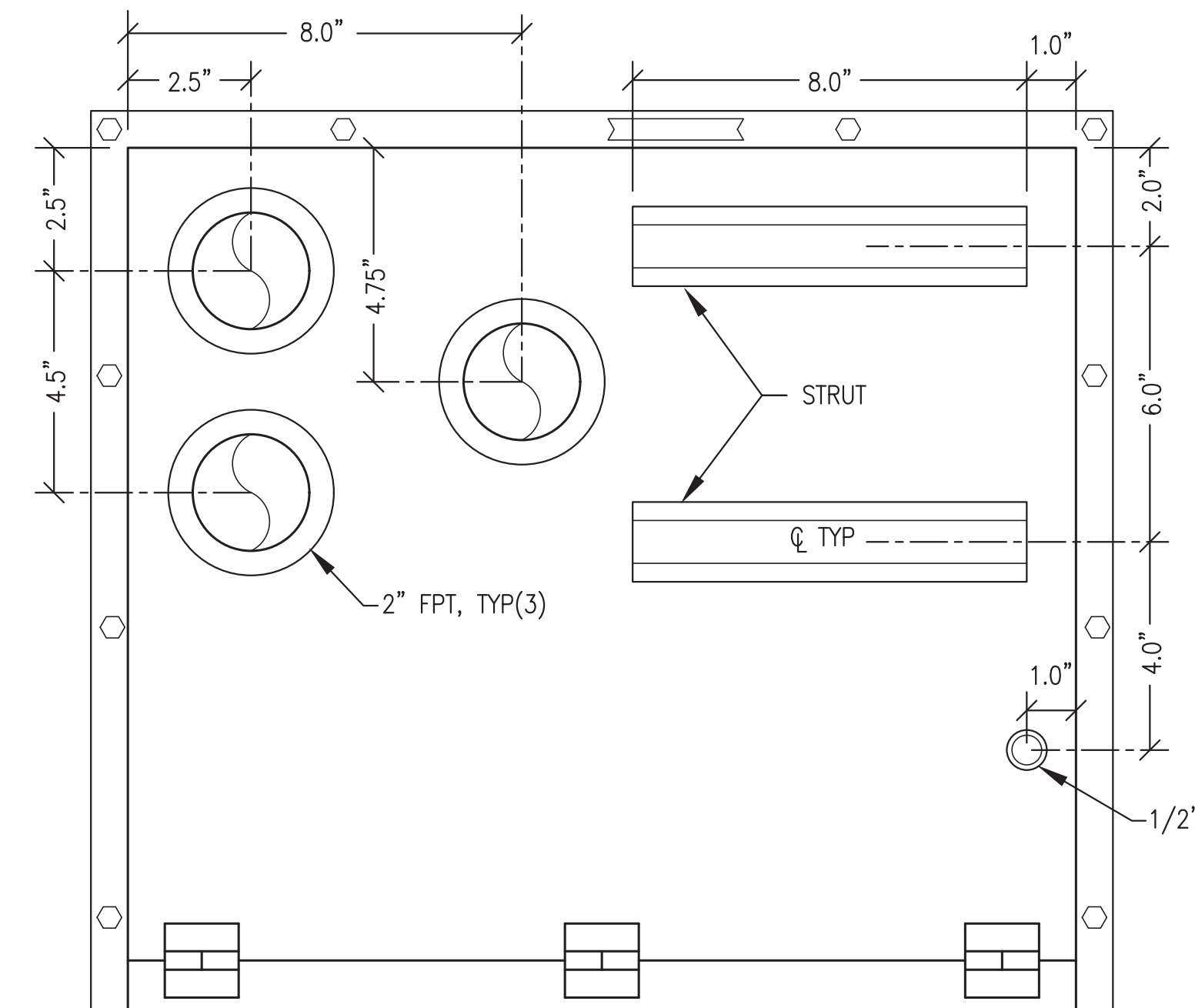

3 M5.7 FIXED LID ENLARGED PLAN VIEW  
4"=1'-0"

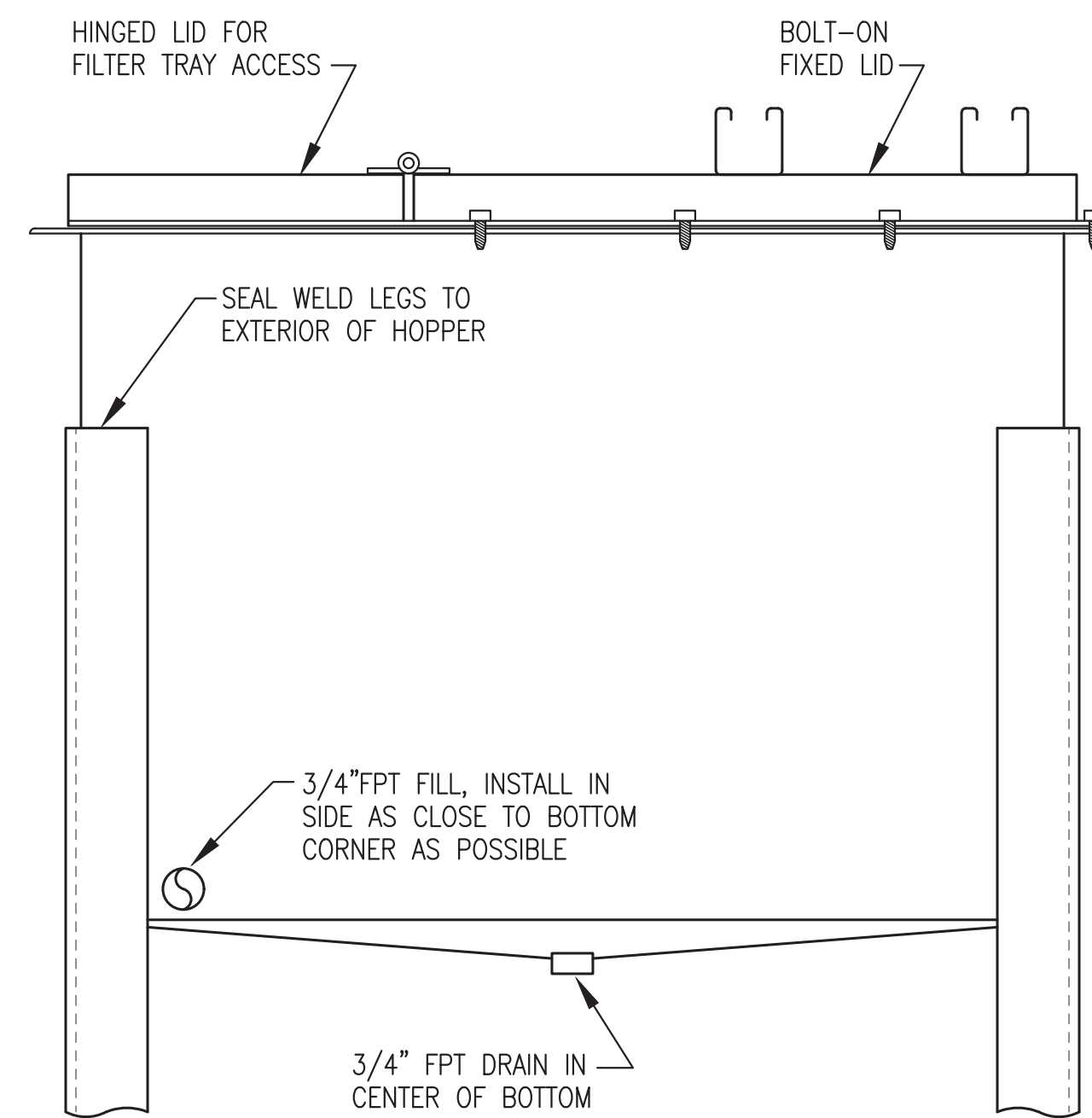

4 M5.7 HOPPER RIGHT SIDE ELEVATION  
3"=1'-0"

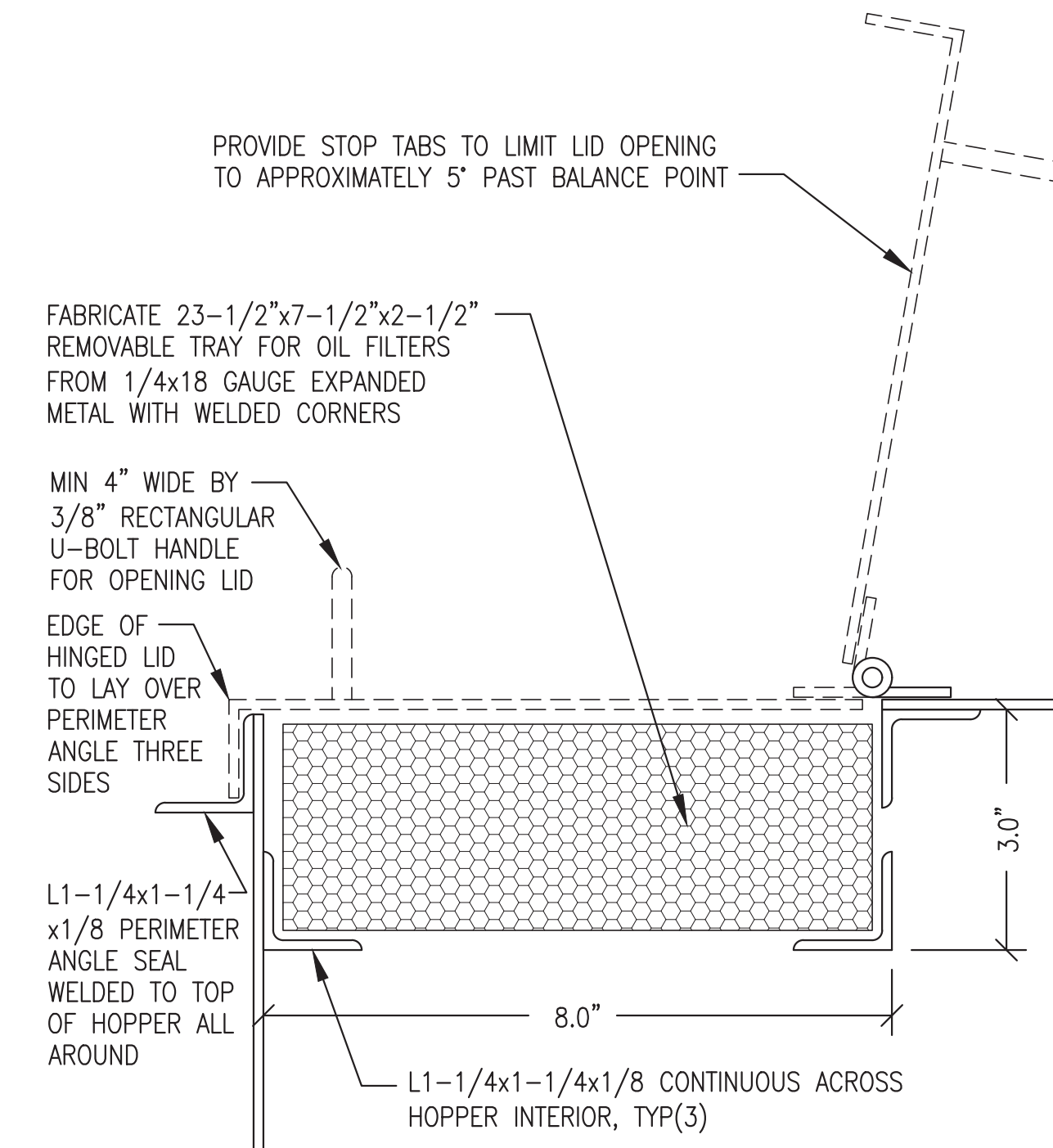

5 M5.7 HINGED LID & FILTER TRAY DETAIL  
6"=1'-0"

ALL WORK ON THIS SHEET WAS PERFORMED AS PART OF THE PRIOR MODULE ASSEMBLY CONTRACT AND IS SHOWN HERE FOR REFERENCE ONLY.

ISSUED FOR CONSTRUCTION  
JULY 2022



ALASKA ENERGY AUTHORITY	
PROJECT: NAPASKIAK POWER SYSTEM UPGRADE	
TITLE: USED OIL BLENDER 25 GALLON HOPPER FABRICATION	
 Gray Stassel Engineering, Inc. P.O. 111405, Anchorage, AK 99511 (907)349-0100	DRAWN BY: JTD DESIGNED BY: BCG FILE NAME: NAPS PP M2-7 PROJECT NUMBER:
SCALE: AS NOTED DATE: 7/29/22 SHEET: M5.7	

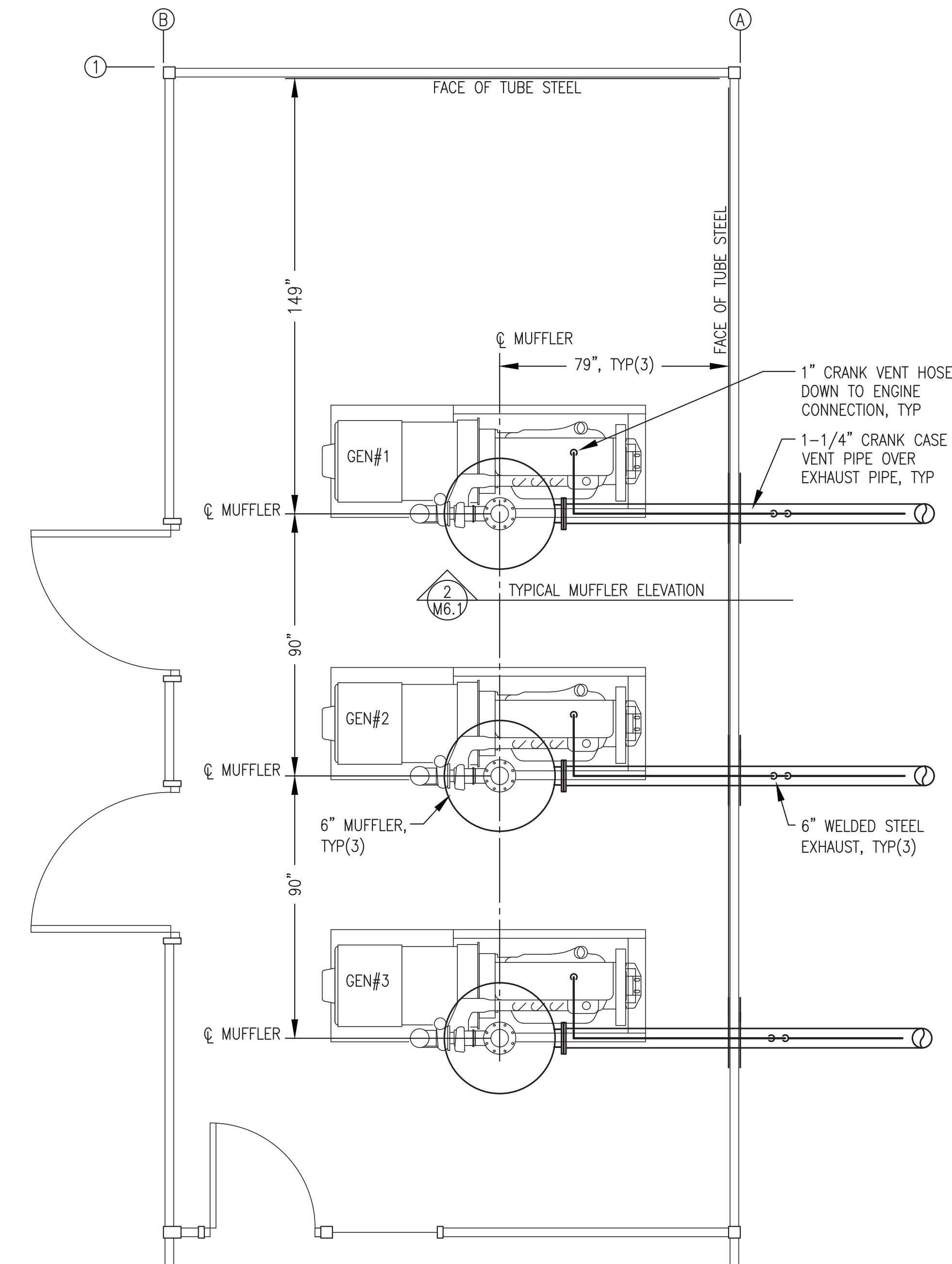

**1** MUFFLER, EXHAUST & CRANK VENT PIPE PLAN  
 M6.1 3/8"=1'-0"

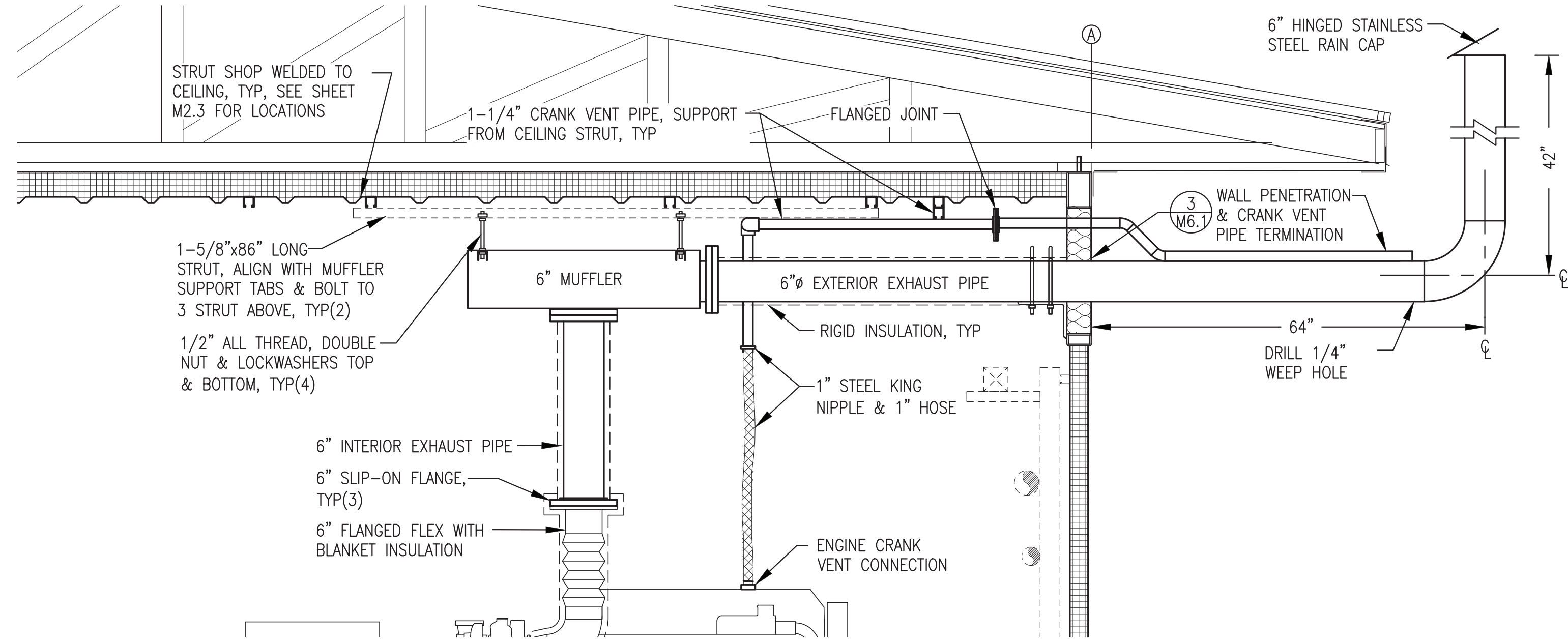

**2** TYPICAL MUFFLER, EXHAUST, AND CRANK VENT PIPE INSTALLATION  
 M6.1 3/4"=1'-0"

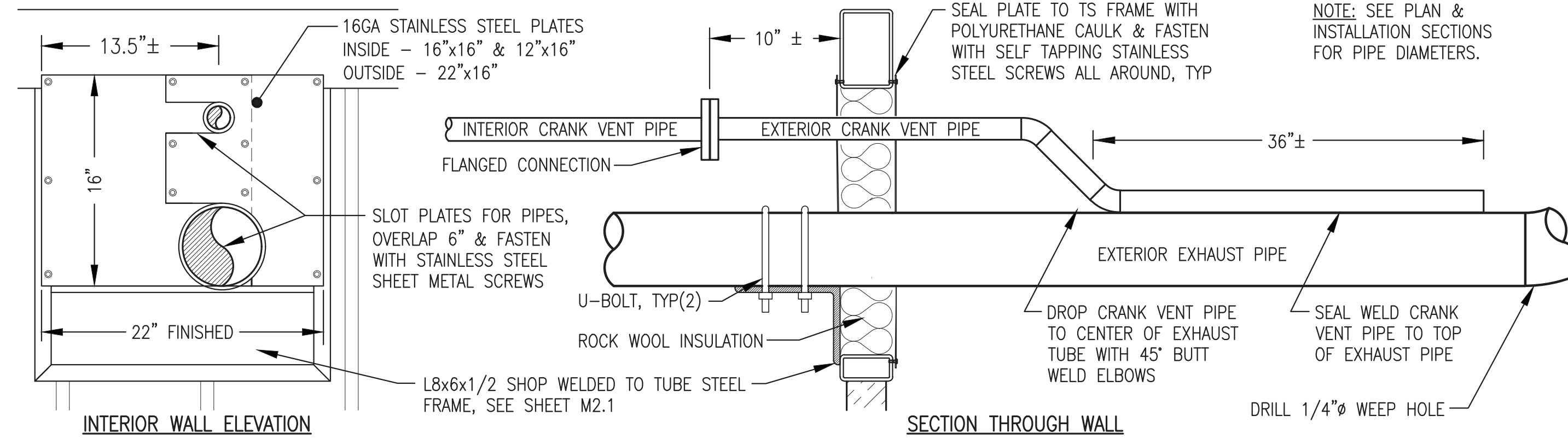

**3** WALL PENETRATION & CRANK VENT PIPE TERMINATION  
 M6.1 NO SCALE

**EXHAUST & CRANK VENT GENERAL NOTES:**

- 1) THE MAXIMUM EXHAUST TEMPERATURE FOR THE ENGINES IS LESS THAN 1400°F. THE WALLS AND CEILING ARE NON-COMBUSTIBLE CONSTRUCTION CONSISTING OF STEEL WITH HIGH TEMPERATURE ROCKWOOL INSULATION.
- 2) ALL EXTERIOR EXHAUST PIPE AND FITTINGS (FROM MUFFLER TO RAIN CAP) TYPE 304L STAINLESS STEEL WITH BUTT WELD FITTINGS. INTERIOR EXHAUST PIPE RISER (FROM FLEX TO MUFFLER) CARBON STEEL OR MAY BE STAINLESS AT CONTRACTORS OPTION. ALL FLANGES ANSI 150# FLAT FACED SLIP ON.
- 3) ALL EXTERIOR CRANK VENT PIPE AND FITTINGS TYPE 304L STAINLESS STEEL WITH BUTT WELD FITTINGS. ALL INTERIOR CRANK VENT PIPE AND FITTINGS CARBON STEEL WITH SOCKET WELD FITTINGS OR MAY BE STAINLESS AT CONTRACTORS OPTION. ALL FLANGES ANSI 150# RAISED FACE SOCKET WELD.
- 4) ALL EXHAUST FLANGE BOLTS BLACK OR STAINLESS STEEL. COAT WITH HIGH TEMPERATURE ANTI-SIEZE COMPOUND. ALL EXHAUST FLANGE GASKETS HIGH TEMPERATURE FULL FACE.

**EXHAUST & CRANK VENT SHOP/ON-SITE NOTES:**

- 1) SHOP FABRICATE COMPLETE EXHAUST AND CRANK VENT PIPING SYSTEM AS INDICATED.
- 2) SHOP INSTALL BLANKET INSULATION ON FLEX AND RIGID INSULATION FROM FLEX TO MUFFLER. SHOP FIT INSULATION FROM MUFFLER TO WALL, LABEL FOR THE ASSOCIATED GENERATOR AND STORE INSIDE MODULE.
- 3) SHOP FABRICATE STAINLESS STEEL COVER PLATES BUT DO NOT INSTALL. LABEL COVER PLATES FOR THE ASSOCIATED GENERATOR AND STORE INSIDE MODULE. SHOP FURNISH ROCK WOOL INSULATION AND PACKAGE LOOSE SHIP WITH COVER PLATES.
- 4) UPON COMPLETION OF TESTING BREAK EXHAUST FLANGE JOINT ON MUFFLER OUTLET AND CRANK VENT FLANGE JOINT AND REMOVE U-BOLTS. REMOVE PIPING FOR SHIPPING AND TEMPORARILY SEAL WALL PENETRATION.
- 5) IN FIELD REINSTALL PIPING WITH NEW FLANGE GASKETS. RE-INSTALL PIPING INSULATION. INSULATE WALL PENETRATION, INSTALL COVER PLATES, AND SEAL TO WALL.

**ALL WORK ON THIS SHEET WAS PERFORMED AS PART OF THE PRIOR MODULE ASSEMBLY CONTRACT EXCEPT AS SPECIFICALLY INDICATED IN THE SHOP/ON SITE NOTES.**

1	REVISED TO ALIGN EXHAUST WITH MODIFIED MARINE TURBO MOUNTING	7/5/22	BCG
REV.	DESCRIPTION	DATE	BY
 ALASKA ENERGY AUTHORITY			
PROJECT: NAPASKIAK POWER SYSTEM UPGRADE			
TITLE: EXHAUST & CRANK VENT PLAN & DETAILS			
DRAWN BY: JTD		SCALE: AS NOTED	
DESIGNED BY: BCG		DATE: 7/29/22	
FILE NAME: NAPS PP M2-7		SHEET: M6.1	
PROJECT NUMBER:			
P.O. 111405, Anchorage, AK 99511 (907)349-0100			

REVISION #1  
 ISSUED  
 JULY 2023

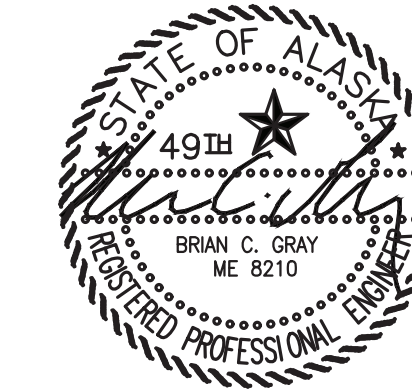

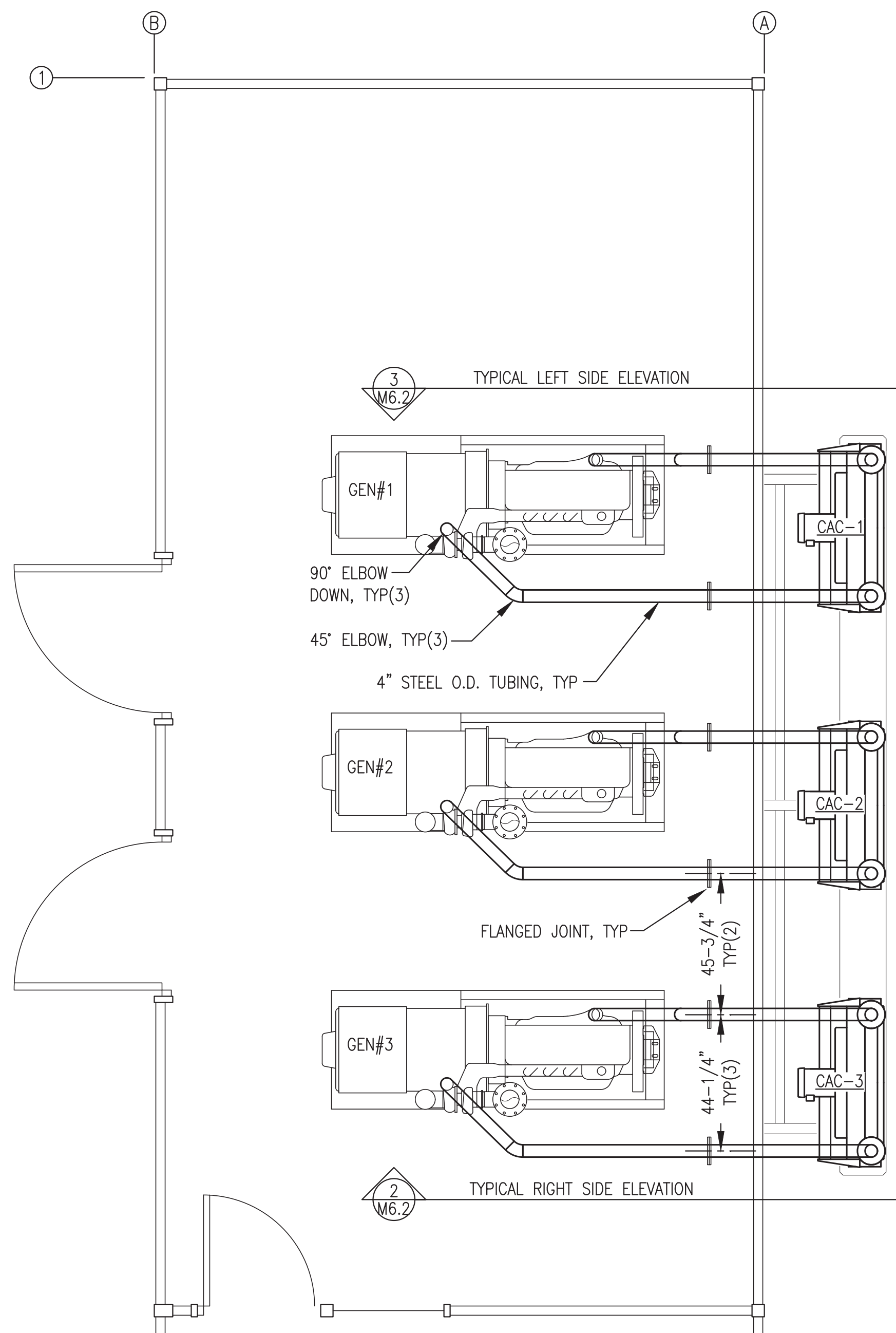

**1** CHARGE AIR PLAN  
M6.2 3/8"=1'-0"

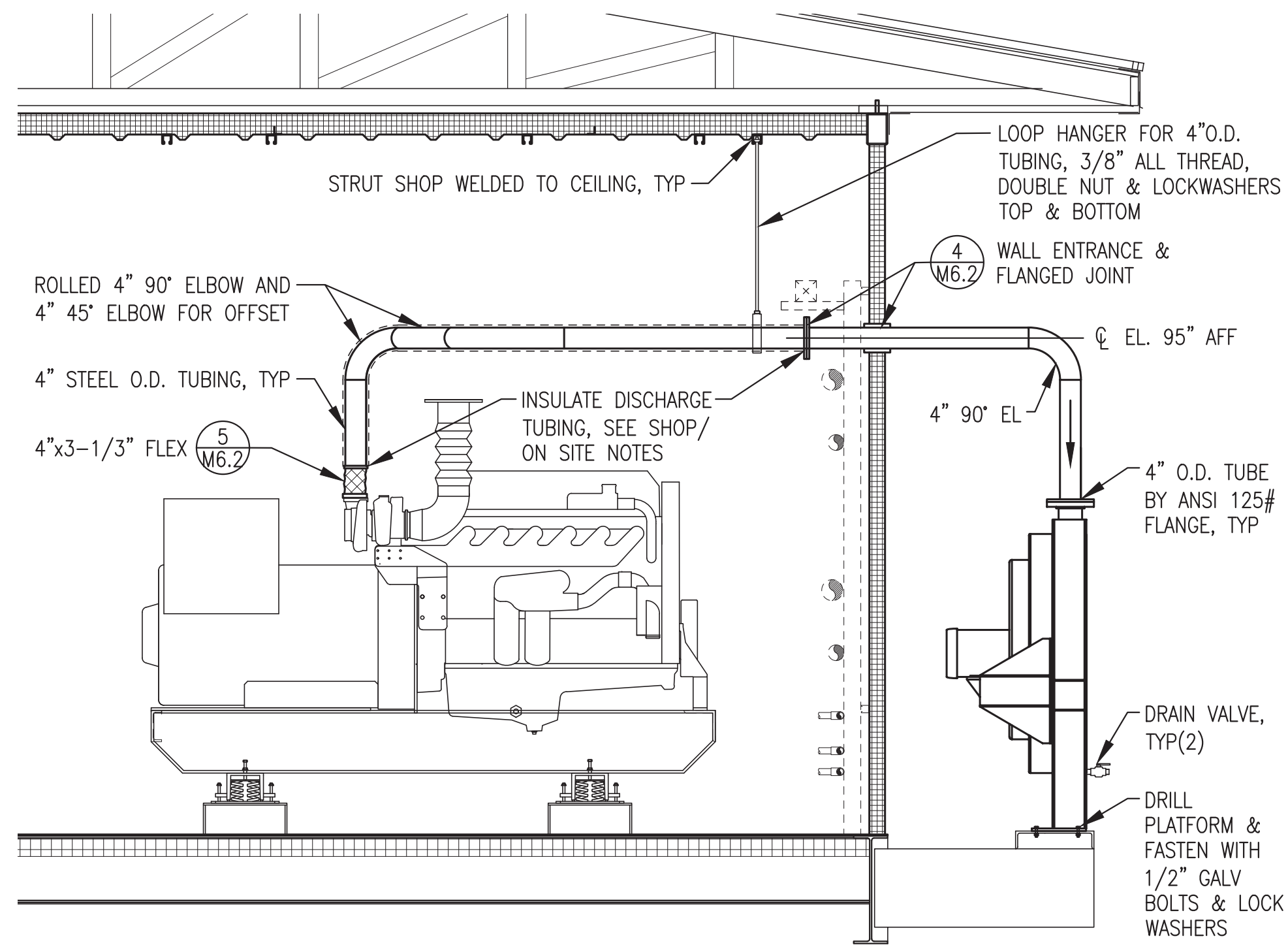

**2** TYPICAL GENERATOR CHARGE AIR RIGHT SIDE (DISCHARGE) ELEVATION  
M6.2 1/2"=1'-0"

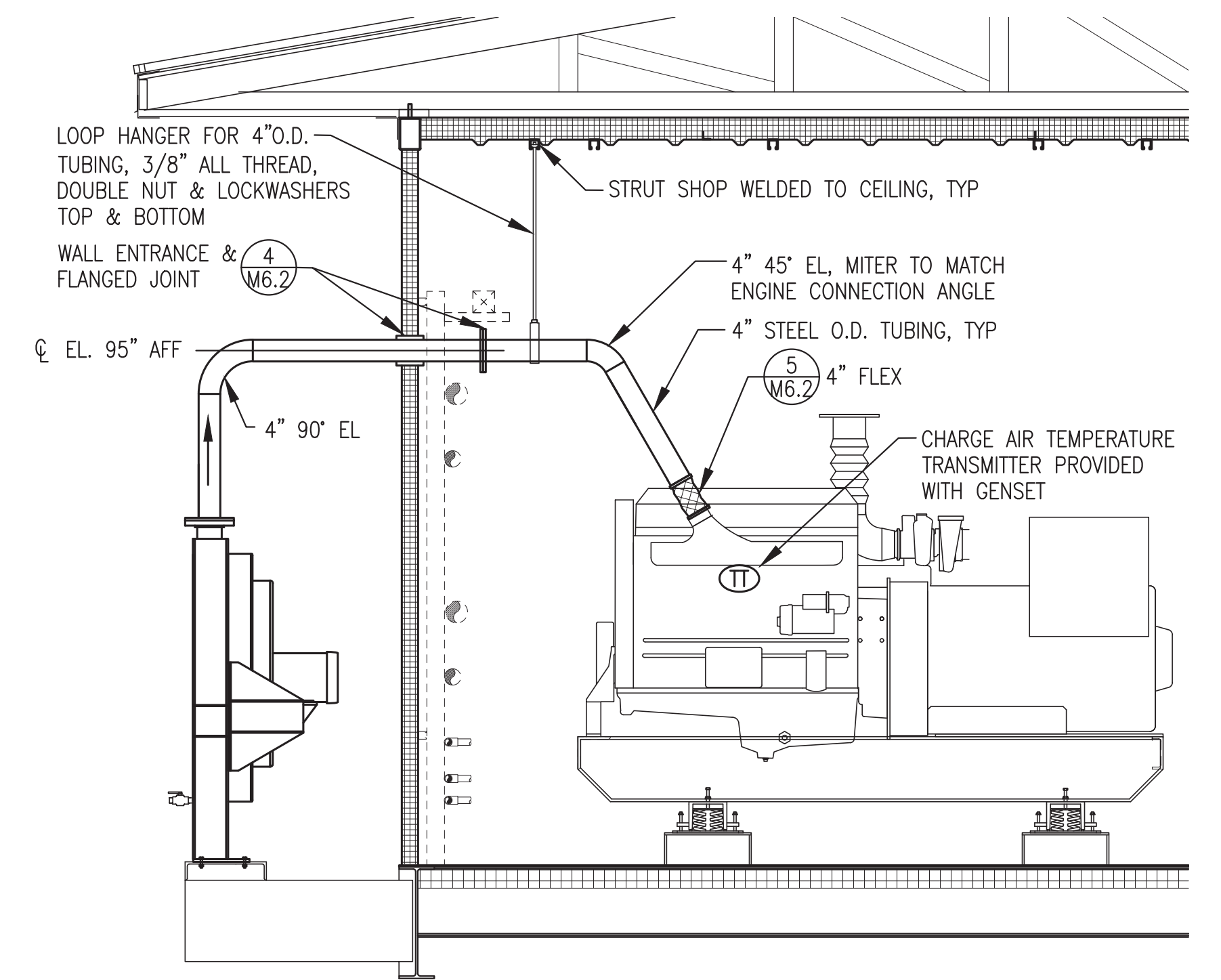

**3** TYPICAL GENERATOR CHARGE AIR LEFT SIDE (RETURN) ELEVATION  
M6.2 1/2"=1'-0"

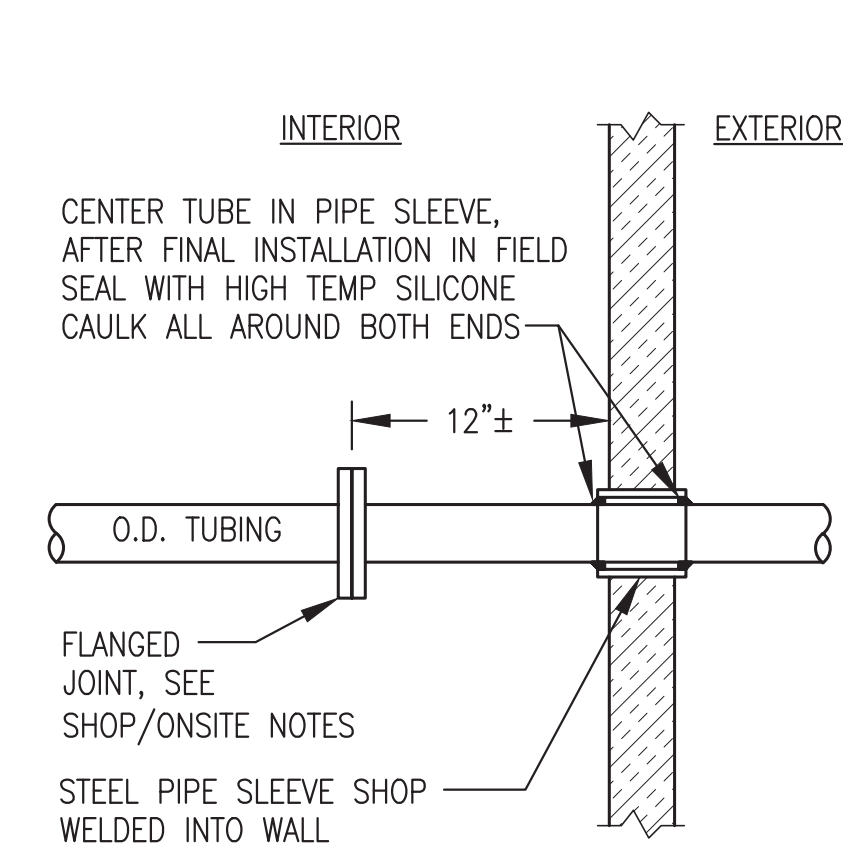

**4** TUBING WALL PENETRATION  
M6.2 NO SCALE

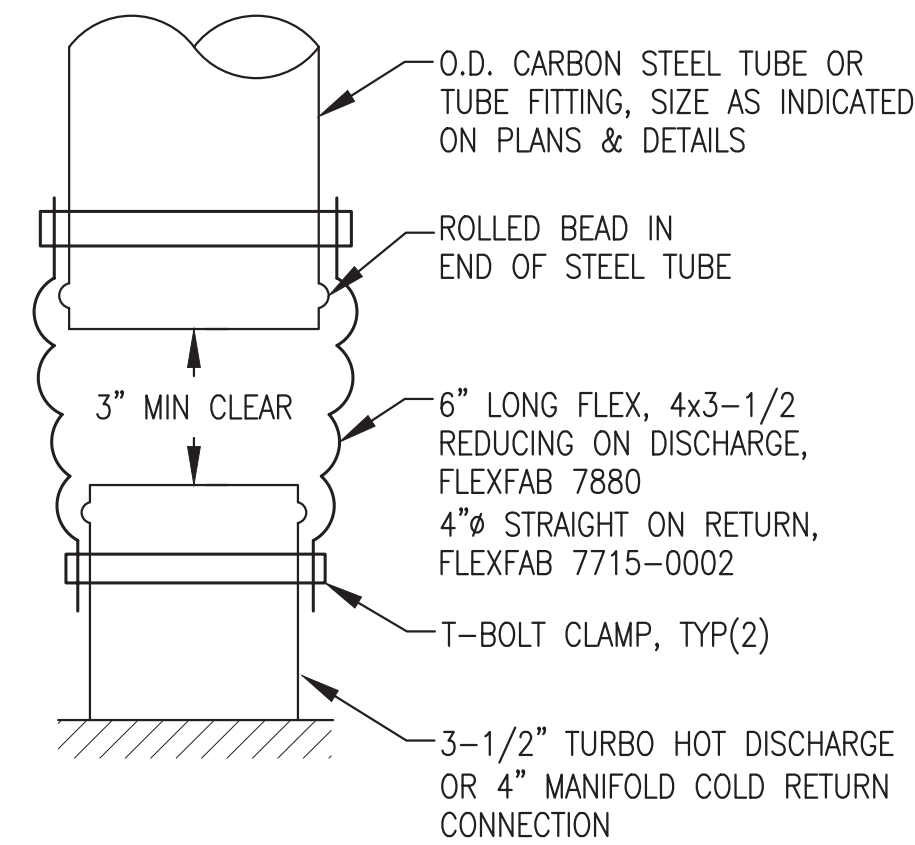

**5** CHARGE AIR FLEX CONNECTION  
M6.2 NO SCALE

**CHARGE AIR SYSTEM GENERAL NOTES:**

- 1) ALL TUBING TO BE LIGHT WALL CARBON STEEL O.D. TUBING. ALL ELBOWS TO BE LONG RADIUS SWEEP FITTINGS TO MATCH TUBING. ALL JOINTS TO BE WELDED EXCEPT AS INDICATED.
- 2) MAKE COOLER CONNECTIONS AND FLANGED JOINTS WITH O.D. TUBE BY ANSI 125# STEEL PLATE FLANGES, G.T. EXHAUST OR EQUAL.
- 3) ALL CHARGE AIR FLANGE GASKETS HIGH TEMPERATURE FULL FACE. ALL CHARGE AIR FLANGE BOLTS GALVANIZED STEEL. COAT WITH HIGH TEMPERATURE ANTI-SIEZE COMPOUND.
- 4) ALL FLEX CONNECTIONS HIGH TEMPERATURE DOUBLE HUMP SILICONE TURBO SLEEVES WITH RINGS. SEE DETAILS FOR SPECIFIC DESCRIPTIONS & PART NUMBERS. FASTEN WITH STAINLESS STEEL T-BOLT CLAMPS.

**CHARGE AIR SYSTEM SHOP/ON-SITE NOTES:**

- 1) ALL CHARGE AIR SYSTEM COMPONENTS TO BE FURNISHED AND INSTALLED AS PART OF MODULE SHOP FABRICATION INCLUDING ADDITIONAL FLANGES, GASKETS, AND BOLTS FOR ON-SITE INSTALLATION.
- 2) AS PART OF MODULE SHOP FABRICATION PAINT ALL TUBING AND FLANGES WITH COLD GALVANIZING COMPOUND. AS PART OF ON SITE WORK RE-COAT WELD AREAS AND OTHER DEFECTS.
- 3) DURING SHOP FABRICATION RUN TUBING CONTINUOUS FROM COOLER TO ENGINE.
- 4) AS PART OF BREAK DOWN FOR SHIPPING CUT TUBING 12" INSIDE WALL AT LOCATION OF FLANGE JOINT, BREAK FLANGE JOINT ON COOLER, REMOVE INTERIOR AND EXTERIOR TUBING, AND TEMPORARILY SEAL WALL PENETRATION FOR SHIPPING.
- 5) AS PART OF ON SITE WORK REINSTALL ALL TUBING, INSTALL NEW FLANGE JOINT AT CUT, INSTALL NEW HIGH TEMPERATURE FULL FACE GASKETS AT NEW JOINT AND AT COOLER, AND COAT WELD AREA THEN SEAL WALL PENETRATION.
- 6) AS PART OF ON SITE WORK INSULATE INTERIOR CHARGE AIR DISCHARGE TUBING FROM FLEX AT ENGINE TO FLANGE AT WALL PENETRATION.
- 7) AS PART OF ON SITE WORK FURNISH AND INSTALL 1/2" THREADED BALL VALVE IN COOLER AND PLUG FOR TANK DRAIN, 2 PER COOLER.

ALL WORK ON THIS SHEET WAS PERFORMED AS PART OF THE PRIOR MODULE ASSEMBLY CONTRACT EXCEPT AS SPECIFICALLY INDICATED IN THE SHOP/ON SITE NOTES.

ISSUED FOR CONSTRUCTION  
JULY 2022

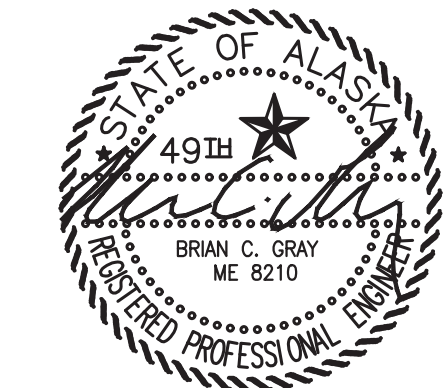

PROJECT: <b>NAPASKIAK POWER SYSTEM UPGRADE</b>	
TITLE: <b>CHARGE AIR SYSTEM PLAN, ELEVATIONS, &amp; DETAILS</b>	
DRAWN BY: JTD	SCALE: AS NOTED
DESIGNED BY: BCG	DATE: 7/29/22
FILE NAME: NAPS PP M2-7	SHEET:
P.O. 111405, Anchorage, AK 99511 (907)349-0100	PROJECT NUMBER: <b>M6.2</b>

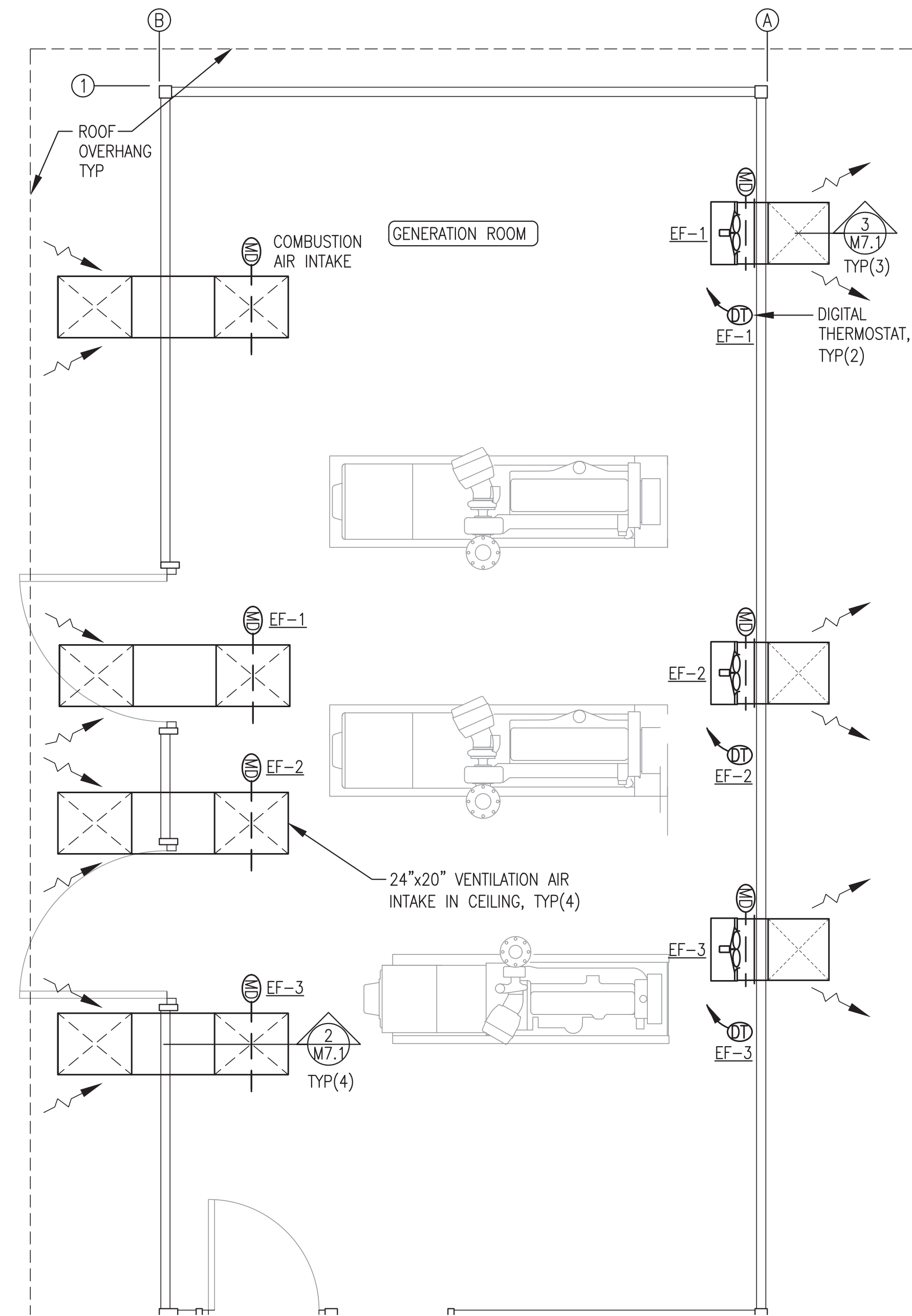

**1** VENTILATION PLAN  
M7.1 3/8"=1'-0"

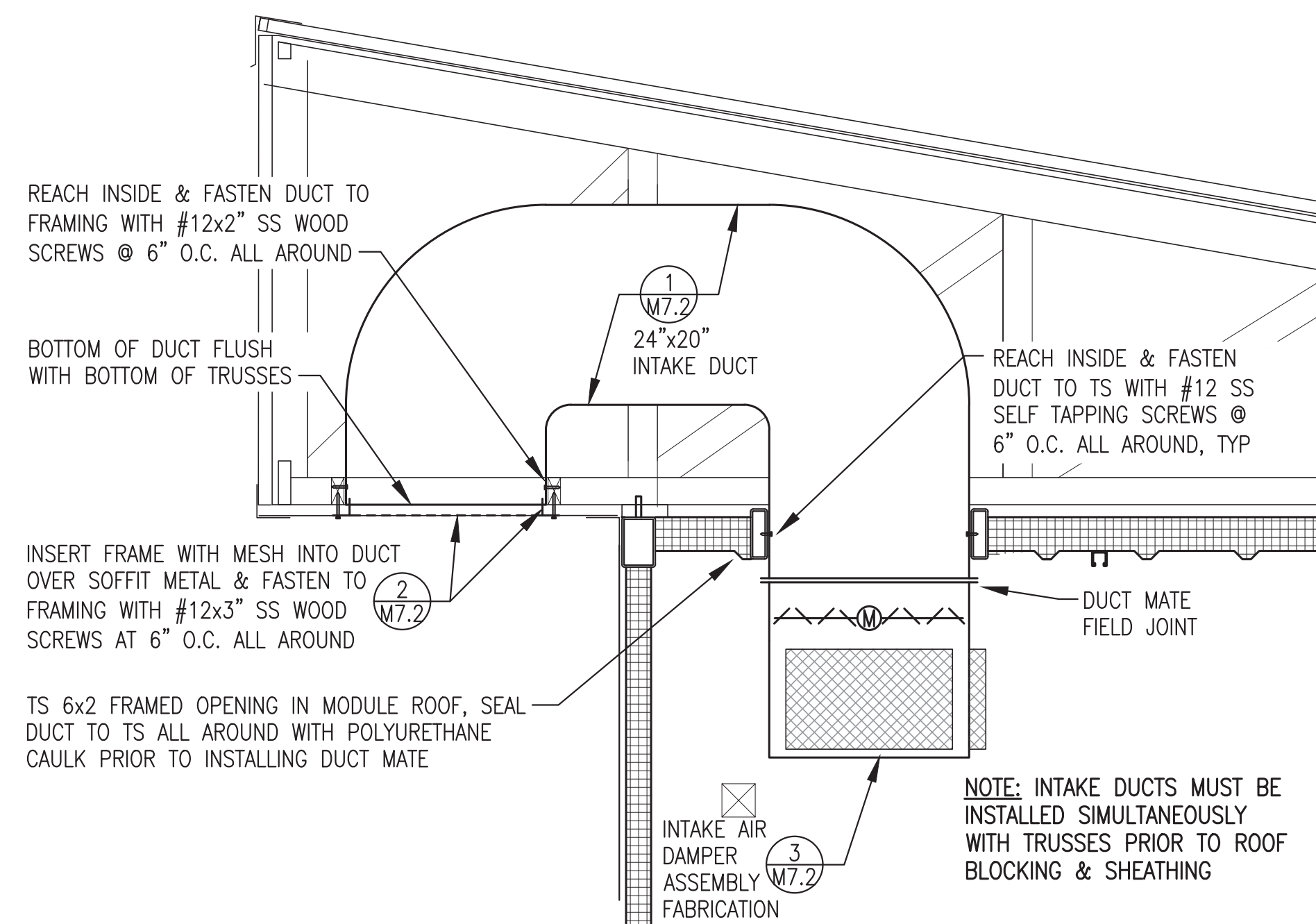

**2** INTAKE DUCT INSTALLATION  
M7.1 3/4"=1'-0"

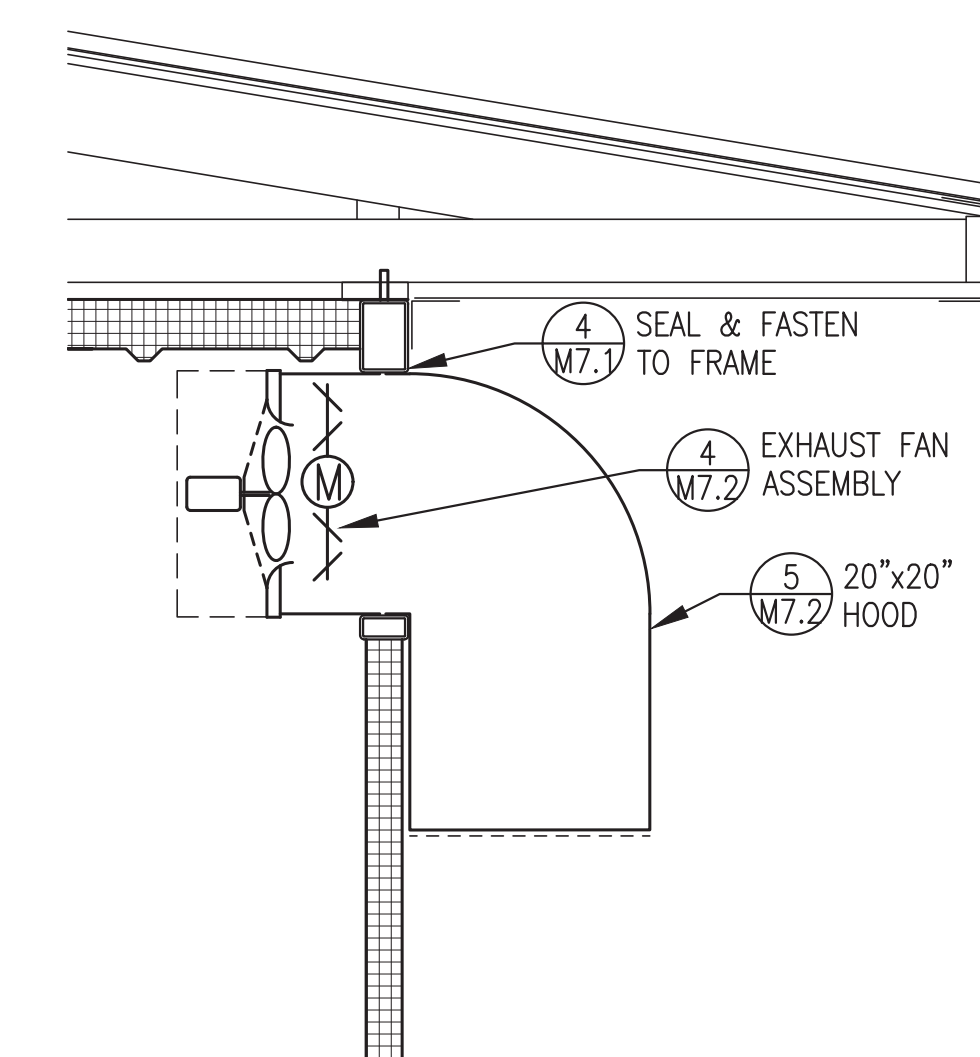

**3** EXHAUST FAN INSTALLATION  
M7.1 3/4"=1'-0"

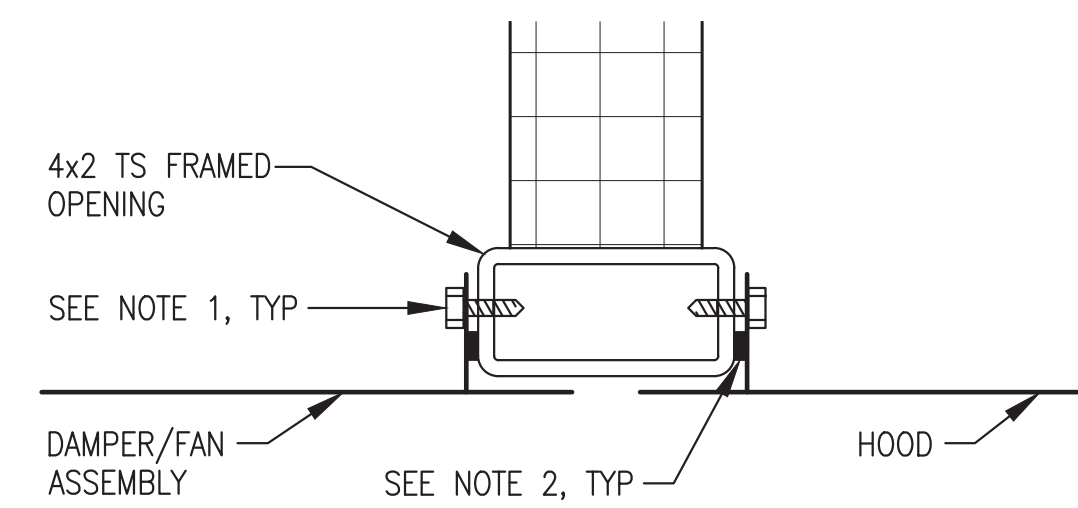

**4** TYPICAL WALL PENETRATION  
M7.1 4"=1'-0"

**VENTILATION SYSTEM SHOP/ON-SITE NOTES:**

- 1) FURNISH ENTIRE VENTILATION SYSTEM AS PART OF MODULE SHOP FABRICATION.
- 2) DURING SHOP FABRICATION INSTALL EXHAUST FAN ASSEMBLIES. TEST FIT EXTERIOR HOODS AND INTAKE DUCTS BUT DO NOT INSTALL.
- 3) DURING SHOP FABRICATION TEMPORARILY CONNECT INTAKE DAMPERS TO ELECTRICAL ROUGH IN AND TEST TO VERIFY FUNCTION. SEE SHEET E4.2.
- 4) AS PART OF ON-SITE WORK INSTALL EXHAUST HOODS AND INTAKE DUCTING AS INDICATED.

- NOTES:**
- 1) FASTEN MOUNTING FLANGE TO TS WITH #12 STAINLESS STEEL SELF TAPPING SCREWS. ON HOODS FASTEN ON TOP AND SIDES ONLY. ON EXHAUST FANS FASTEN ON SIDES ONLY.
  - 2) SEAL MOUNTING FLANGE TO TS WITH CONTINUOUS BEAD OF POLYURETHANE CAULKING ALL AROUND.

ALL WORK ON THIS SHEET WAS PERFORMED AS PART OF THE PRIOR MODULE ASSEMBLY CONTRACT EXCEPT AS SPECIFICALLY INDICATED IN THE SHOP/ON SITE NOTES.

ISSUED FOR CONSTRUCTION  
JULY 2022



ALASKA ENERGY AUTHORITY		
PROJECT: NAPASKIAK POWER SYSTEM UPGRADE		
TITLE: VENTILATION PLAN & DETAILS		
	DRAWN BY: JTD	SCALE: AS NOTED
	DESIGNED BY: BCG	DATE: 7/29/22
FILE NAME: NAPS PP M2-7	SHEET:	<b>M7.1</b>
PROJECT NUMBER:		
P.O. 111405, Anchorage, AK 99511 (907)349-0100		

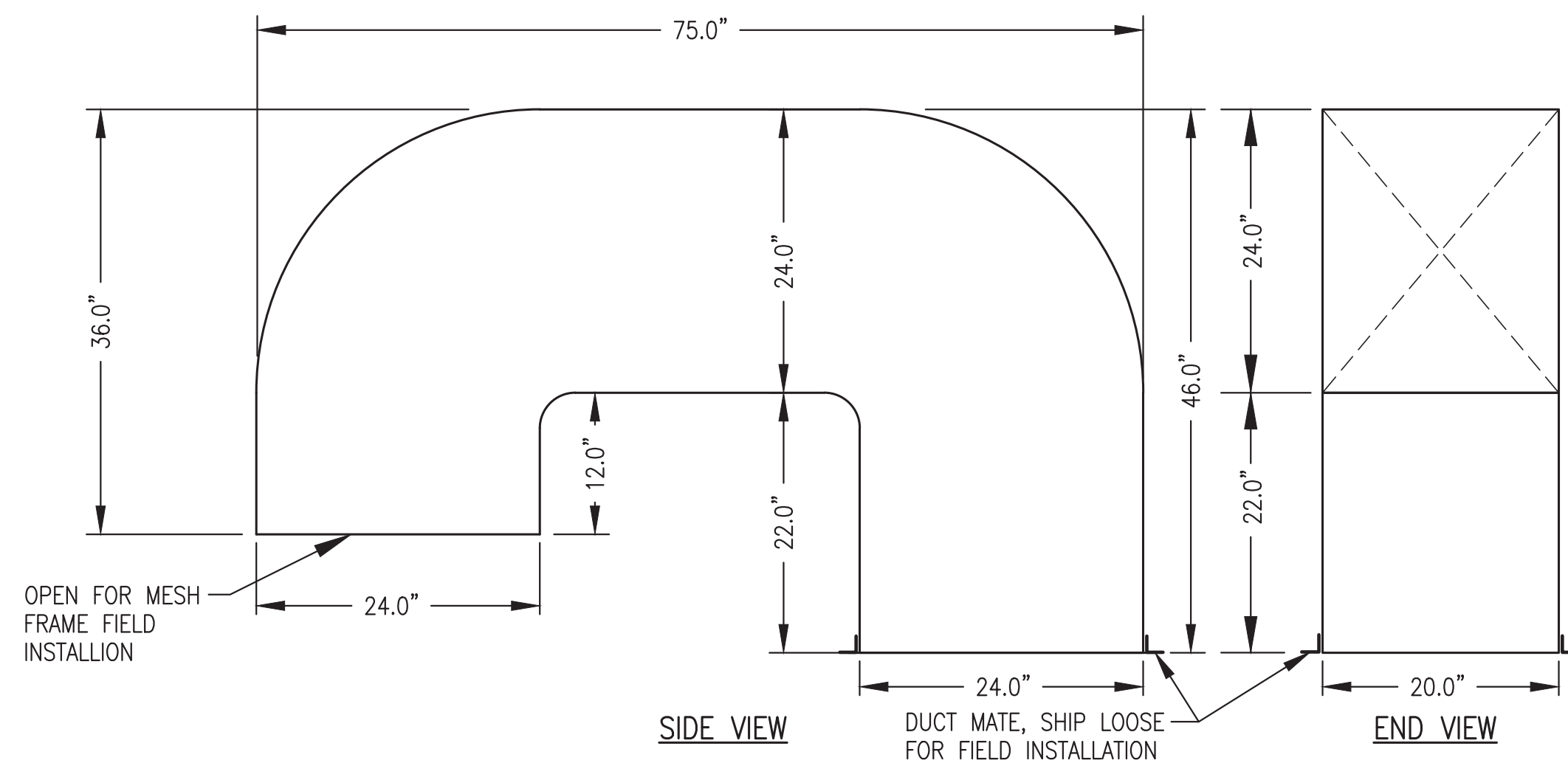

**NOTES:**

- 1) FABRICATE 4 IDENTICAL DUCTS FROM MIN 18 GAUGE GALV SHEET METAL WITH SEALED MECHANICAL JOINTS OR AT CONTRACTORS OPTION 0.090" THICK TYPE 5052 ALUMINUM WITH ALL WELDED SEAMS.
- 2) DUCTS ARE DESIGNED TO FIELD INSTALL BETWEEN TRUSSES. FABRICATE IN ONE PIECE AS INDICATED. DO NOT ADD JOINTS.

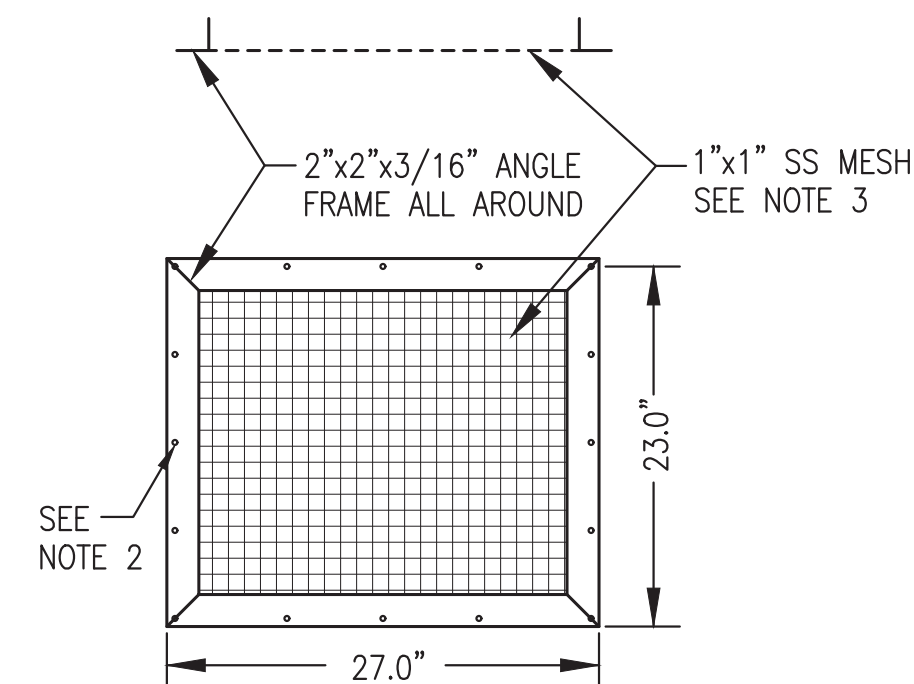

**NOTES:**

- 1) FABRICATE 3 IDENTICAL AIR INTAKE MESH FRAMES.
- 2) FABRICATE FRAME FROM 2"x2"x3/16" ALUMINUM ANGLE WITH MITERED AND WELDED CORNERS AND 1/4" HOLES AT 6" O.C. ALL AROUND, 1/2" FROM OUTSIDE EDGE OF FRAME.
- 3) INSTALL 1"x1" STAINLESS STEEL WIRE MESH IN HEMMED STAINLESS STEEL FRAME AND FASTEN TO ANGLE FRAME WITH STAINLESS STEEL SCREWS ALL AROUND.

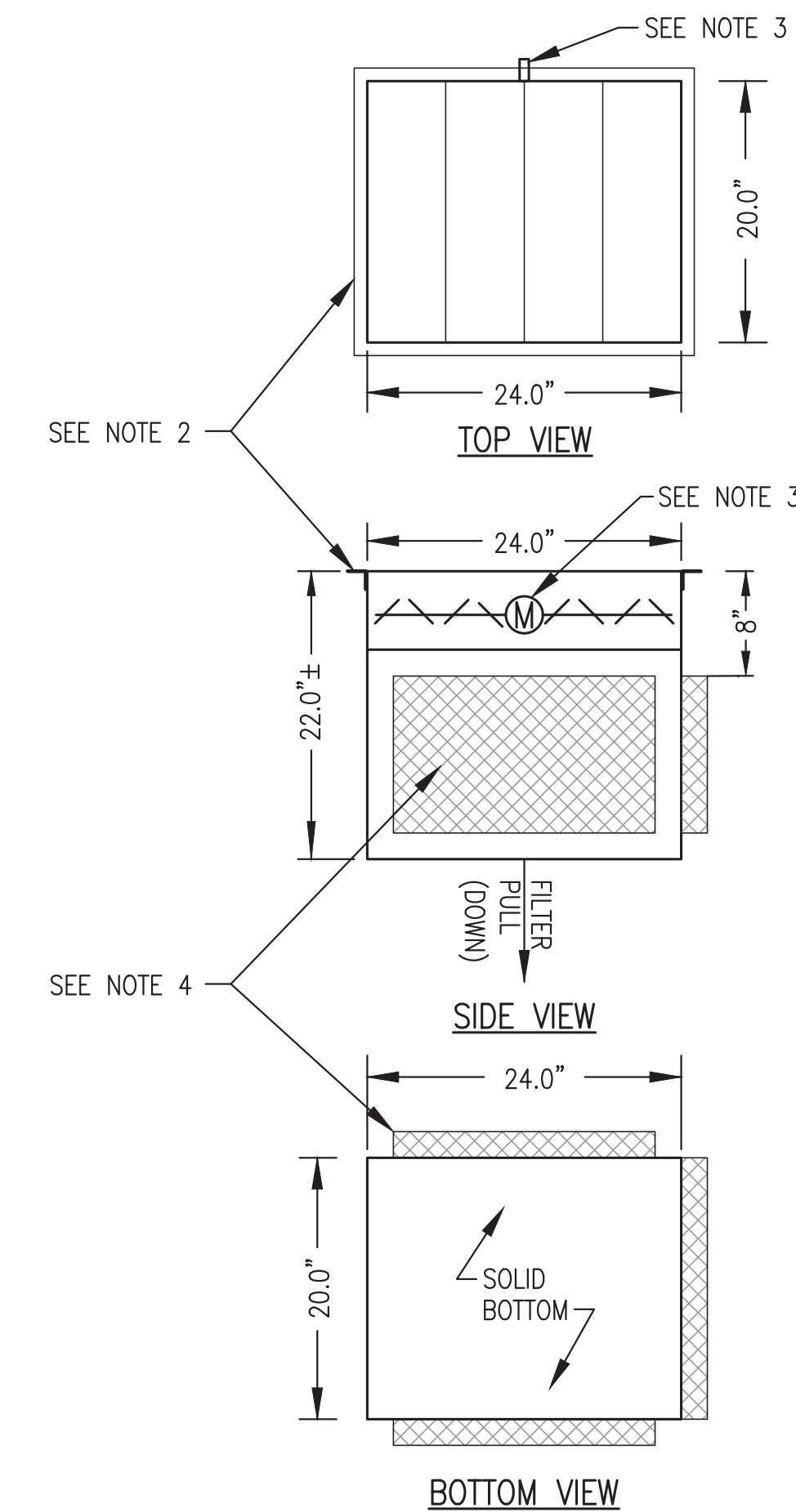

**NOTES:**

- 1) FABRICATE 4 IDENTICAL VENTILATION INTAKE ASSEMBLIES.
- 2) SHOP MOUNT DUCTMATE FLANGE.
- 3) PROVIDE MIN 3" DAMPER ROD EXTENSION ON SIDE INDICATED AND FABRICATE SHEET METAL STAND-OFF BRACKET TO FULLY SUPPORT THE ACTUATOR FROM THE DAMPER FRAME. SEE PLAN VIEW FOR DAMPER ACTUATOR ORIENTATION.
- 4) INSTALL FRAME FOR REMOVABLE 20"x12"x2" MERV 8 FILTERS. FABRICATE FROM "C" CHANNEL THREE SIDES WITH LATCHING HINGED COVER ON BOTTOM TO ALLOW FILTERS TO SLIDE DOWN FOR REMOVAL. ON 20" SIDE EXTEND FILTER FRAME BEYOND DUCT EACH WAY AS REQUIRED.

**1** INTAKE DUCT FABRICATION  
M7.2 1"=1'-0"

**2** INTAKE MESH FRAME  
M7.2 1"=1'-0"

**3** INTAKE AIR DAMPER FABRICATION  
M7.2 1"=1'-0"

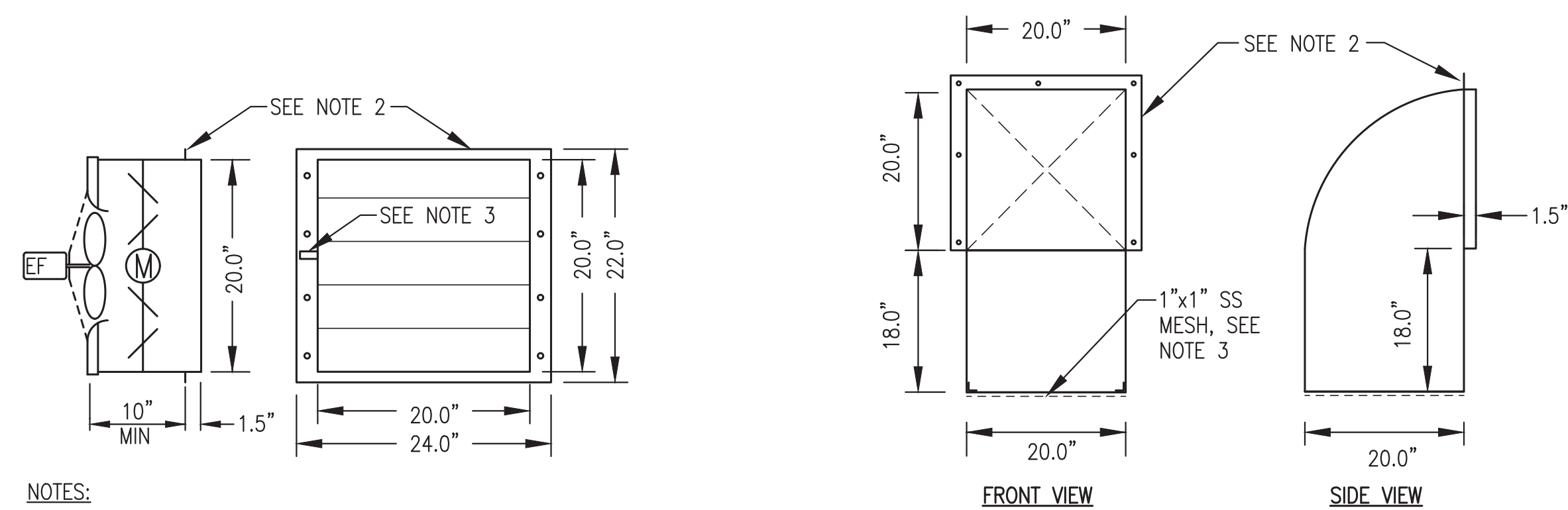

**NOTES:**

- 1) FABRICATE 3 IDENTICAL ASSEMBLIES COMPLETE WITH FAN AND DAMPER MOUNTED AND SEALED TO DUCT.
- 2) PROVIDE 2" WIDE MOUNTING FLANGE ON SIDES WITH 1/4" HOLES AT 5" O.C. PROVIDE 1" MOUNTING FLANGE ON TOP AND BOTTOM WITHOUT HOLES.
- 3) PROVIDE MIN 3" DAMPER ROD EXTENSION ON THE LEFT SIDE AND FABRICATE SHEET METAL STAND-OFF BRACKET TO FULLY SUPPORT THE ACTUATOR FROM THE DAMPER FRAME.

**NOTES:**

- 1) FABRICATE 3 IDENTICAL HOODS FROM 0.090" THICK TYPE 5052 ALUMINUM WITH ALL WELDED SEAMS.
- 2) PROVIDE 2" WIDE MOUNTING FLANGE ON TOP & SIDES WITH 1/4" HOLES AT 9" O.C.
- 3) INSTALL 1"x1" STAINLESS STEEL WIRE MESH IN HEMMED STAINLESS STEEL FRAME AND FASTEN TO ANGLE FRAME WITH STAINLESS STEEL SCREWS ALL AROUND.

**4** EXHAUST FAN ASSEMBLY FABRICATION  
M7.2 1"=1'-0"

**5** EXHAUST HOOD FABRICATION  
M7.2 3/4"=1'-0"

ALL WORK ON THIS SHEET WAS PERFORMED AS PART OF THE PRIOR MODULE ASSEMBLY CONTRACT AND IS SHOWN HERE FOR

ISSUED FOR CONSTRUCTION  
JULY 2022

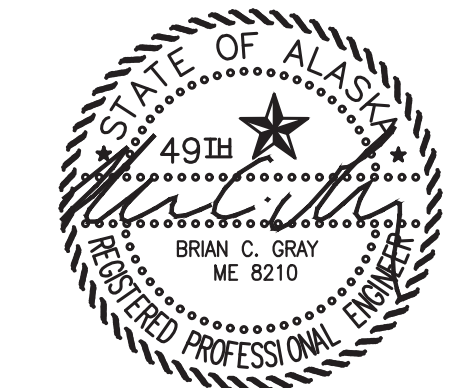

PROJECT: NAPASKIAK POWER SYSTEM UPGRADE		
TITLE: SHEET METAL FABRICATION & DETAILS		
DRAWN BY: JTD	SCALE: AS NOTED	DESIGNED BY: BCG
FILE NAME: NAPS PP M2-7	PROJECT NUMBER:	DATE: 7/29/22
P.O. 111405, Anchorage, AK 99511 (907)349-0100		SHEET: M7.2

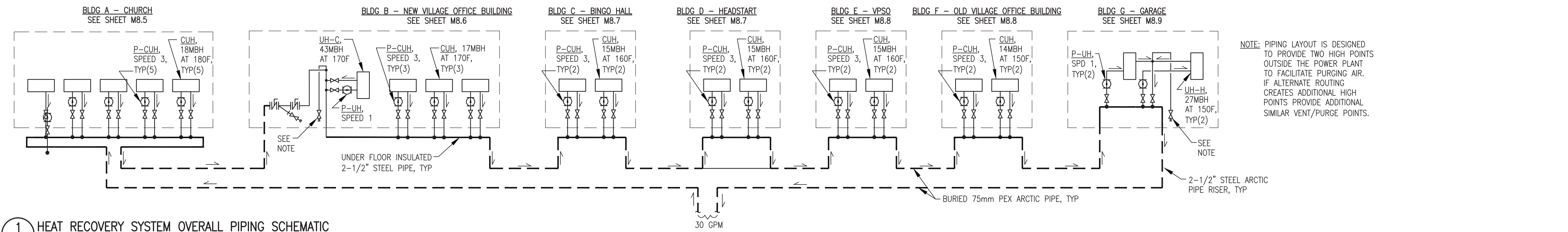

**1** HEAT RECOVERY SYSTEM OVERALL PIPING SCHEMATIC  
**M8.1** NO SCALE

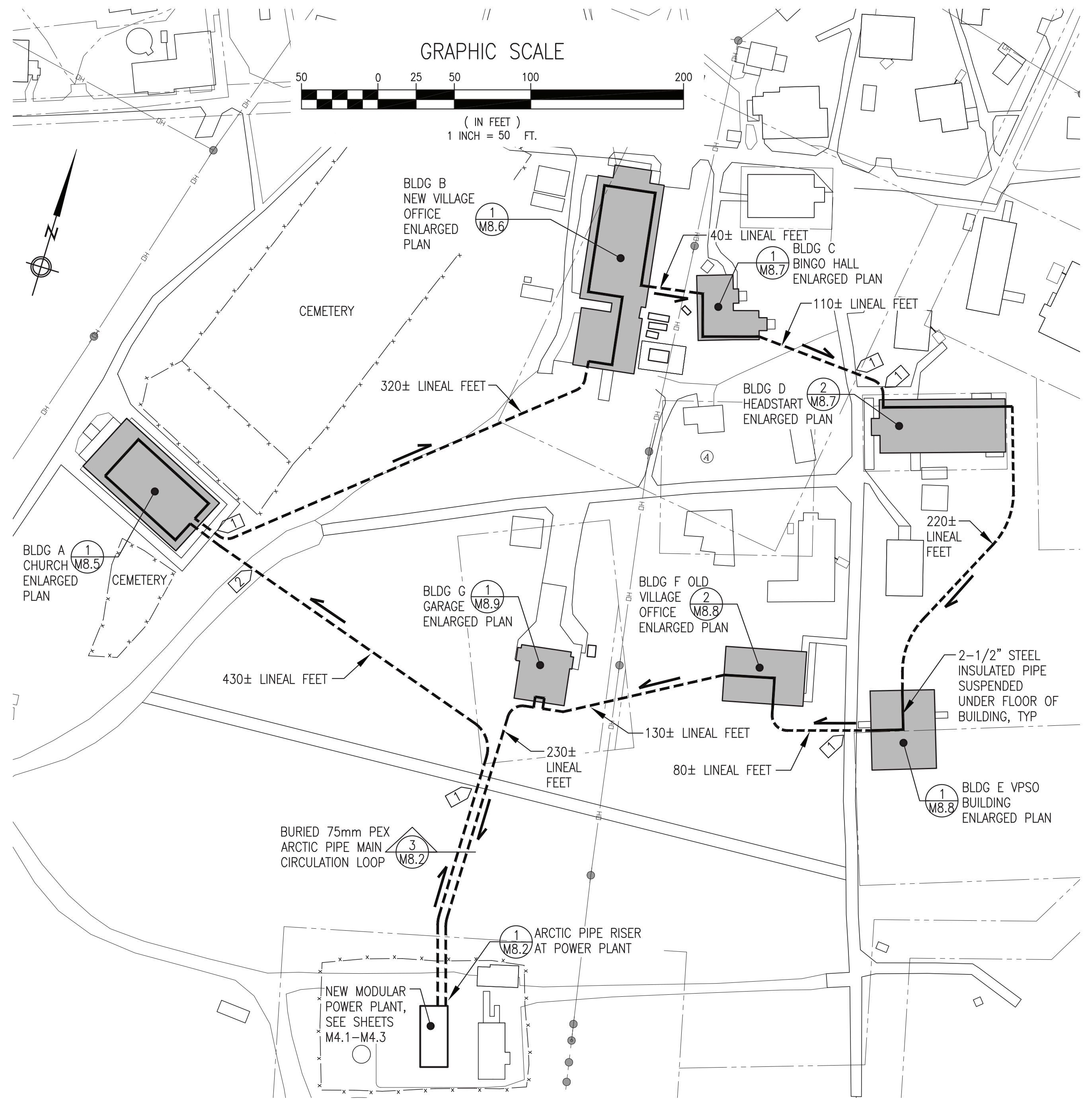

**2** HEAT RECOVERY SYSTEM OVERALL PLAN  
**M8.1** 1"=50'

**END USER BUILDING HEAT RECOVERY EQUIPMENT SCHEDULE:**

SYMBOL	SERVICE/FUNCTION	DESCRIPTION	MANUFACTURER/MODEL
CUH	OCCUPIED SPACE HEAT	WALL MOUNTED HOT WATER CABINET UNIT HEATER, 17 MBH AT 1 GPM 180F EWT & 60F EAT	TOYOTOMI HC-190 WITH WALL MOUNT BRACKET
UH-C UH-H	SHOP/STORAGE SPACE HEAT	HORIZONTAL DISCHARGE HOT WATER UNIT HEATER, 60.2 MBH AT 6.3 GPM 200F EWT AND 60F EAT, 1/12HP, 120V, 1Ø	MODINE HC-86-S-01
P-CUH	CABINET UNIT HEATER CIRC PUMP	1 GPM AT 18' TDH, 1/25HP, 115V, 1Ø. WITH 3/4" NPT SHUT OFF FLANGE & 1/2" SOLDER COMPANION FLANGE	GRUNDFOS UPS 15-58FC SPEED 3
P-UH	UNIT HEATER CIRC PUMP	5 GPM AT 4' TDH, 1/25HP, 115V, 1Ø. PROVIDE WITH 3/4" SOLDER COMPANION FLANGES	GRUNDFOS UPS 15-58FC SPEED 1

NOTE: UNIT HEATER AND CABINET UNIT HEATER RATINGS ON SCHEDULE ARE BASED ON WATER AT STANDARD TEMPERATURE. RATINGS SHOWN ON SCHEMATIC ARE REDUCED FOR 50% GLYCOL AT REDUCED TEMPERATURE.

- HEAT RECOVERY SYSTEM FILLING, FLUSHING, AND PURGING PROCEDURES:**
- AFTER PRESSURE TESTING ALL PIPING, BLEED AIR RESERVOIR ON THE EXPANSION TANK IN THE MODULE AS REQUIRED TO MAINTAIN 10 PSIG RESIDUAL WITH THE SYSTEM EMPTY.
  - AT END USER BUILDINGS, CLOSE ISOLATION VALVES AT EACH UNIT HEATER AND CABINET UNIT HEATER TO ENSURE NO FLOW THROUGH THE HEATER COILS PRIOR TO FILLING SYSTEM. VERIFY THAT THE CABINET UNIT HEATER HOSES ARE NOT CONNECTED TO HEATERS.
  - FILL THE ENTIRE HEAT RECOVERY PIPING SYSTEM WITH PROPYLENE GLYCOL SOLUTION TO 20 PSIG MINIMUM WITH SYSTEM COLD. VENT AIR FROM ALL HIGH POINT VENTS PRIOR TO STARTING CIRCULATING PUMPS. NOTE THAT HIGH POINT BLEEDS ARE LOCATED IN THE MODULE AND IN BUILDINGS B AND G.
  - CYCLE MAIN HEAT RECOVERY LOOP CIRC PUMP P-HR1B ON AND OFF AND VENT HIGH POINTS UNTIL ALL AIR HAS BEEN PURGED FROM THE MAIN PIPING LOOP. USE HOSES AND BUCKETS TO PURGE AND CAPTURE SALVAGED GLYCOL.
  - ADD PROPYLENE GLYCOL SOLUTION AS REQUIRED TO MAINTAIN 20 PSIG MINIMUM WITH SYSTEM COLD. WITH DIESEL GENERATOR(S) RUNNING, START THE HEAT RECOVERY SYSTEM PRIMARY AND SECONDARY CIRCULATION PUMPS P-HR1A AND P-HR1B. BRING THE ENTIRE HEAT RECOVERY SYSTEM UP TO NORMAL TEMPERATURE (170°F MINIMUM) AND ADD PROPYLENE GLYCOL SOLUTION AS REQUIRED TO BRING SYSTEM PRESSURE TO 30 PSIG MINIMUM AT EXPANSION TANK.
  - CIRCULATE HOT GLYCOL FOR 24 HOURS MINIMUM THEN SHUT PUMPS OFF. ISOLATE AND CLEAN PIPING STRAINERS WHICH ARE LOCATED IN THE MODULE AND IN BUILDING B. AFTER CLEANING STRAINERS OPEN STRAINER ISOLATION VALVES.
  - IN BUILDINGS B AND G USE HOSES AND BUCKETS TO PURGE AIR AND DEBRIS FROM HIGH POINT BLEEDS THEN OPEN BRANCH PIPING VALVES TO UNIT HEATERS. SET THE PUMPS TO THE SPECIFIED SPEED, OPEN THE ISOLATION VALVES, AND TURN UP THE THERMOSTAT TO START THE ASSOCIATED CIRC PUMP. CYCLE UNIT HEATER PUMPS ON AND OFF AND VENT BLEED FITTING UNTIL ALL AIR HAS BEEN PURGED AND CAPTURE SALVAGED GLYCOL.
  - GO TO EACH CABINET UNIT HEATER IN THE SYSTEM. PLACE THE CABINET UNIT HEATER HOSES IN A BUCKET AND CRACK VALVES TO PURGE AIR AND DEBRIS. BLEED A MINIMUM OF 1 GALLON FROM EACH HOSE TO ENSURE BRANCH PIPING IS COMPLETELY FLUSHED AND CAPTURE SALVAGED GLYCOL. RAISE HOSE ENDS AND CRACK VALVES TO FILL HOSES WITH FLUID THEN MAKE FINAL CONNECTION TO THE CABINET UNIT HEATERS. USING THERMOSTAT CONTROL, CYCLE CABINET UNIT HEATER PUMPS ON AND OFF AND VENT BLEED FITTINGS ON TOP OF CABINET UNIT HEATERS.
  - WHEN THE ENTIRE SYSTEM COMES UP TO NORMAL TEMPERATURE (170°F MINIMUM) ADD PROPYLENE GLYCOL SOLUTION AS REQUIRED TO BRING SYSTEM PRESSURE TO 30 PSIG MINIMUM AT EXPANSION TANK.
  - VERIFY PROPER FUNCTION OF ALL INSTRUMENTATION AND CALIBRATE ALL DEVICES. VERIFY POWER PLANT HEAT RECOVERY READINGS ON SWITCHGEAR SCADA SYSTEM.
  - GO THROUGH THE ENTIRE SYSTEM INCLUDING ALL END USER BUILDINGS AND CHECK FOR LEAKS. PERFORM FUNCTIONAL TEST OF EACH UNIT HEATER AND CABINET UNIT HEATER THERMOSTATIC CONTROLS, VERIFYING THAT FAN AND PUMP CYCLE ON AND OFF TOGETHER.
  - ADD PROPYLENE GLYCOL SOLUTION AS REQUIRED TO BRING SYSTEM PRESSURE TO 30 PSIG MINIMUM AT EXPANSION TANK. FILTER SALVAGED GLYCOL WITH 30 MICRON FILTER AND PLACE BACK IN DRUMS. STORE ALL EXCESS PROPYLENE GLYCOL SOLUTION IN THE ORIGINAL DRUMS SEALED FOR LONG-TERM STORAGE. VERIFY THAT DRUMS ARE CLEARLY LABELED "PROPYLENE GLYCOL" WITH YELLOW LETTERING.

- ARCTIC PIPE GENERAL NOTES:**
- THE DRAWINGS SHOW APPROXIMATE LOCATION OF SOME EXISTING ABOVE GRADE FEATURES. THERE ARE NO KNOWN UNDERGROUND UTILITIES. PRIOR TO BEGINNING EXCAVATION, LOCATE ALL ABOVE GRADE FEATURES AND VERIFY THERE ARE NO UNDERGROUND UTILITIES.
  - TAKE CARE TO PROTECT EXISTING BUILDING FOUNDATIONS, BOARDWALKS, AND OTHER EXISTING FEATURES WHEN EXCAVATING FOR ARCTIC PIPE. BACKFILL WITH EXCAVATION SPOILS OR SAND, COMPACT, AND BLEND INTO EXISTING GRADE. RESTORE ALL EXCAVATION AREAS TO ORIGINAL CONDITION UPON COMPLETION.
  - ANY UTILITIES DAMAGED DURING EXCAVATION SHALL BE REPAIRED PROMPTLY TO THE SATISFACTION OF THE AUTHORITY AND THE UTILITY AT NO COST TO THE AUTHORITY
  - ALL BURIED ARCTIC PIPE IS 75mm PRE-INSULATED PEX WITH PR JACKET. ALL ARCTIC PIPE RISERS AT ABOVE TO BELOW GRADE TRANSITIONS ARE WELDED 2-1/2" SCH 40 STEEL WITH POLYURETHANE INSULATION AND WATERPROOF HDPE CASING. ALL ABOVE GRADE PIPE ROUTED UNDER BUILDINGS IS WELDED 2-1/2" SCH 40 STEEL WITH FIELD INSTALLED 1-1/2" FIBERGLASS INSULATION AND ALUMINUM JACKET. SEE SPECIFICATIONS.
  - LENGTHS OF BURIED RUNS INDICATED THIS PLAN ARE APPROXIMATE, FIELD VERIFY. FURNISH 75mm PEX ARCTIC PIPE IN ADEQUATE LENGTHS TO ALLOW CONTINUOUS RUNS BETWEEN BUILDING RISERS. DO NOT INSTALL SPLICE JOINTS BETWEEN RISERS.
  - TAKE CARE TO PROTECT EXISTING BUILDING FOUNDATIONS, BOARDWALKS, AND OTHER EXISTING FEATURES WHEN EXCAVATING FOR ARCTIC PIPE. BACKFILL WITH EXCAVATION SPOILS, COMPACT, AND GRADE. RESTORE EXCAVATION AREAS TO ORIGINAL CONDITION UPON COMPLETION.
- ARCTIC PIPE SPECIFIC NOTES:**
- BURY ARCTIC PIPE UNDER EXISTING BOARDWALK. CAREFULLY DISASSEMBLE AND REMOVE SECTION OF BOARDWALK AS REQUIRED FOR TRENCHING. REINSTALL BOARDWALK TO MATCH ORIGINAL AFTER COMPLETING ARCTIC PIPE INSTALLATION.
  - BURY ARCTIC PIPE UNDER EXISTING ROAD. BACKFILL WITH CLEAN SANDY SOIL, COMPACT, AND BLEND INTO EXISTING ROAD SURFACE.

**ALL WORK ON SHEETS M8.1 THROUGH M8.9 IS INCLUDED IN THE ON SITE CONTRACT.**

**PROVIDE ENTIRE HEAT RECOVERY SYSTEM AS SHOWN ON SHEETS M8.1 THROUGH M8.9 UNDER ADDITIVE ALTERNATE #1.**

**ISSUED FOR CONSTRUCTION DECEMBER 2022**



**ALASKA ENERGY AUTHORITY**

PROJECT: **NAPASKIAK POWER SYSTEM UPGRADE**

TITLE: **HEAT RECOVERY SYSTEM OVERALL PLAN, SCHEMATIC, & EQUIPMENT SCHEDULE**

<b>Gray Stassel Engineering, Inc.</b> P.O. 111405, Anchorage, AK 99511 (907)349-0100	DRAWN BY: JTD	SCALE: AS NOTED
	DESIGNED BY: BCG	DATE: 12/15/22
	FILE NAME: NAPS PP M8	SHEET:
	PROJECT NUMBER:	<b>M8.1</b>

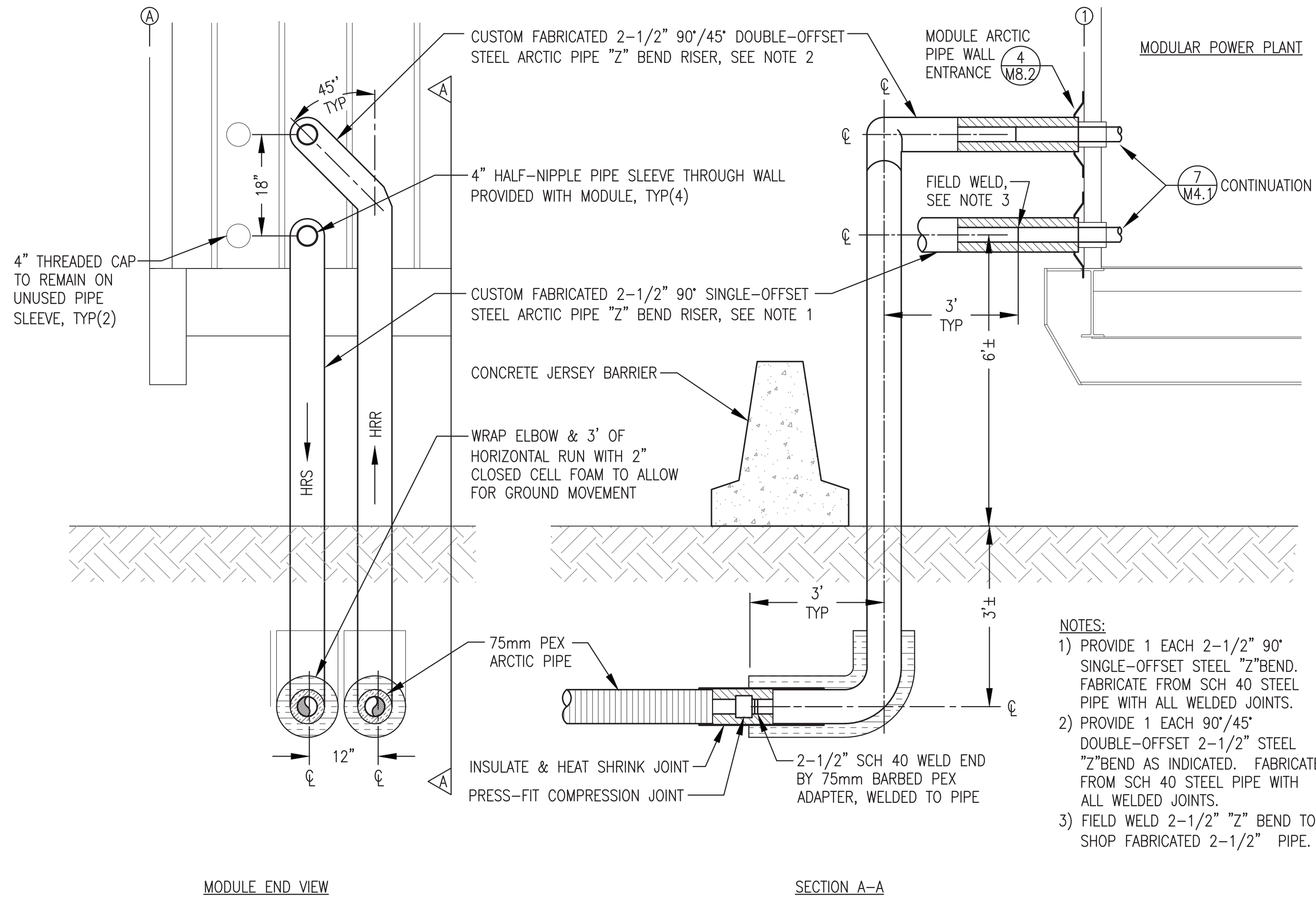

**1** ARCTIC PIPE RISER AT NEW MODULAR POWER PLANT  
 M8.2 3/4"=1'-0"

- NOTES:
- 1) PROVIDE 1 EACH 2-1/2" 90° SINGLE-OFFSET STEEL "Z" BEND. FABRICATE FROM SCH 40 STEEL PIPE WITH ALL WELDED JOINTS.
  - 2) PROVIDE 1 EACH 90°/45° DOUBLE-OFFSET 2-1/2" STEEL "Z" BEND AS INDICATED. FABRICATE FROM SCH 40 STEEL PIPE WITH ALL WELDED JOINTS.
  - 3) FIELD WELD 2-1/2" "Z" BEND TO SHOP FABRICATED 2-1/2" PIPE.

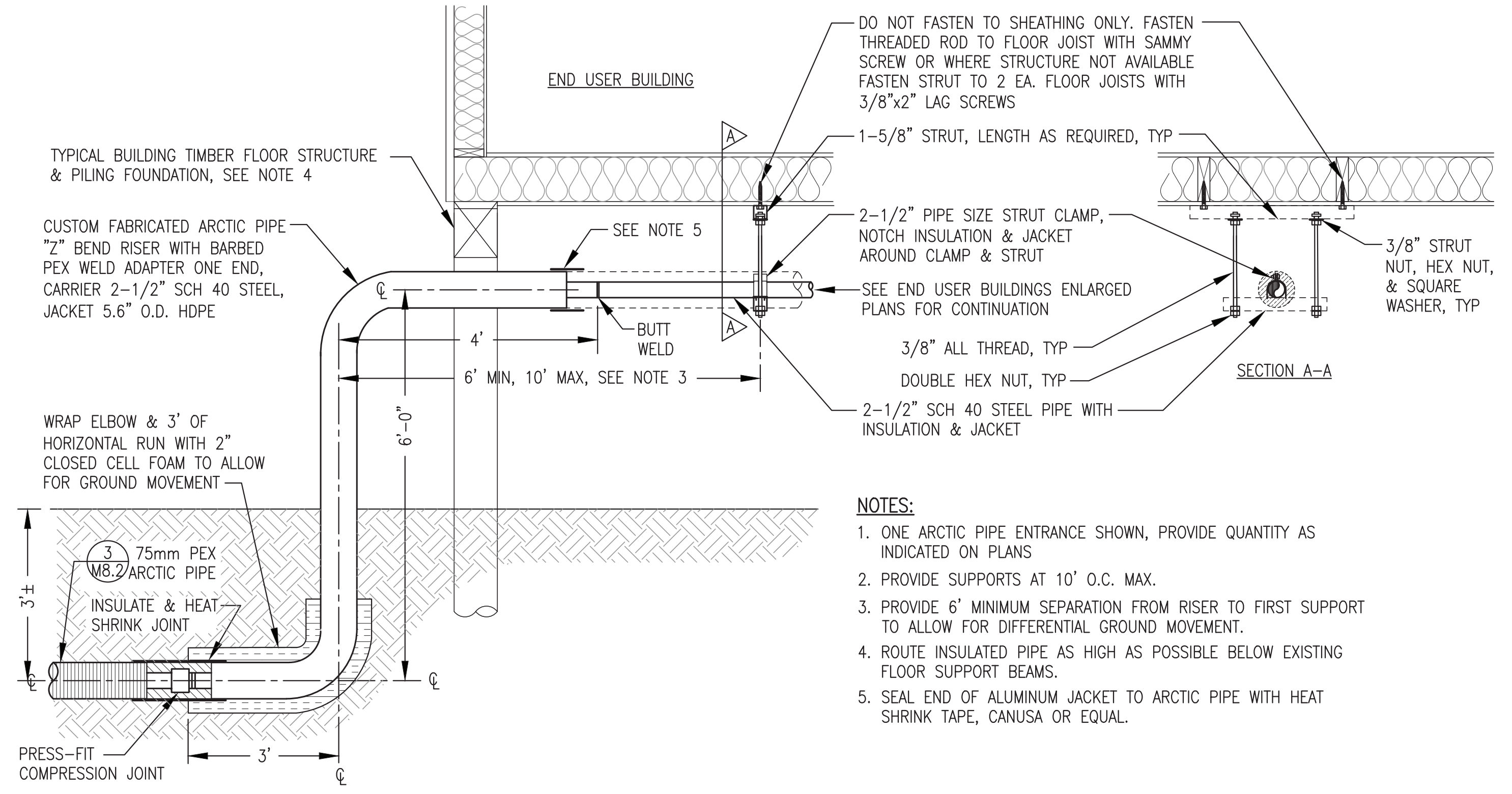

**2** TYPICAL BURIED ARCTIC PIPE RISER AND UNDER-FLOOR PIPE SUPPORT AT END USER BUILDING  
 M8.2 NO SCALE

- NOTES:
1. ONE ARCTIC PIPE ENTRANCE SHOWN, PROVIDE QUANTITY AS INDICATED ON PLANS
  2. PROVIDE SUPPORTS AT 10' O.C. MAX.
  3. PROVIDE 6' MINIMUM SEPARATION FROM RISER TO FIRST SUPPORT TO ALLOW FOR DIFFERENTIAL GROUND MOVEMENT.
  4. ROUTE INSULATED PIPE AS HIGH AS POSSIBLE BELOW EXISTING FLOOR SUPPORT BEAMS.
  5. SEAL END OF ALUMINUM JACKET TO ARCTIC PIPE WITH HEAT SHRINK TAPE, CANUSA OR EQUAL.

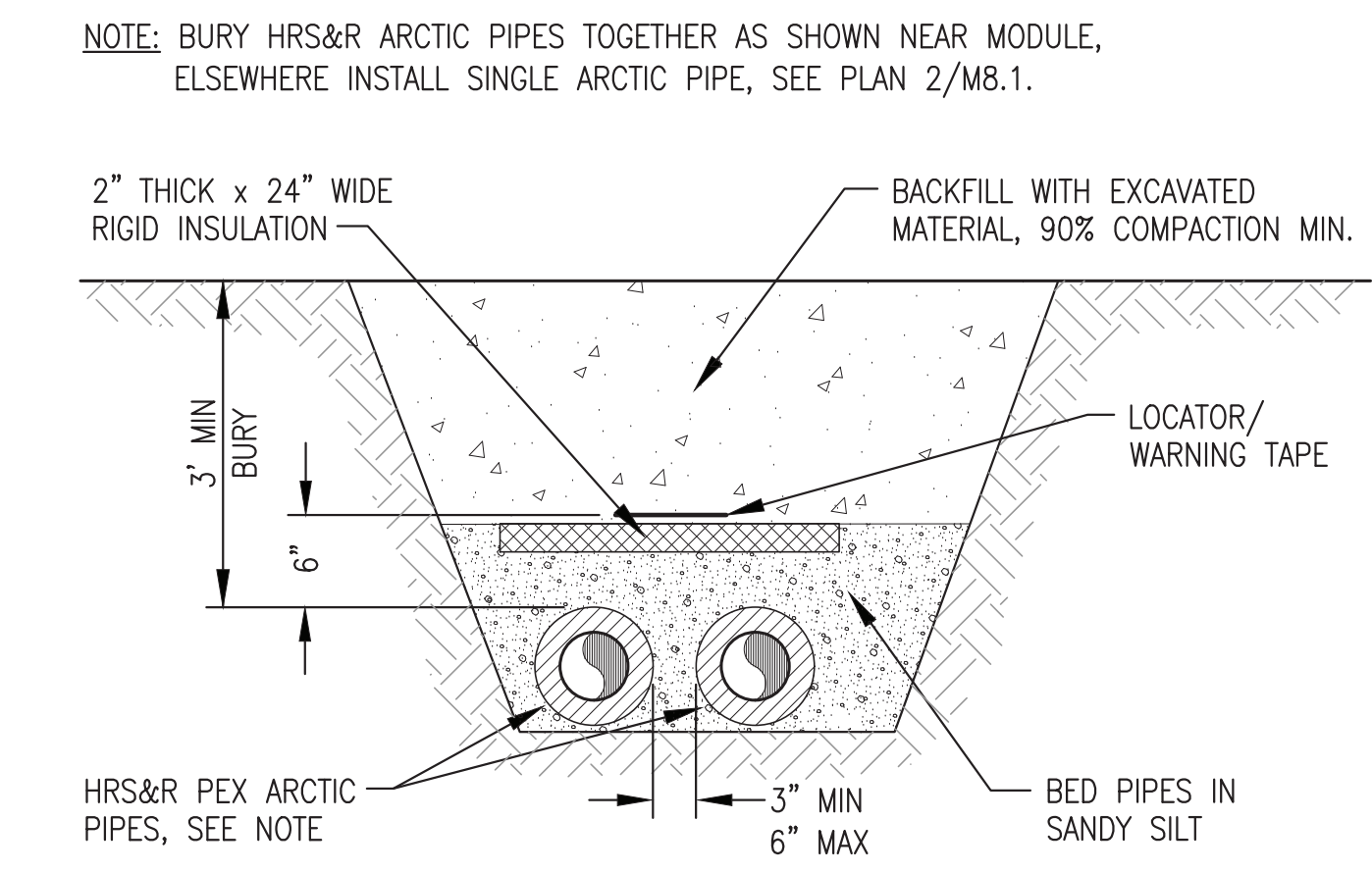

**3** TYPICAL BURIED ARCTIC PIPE INSTALLATION  
 M8.2 NO SCALE

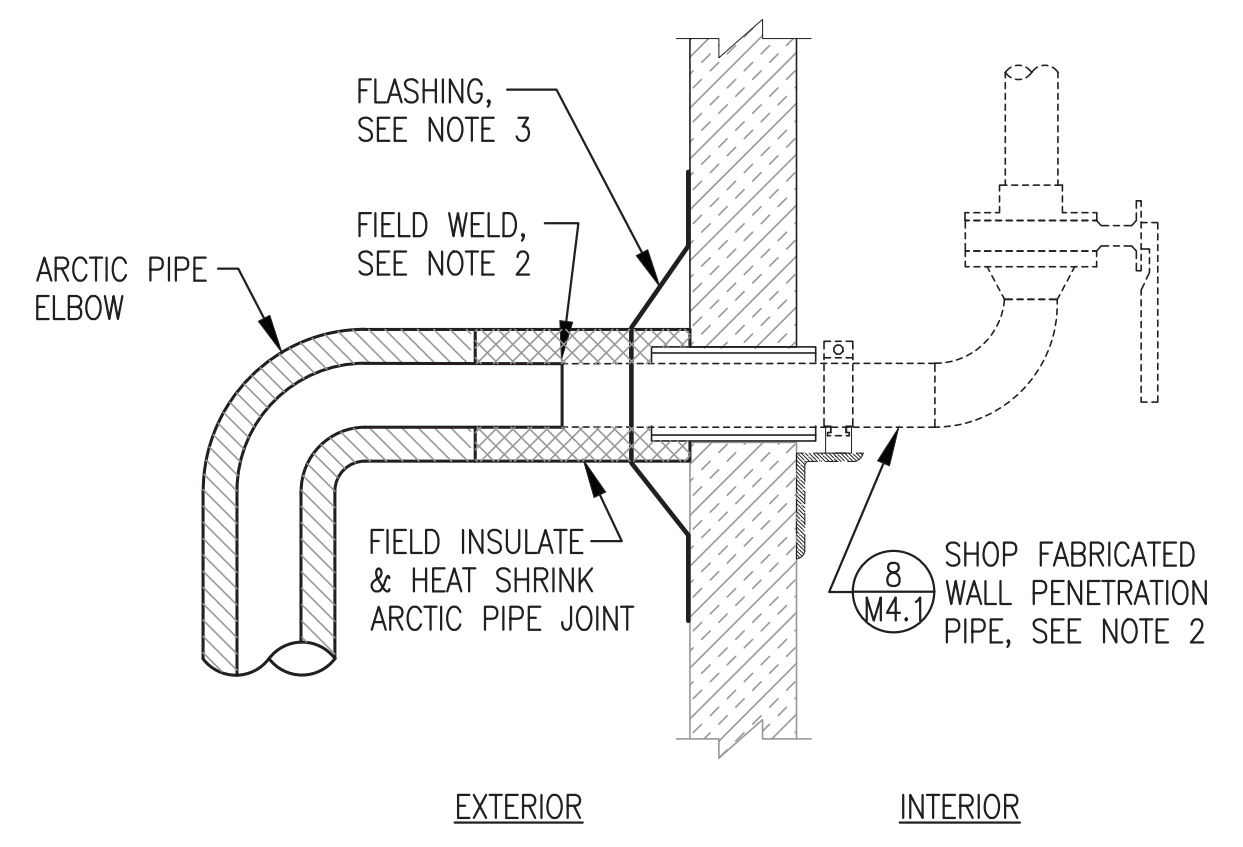

**4** ARCTIC PIPE WALL ENTRANCE AT MODULE  
 M8.2 NO SCALE

- NOTES:
- 1) ONE ARCTIC PIPE SHOWN. PROVIDE TWO SIMILAR.
  - 2) FIELD REINSTALL SHOP FABRICATED PIPE SECTION THROUGH WALL AND WELD TO ARCTIC PIPE.
  - 3) INSTALL MULTI-FLASH #5 RETROFIT MF501BA WALL FLASHING OVER ARCTIC PIPE. SEAL TO WALL SURFACE WITH POLYURETHANE CAULKING & FASTEN TO WALL WITH STAINLESS STEEL SHEET METAL SCREWS ALL AROUND.

ISSUED FOR CONSTRUCTION  
 DECEMBER 2022



PROJECT: NAPASKIAK POWER SYSTEM UPGRADE	
TITLE: HEAT RECOVERY SYSTEM ARCTIC PIPE DETAILS	
DESIGNED BY: BCG	SCALE: AS NOTED
FILE NAME: NAPS PP M8	DATE: 12/15/22
PROJECT NUMBER:	SHEET: M8.2
P.O. 111405, Anchorage, AK 99511 (907)349-0100	



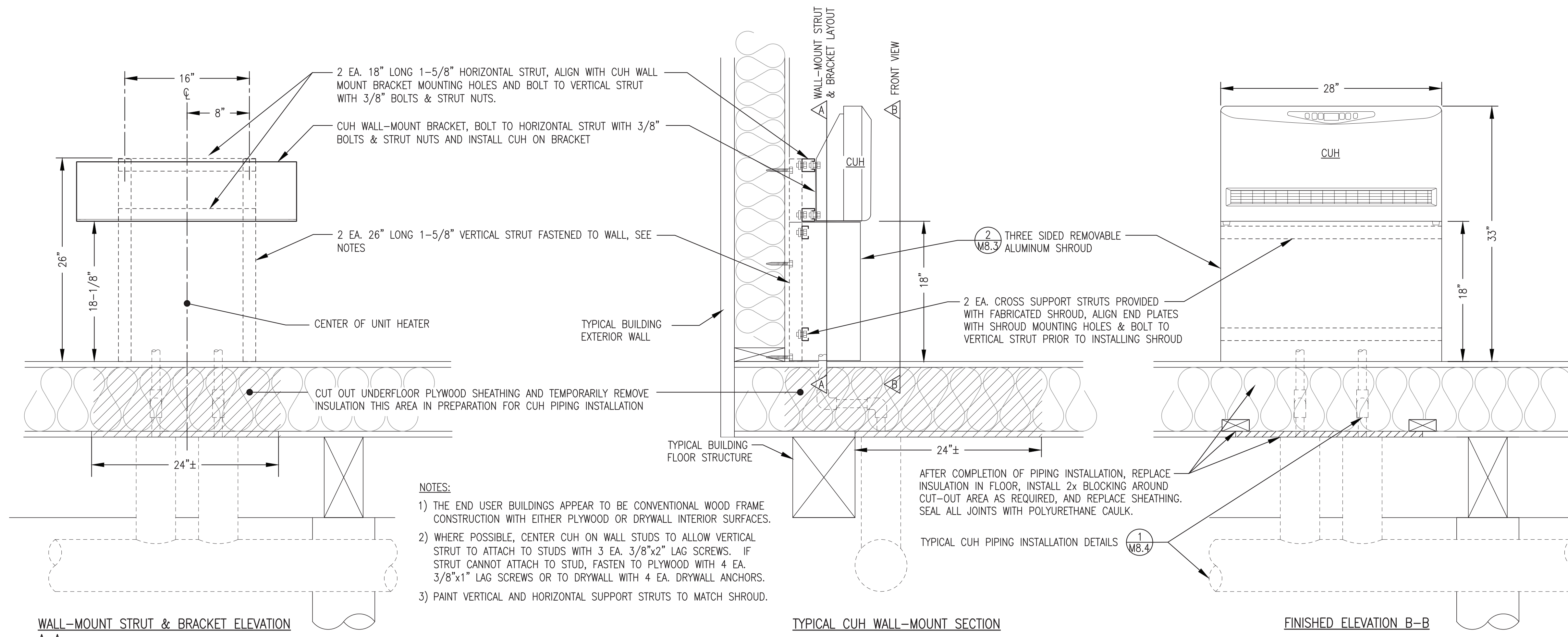

- NOTES:**
- 1) THE END USER BUILDINGS APPEAR TO BE CONVENTIONAL WOOD FRAME CONSTRUCTION WITH EITHER PLYWOOD OR DRYWALL INTERIOR SURFACES.
  - 2) WHERE POSSIBLE, CENTER CUH ON WALL STUDS TO ALLOW VERTICAL STRUT TO ATTACH TO STUDS WITH 3 EA. 3/8"x2" LAG SCREWS. IF STRUT CANNOT ATTACH TO STUD, FASTEN TO PLYWOOD WITH 4 EA. 3/8"x1" LAG SCREWS OR TO DRYWALL WITH 4 EA. DRYWALL ANCHORS.
  - 3) PAINT VERTICAL AND HORIZONTAL SUPPORT STRUTS TO MATCH SHROUD.

AFTER COMPLETION OF PIPING INSTALLATION, REPLACE INSULATION IN FLOOR, INSTALL 2x BLOCKING AROUND CUT-OUT AREA AS REQUIRED, AND REPLACE SHEATHING. SEAL ALL JOINTS WITH POLYURETHANE CAULK.

**1** TYPICAL END USER BUILDING CABINET UNIT HEATER (CUH) & SHROUD WALL-MOUNT INSTALLATION  
 M8.3 NO SCALE

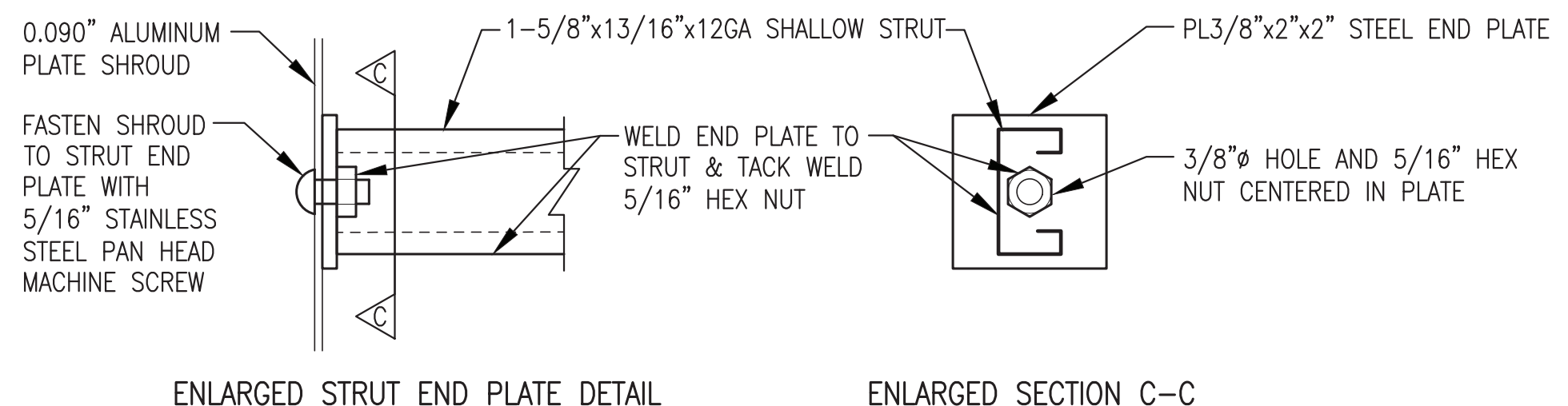
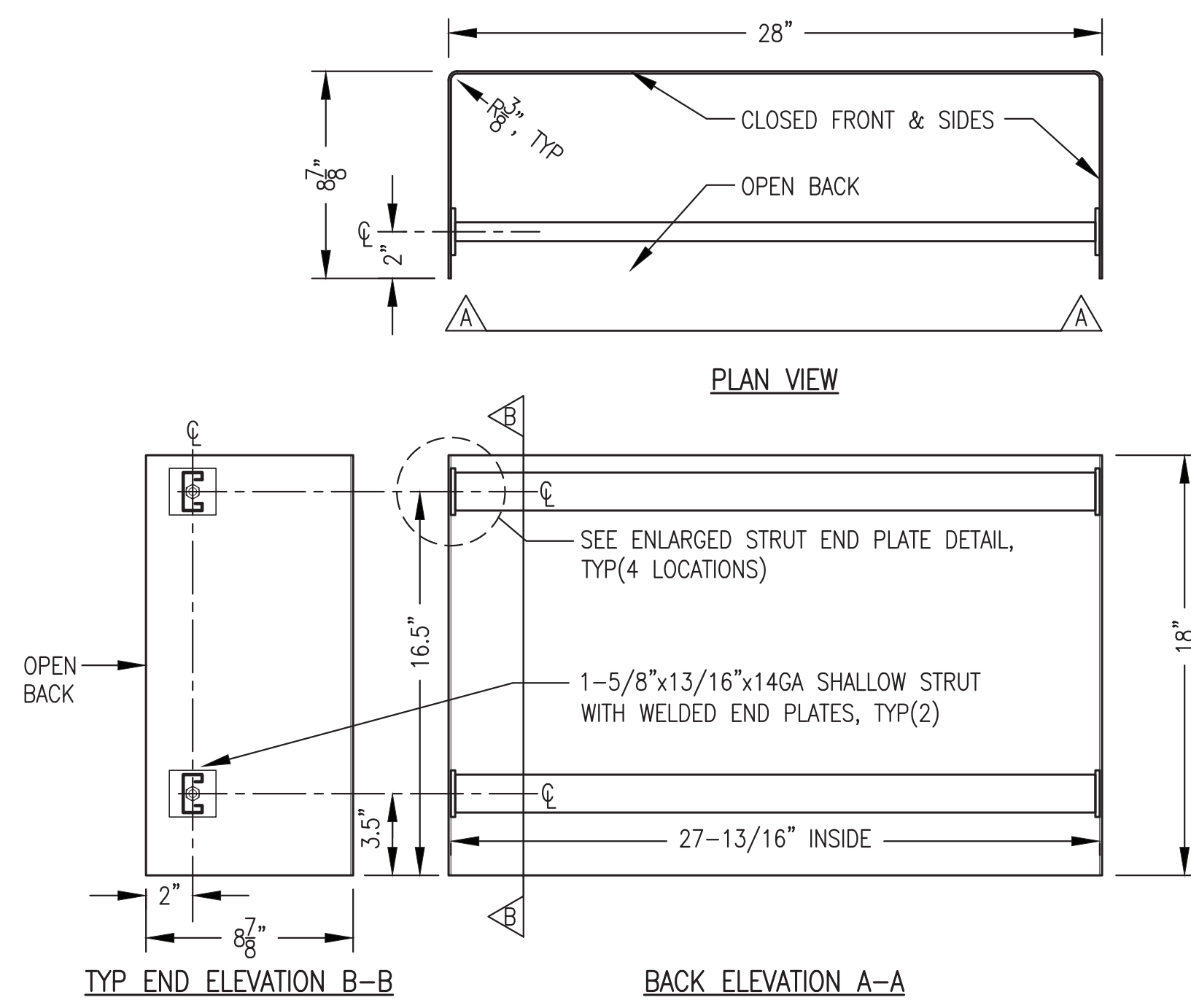

- NOTES:**
1. FABRICATE 3-SIDED SHROUD WITH OPEN TOP, BOTTOM, AND BACK FROM 0.090" 5052-H32 MILL FINISH ALUMINUM PLATE.
  2. UPON COMPLETION OF SHROUD FABRICATION ROUND ALL OUTSIDE CORNERS AND GRIND ALL EDGES SMOOTH. PREPARE AND PAINT ALL EXTERIOR SURFACES WITH TWO COATS OF ALKYD ENAMEL, COLOR TO MATCH CUH.
  3. UPON COMPLETION OF STRUT END PLATE FABRICATION, WIRE BRUSH ALL WELD AREAS AND BARE STEEL AND PAINT WITH ONE COAT OF COLD GALVANIZING COMPOUND.
  4. PROVIDE ALL FASTENERS AND HARDWARE AS INDICATED THIS DETAIL AND ATTACH CROSS STRUTS TO SHROUD FOR SHIPPING.

**2** TYPICAL CUH ALUMINUM SHROUD FABRICATION DETAIL  
 M8.3 2"=1'-0"

ISSUED FOR CONSTRUCTION  
 DECEMBER 2022



ALASKA ENERGY AUTHORITY	
PROJECT:	NAPASKIAK POWER SYSTEM UPGRADE
TITLE:	HEAT RECOVERY SYSTEM TYPICAL CUH WALL-MOUNT DETAILS
DRAWN BY: JTD	SCALE: AS NOTED
DESIGNED BY: BCG	DATE: 12/15/22
FILE NAME: NAPS PP M8	SHEET:
PROJECT NUMBER:	<b>M8.3</b>
P.O. 111405, Anchorage, AK 99511 (907)349-0100	

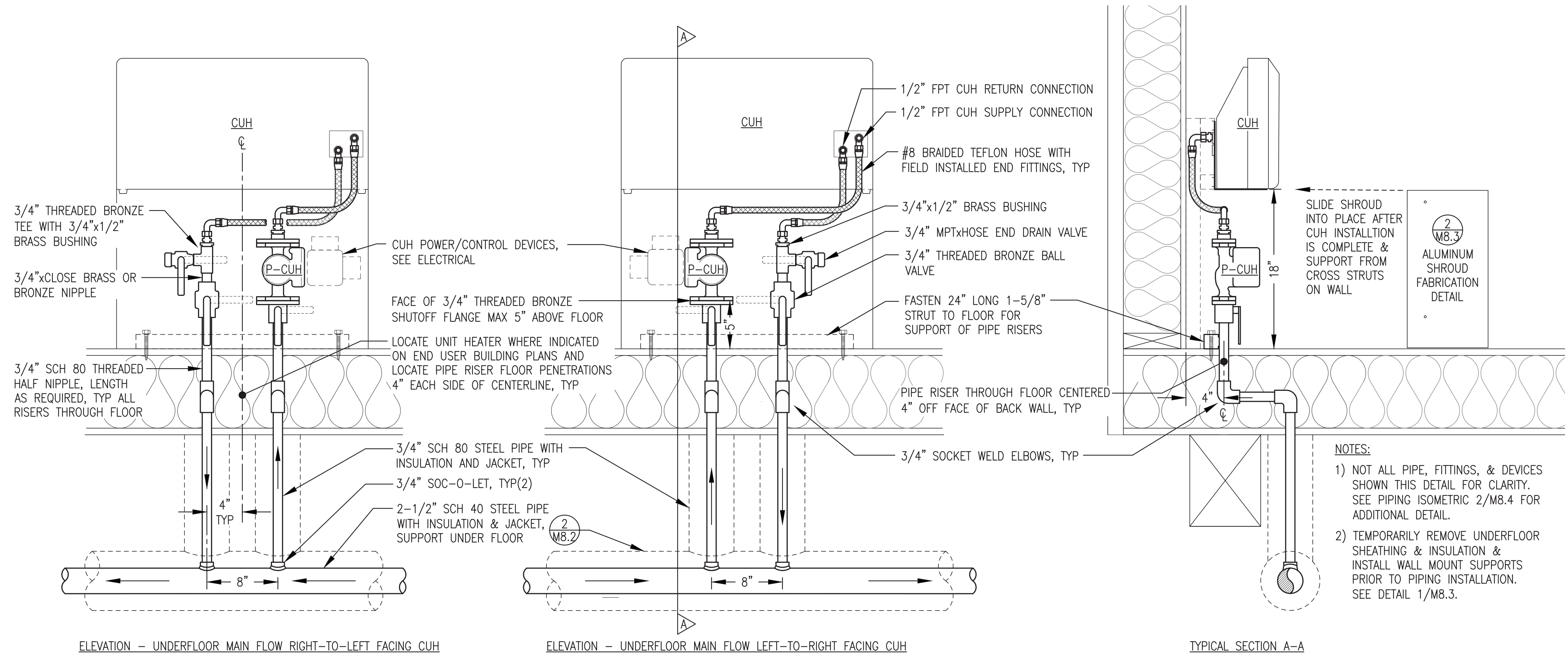

- NOTES:**
- 1) NOT ALL PIPE, FITTINGS, & DEVICES SHOWN THIS DETAIL FOR CLARITY. SEE PIPING ISOMETRIC 2/M8.4 FOR ADDITIONAL DETAIL.
  - 2) TEMPORARILY REMOVE UNDERFLOOR SHEATHING & INSULATION & INSTALL WALL MOUNT SUPPORTS PRIOR TO PIPING INSTALLATION. SEE DETAIL 1/M8.3.

**1**  
**M8.4** TYPICAL END USER BUILDING CABINET UNIT HEATER (CUH) PIPING INSTALLATION DETAIL  
NO SCALE

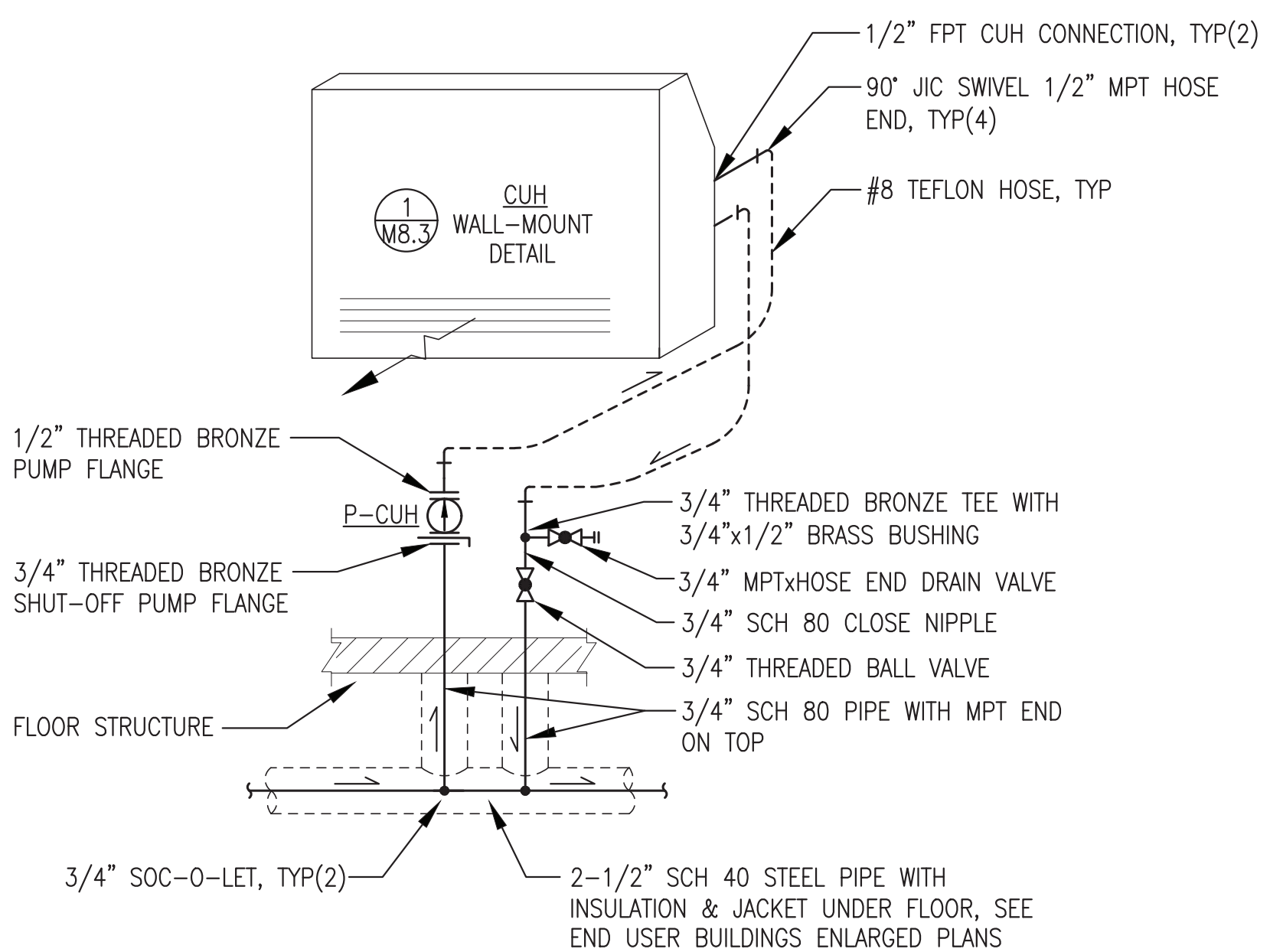

- END USER CUH PIPING ISOMETRIC NOTES:**
- 1) INSTALLATION FOR CUH WITH UNDER FLOOR SUPPLY MAIN FLOW FROM LEFT TO RIGHT SHOWN THIS ISOMETRIC. PIPING FOR CUH WITH SUPPLY MAIN FLOW FROM RIGHT TO LEFT REQUIRES MIRRORED PIPING LAYOUT. SEE DETAIL 1/M8.4 FOR BOTH PIPING LAYOUTS.
  - 2) ALL PIPING SHOWN THIS ISOMETRIC IS STEEL WITH WELDED JOINTS EXCEPT WHERE SPECIFICALLY INDICATED AS THREADED, 2-1/2" SCH 40, 3/4" SCH 80.
  - 3) PROVIDE PUMP SUCTION AND DISCHARGE FLANGES AS SPECIFICALLY INDICATED.
  - 4) ALL HOSES TEFLON (TFPE) HOSE WITH STAINLESS STEEL OUTER BRAID, EATON WEATHERHEAD H243 OR EQUAL. PROVIDE STEEL JIC SWIVEL ENDS WITH 1/2" NPT ADAPTERS. PROVIDE HOSE TO MATCH CONNECTION SIZES. PROVIDE LENGTHS AS APPROPRIATE FOR EACH INSTALLATION WITHOUT EXTRA LOOPS OR COILS. SEE SPECIFICATIONS.
  - 5) ALL UNDERFLOOR PIPING INSULATED. ALL INTERIOR PIPING NOT INSULATED. ALL PIPING NOT PAINTED.
  - 6) SEAL ALL EXTERIOR PIPE FLOOR PENETRATIONS. SEE DETAIL 1/M8.3.
  - 7) ALL VALVES NORMALLY OPEN EXCEPT FOR DRAIN VALVES.
  - 8) CLOSE ISOLATION VALVES AND DO NOT CONNECT TO CUH UNTIL AFTER PIPING MAINS HAVE BEEN FLUSHED. CRACK VALVES TO FLUSH AND PURGE BRANCH PIPING AND HOSES THEN MAKE FINAL CONNECTIONS. SEE NOTES SHEET M8.1.
  - 9) SET PUMP TO OPERATE AT SPEED 3.

**2**  
**M8.4** TYPICAL END USER BUILDING CABINET UNIT HEATER (CUH) PIPING ISOMETRIC  
NO SCALE

ISSUED FOR  
CONSTRUCTION  
DECEMBER 2022

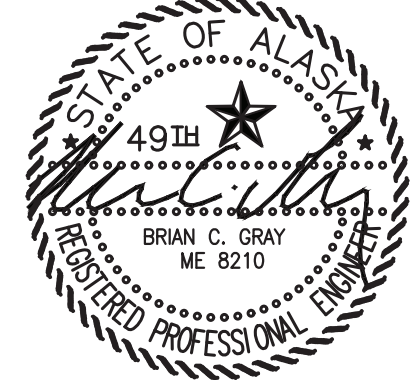

ALASKA ENERGY AUTHORITY		
PROJECT: NAPASKIAK POWER SYSTEM UPGRADE		
TITLE: HEAT RECOVERY SYSTEM TYPICAL CUH PIPING INSTALLATION DETAILS		
	DRAWN BY: JTD DESIGNED BY: BCG FILE NAME: NAPS PP M8 PROJECT NUMBER:	SCALE: AS NOTED DATE: 12/15/22 SHEET: <b>M8.4</b>
P.O. 111405, Anchorage, AK 99511 (907)349-0100		

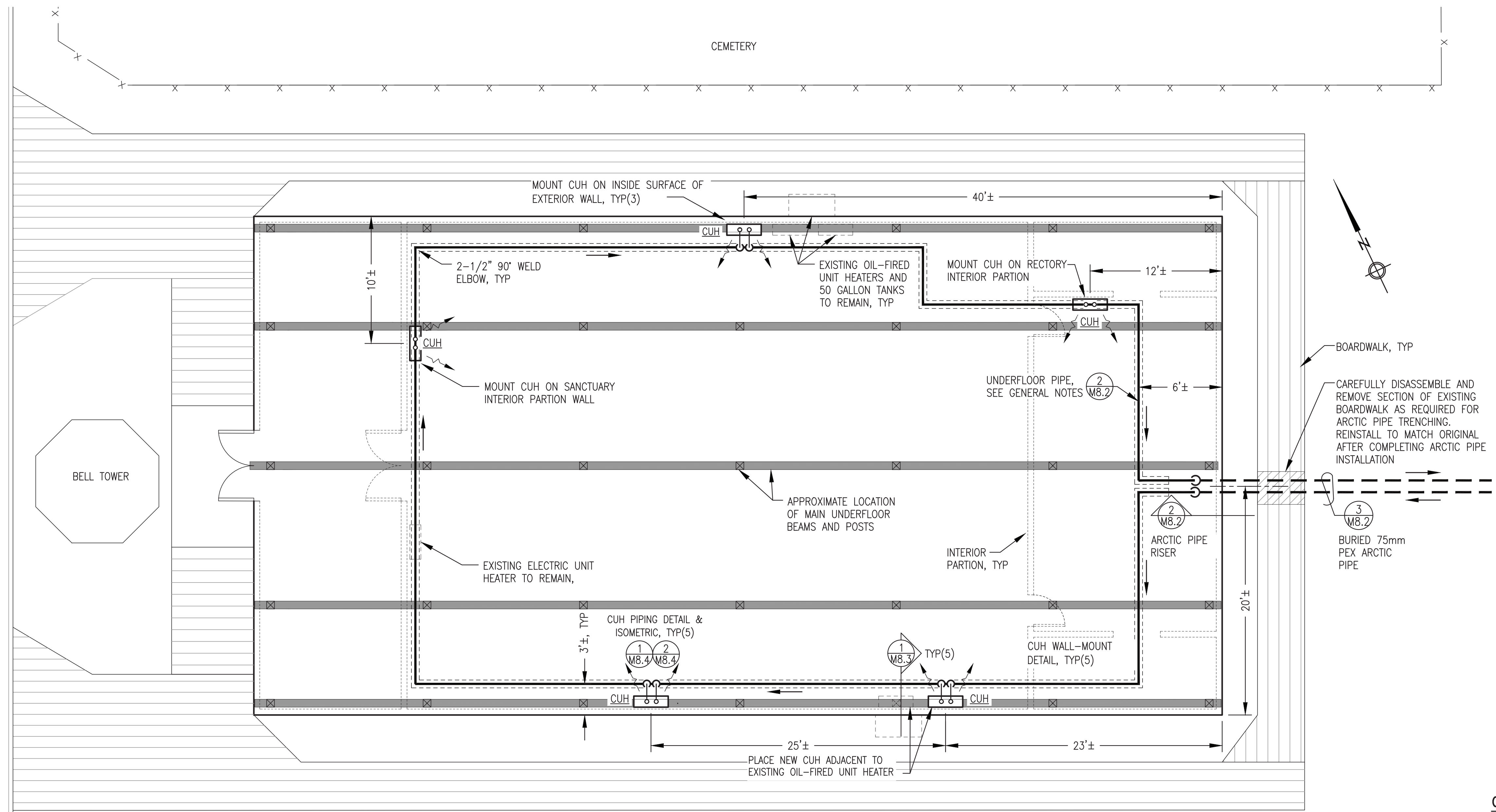

- GENERAL NOTES:**
- 1) ALL UNDERFLOOR PIPING TO BE 2-1/2" SCH 40 STEEL PIPE WITH INSULATION AND JACKET, SEE SPECIFICATIONS.
  - 2) UNDERFLOOR PIPING DIMENSIONS ARE APPROXIMATE, FIELD ROUTE AS REQUIRED TO ALIGN BELOW CUH LOCATIONS AND TO CLEAR ALL SUPPORT STRUCTURES AND OTHER UNDERFLOOR UTILITIES.
  - 3) SEE OVERALL PLAN SHEET M8.1 FOR CONTINUATION OF BURIED HEAT RECOVERY MAINS.

1 BUILDING A RUSSIAN OTHODOX CHURCH ENLARGED UNDERFLOOR PIPING PLAN  
 M8.5 3/16"=1'-0"

ISSUED FOR  
 CONSTRUCTION  
 DECEMBER 2022

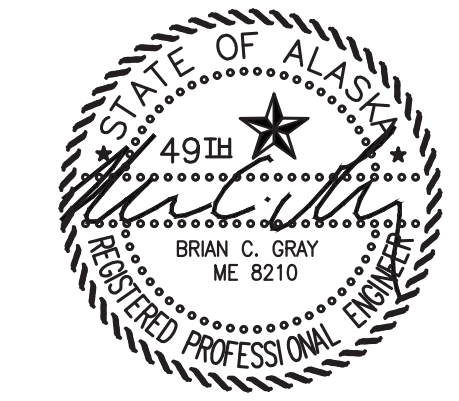

ALASKA ENERGY AUTHORITY	
PROJECT: NAPASKIAK POWER SYSTEM UPGRADE	
TITLE: HEAT RECOVERY SYSTEM BUILDING A ENLARGED PLANS & DETAILS	
DRAWN BY: JTD	SCALE: AS NOTED
DESIGNED BY: BCG	DATE: 12/15/22
FILE NAME: NAPS PP M8	SHEET:
P.O. 111405, Anchorage, AK 99511 (907)349-0100	<b>M8.5</b>

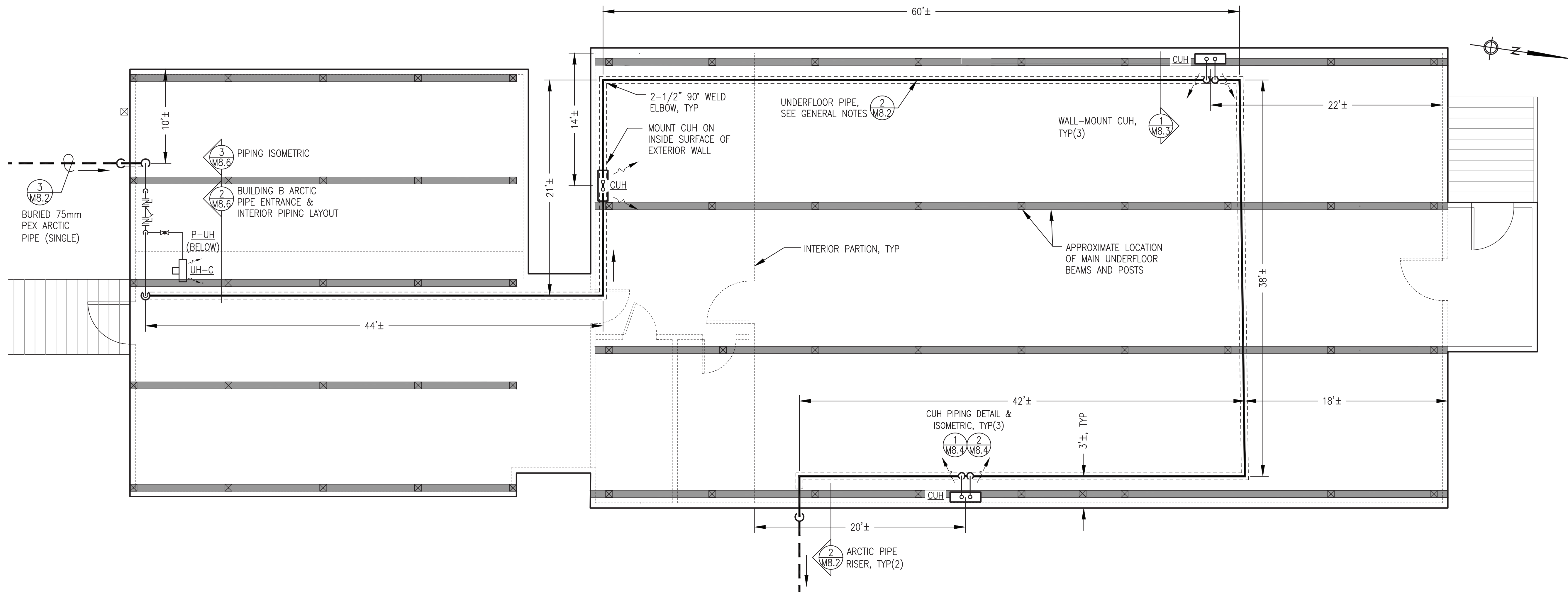

**1** BUILDING B NEW OFFICE BUILDING ENLARGED UNDERFLOOR PIPING PLAN  
**M8.6** 3/16"=1'-0"

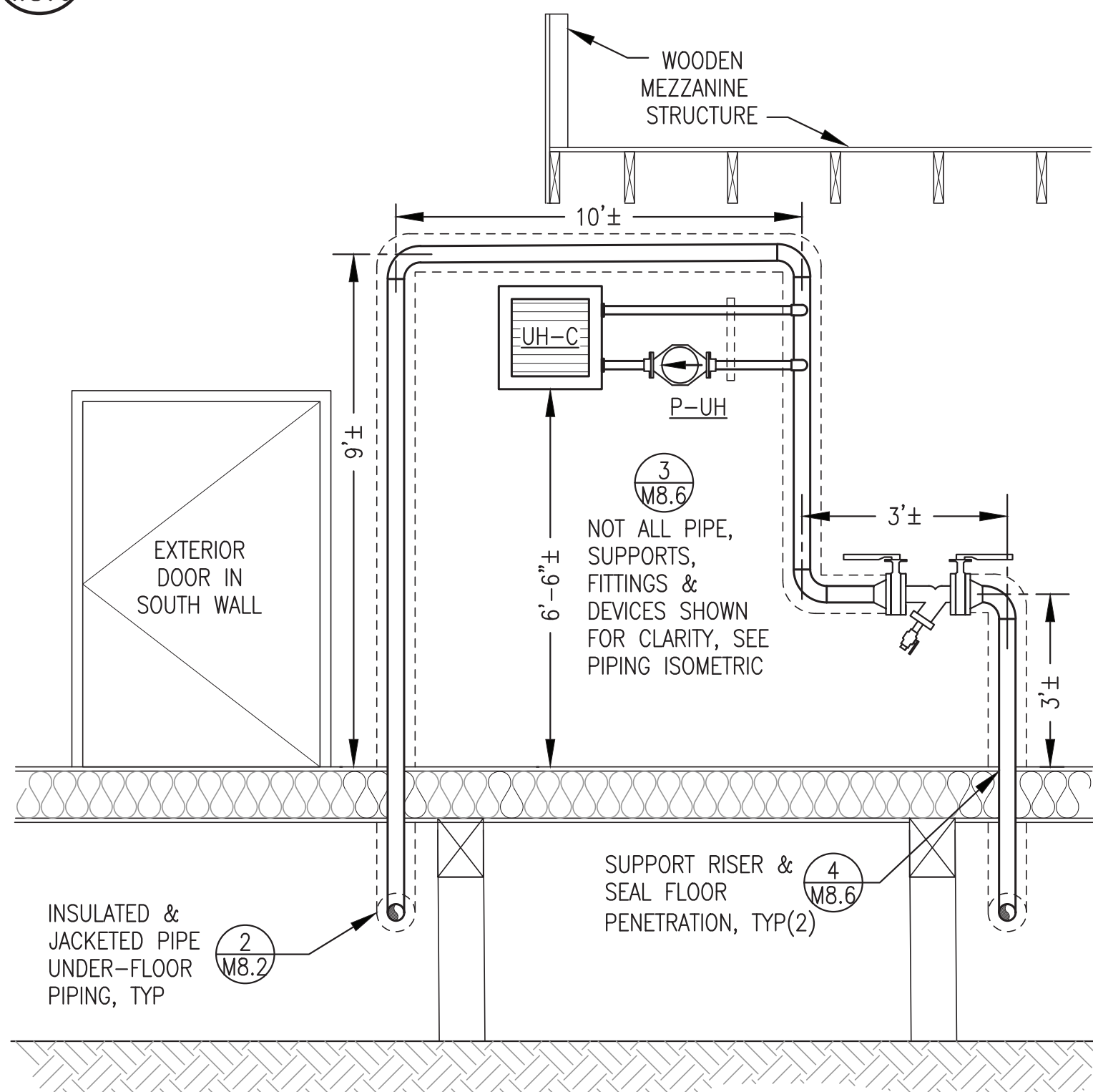

**2** BUILDING B ARCTIC PIPE ENTRANCE AND UH-C PIPING LAYOUT  
**M8.6** NO SCALE

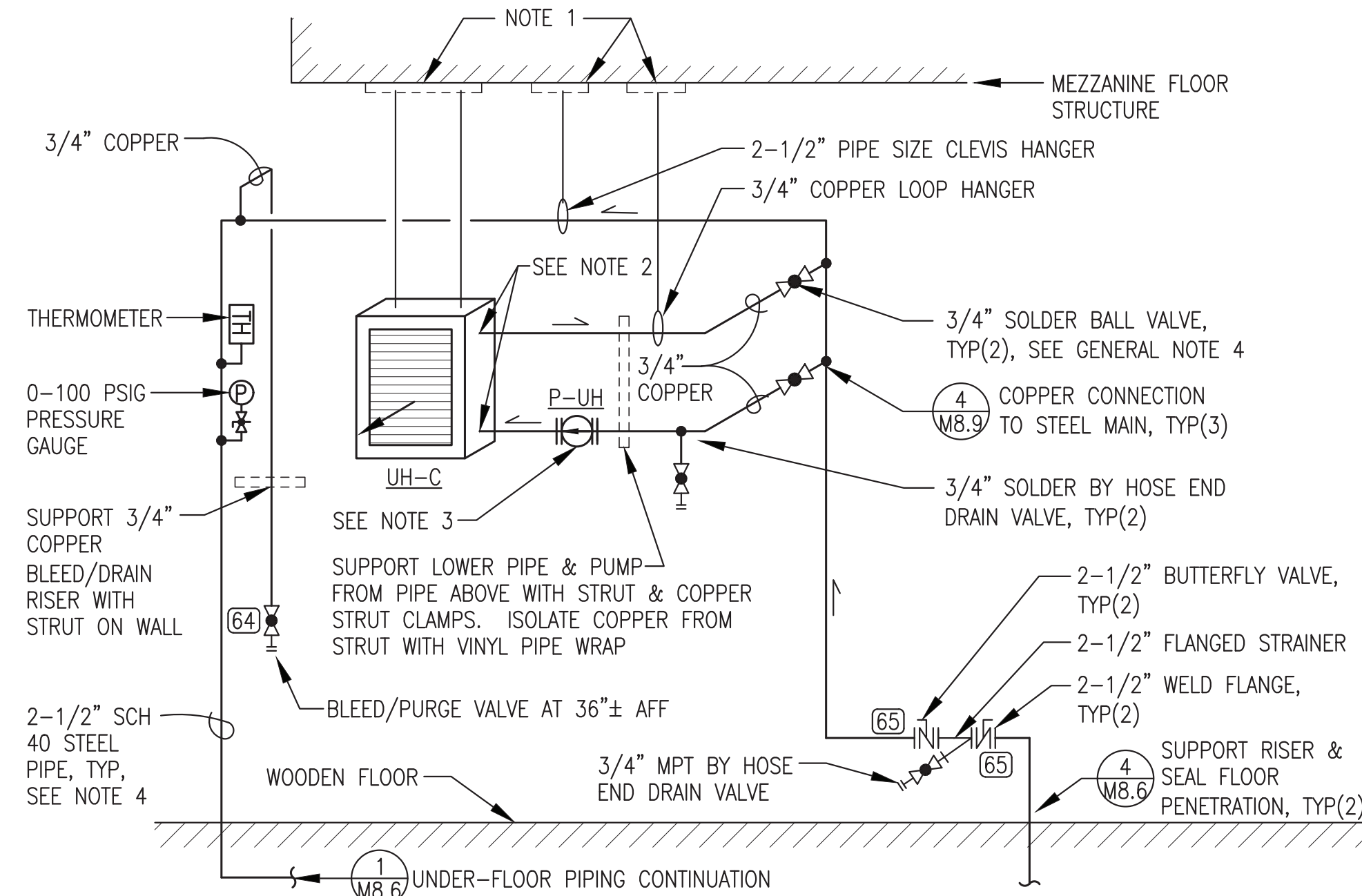

- NOTES:**
- 1) FASTEN STRUT TO MEZZANINE FLOOR JOISTS WITH 3/8"x2" LAG BOLTS AND CONNECT 3/8" ALLTHREAD WITH DOUBLE NUT AND SQUARE WASHER.
  - 2) CONNECT TO UNIT HEATER WITH 3/4" MPTxFTG ADAPTER.
  - 3) PUMP WITH 3/4" SOLDER SHUT OFF FLANGES. SET TO SPEED 1.
  - 4) INSULATE ALL 2-1/2" STEEL PIPE WITH 2" THICK CLOSED-CELL FOAM INSULATION AND HEAVY ALUMINUM JACKET. DO NOT INSULATE BRANCH COPPER TUBING.

**3** BUILDING B HEAT ARCTIC PIPE ENTRANCE & PIPING ISOMETRIC  
**M8.6** NO SCALE

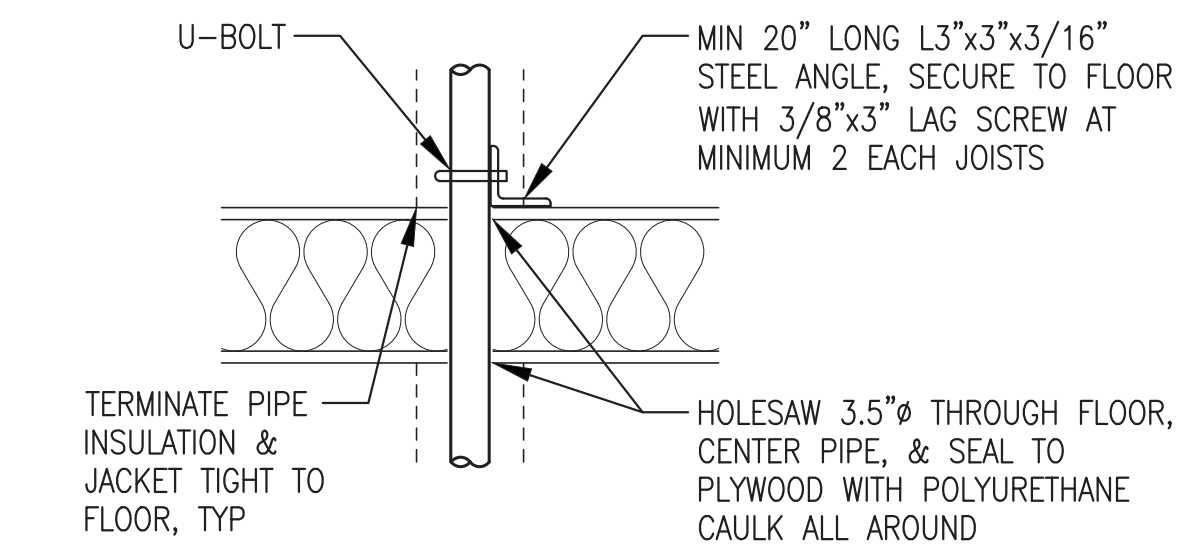

**4** STEEL PIPE FLOOR PENETRATION  
**M8.6** NO SCALE

**GENERAL NOTES:**

- 1) ALL UNDERFLOOR PIPING TO BE 2-1/2" SCH 40 STEEL PIPE WITH INSULATION AND JACKET, SEE SPECIFICATIONS.
- 2) UNDERFLOOR PIPING DIMENSIONS ARE APPROXIMATE, FIELD ROUTE AS REQUIRED TO ALIGN BELOW CUH LOCATIONS AND TO CLEAR ALL SUPPORT STRUCTURES AND OTHER UNDERFLOOR UTILITIES.
- 3) SEE OVERALL PLAN SHEET M8.1 FOR CONTINUATION OF BURIED HEAT RECOVERY MAINS.
- 4) CLOSE ISOLATION VALVES UNTIL AFTER PIPING MAINS HAVE BEEN FLUSHED. OPEN VALVES TO FLUSH AND PURGE BRANCH PIPING. SEE NOTES SHEET M8.1.

ISSUED FOR  
 CONSTRUCTION  
 DECEMBER 2022



PROJECT: NAPASKIAK POWER SYSTEM UPGRADE		
TITLE: HEAT RECOVERY SYSTEM BUILDING B ENLARGED PLANS & DETAILS		
DRAWN BY: JTD	SCALE: AS NOTED	
DESIGNED BY: BCG	DATE: 12/15/22	
FILE NAME: NAPS PP M8	SHEET:	<b>M8.6</b>
PROJECT NUMBER:		



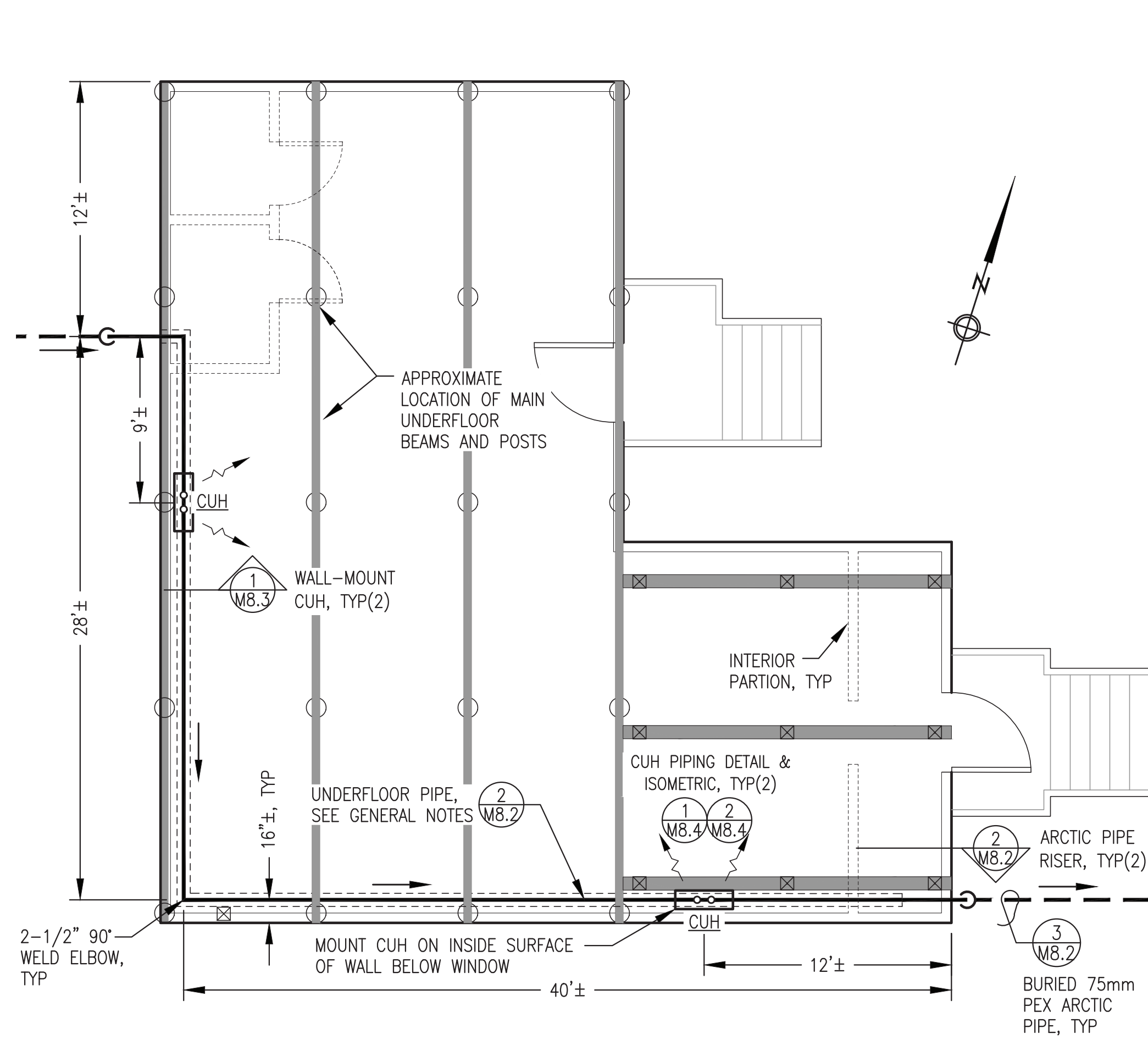

1 BUILDING C BINGO HALL ENLARGED UNDERFLOOR PIPING PLAN  
 M8.7 3/16"=1'-0"

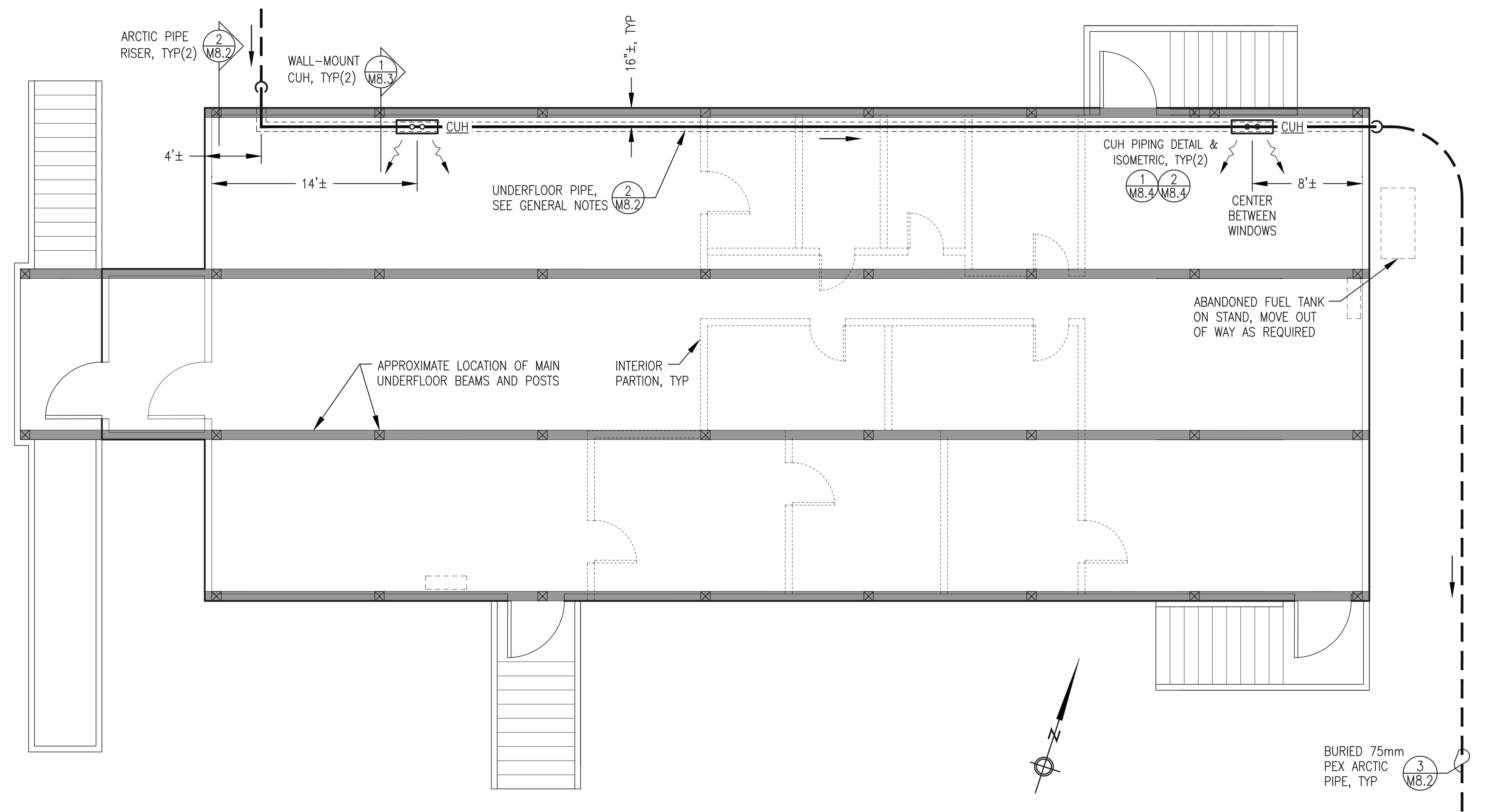

2 BUILDING D HEADSTART ENLARGED UNDERFLOOR PIPING PLAN  
 M8.7 3/16"=1'-0"

- GENERAL NOTES:**
- 1) ALL UNDERFLOOR PIPING TO BE 2-1/2" SCH 40 STEEL PIPE WITH INSULATION AND JACKET, SEE SPECIFICATIONS
  - 2) UNDERFLOOR PIPING DIMENSIONS ARE APPROXIMATE, FIELD ROUTE AS REQUIRED TO ALIGN BELOW CUH LOCATIONS AND TO CLEAR ALL SUPPORT STRUCTURES AND OTHER UNDERFLOOR UTILITIES.
  - 3) SEE OVERALL PLAN SHEET M8.1 FOR CONTINUATION OF BURIED HEAT RECOVERY MAINS.

ISSUED FOR  
 CONSTRUCTION  
 DECEMBER 2022

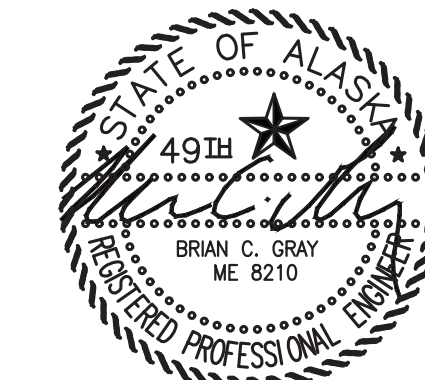

ALASKA ENERGY AUTHORITY	
PROJECT: NAPASKIAK POWER SYSTEM UPGRADE	
TITLE: HEAT RECOVERY SYSTEM BUILDINGS C & D ENLARGED PLANS	
 Gray Stassel Engineering, Inc. P.O. 111405, Anchorage, AK 99511 (907)349-0100	DRAWN BY: JTD DESIGNED BY: BCG FILE NAME: NAPS PP M8 PROJECT NUMBER:
SCALE: AS NOTED DATE: 12/15/22 SHEET: M8.7	

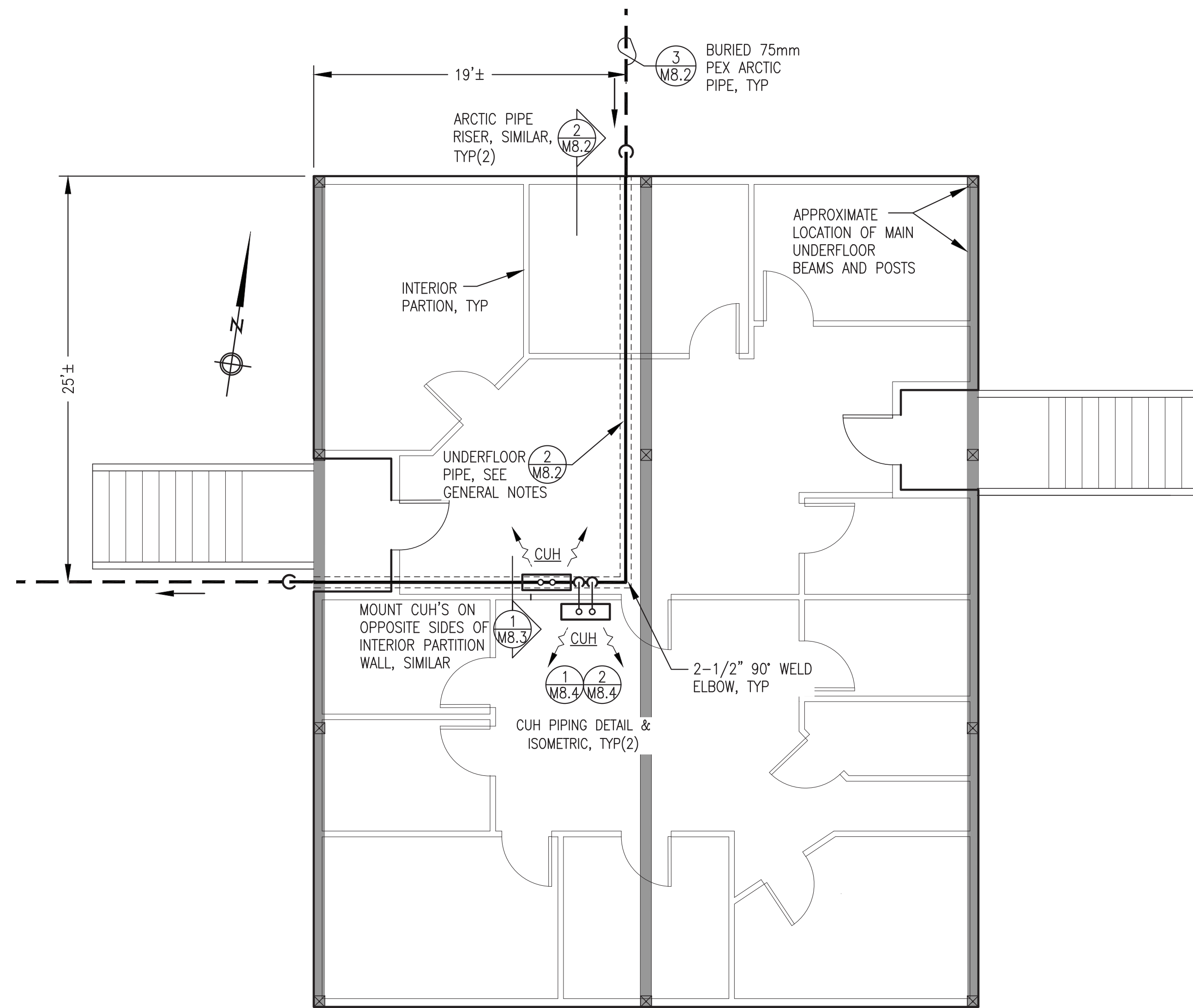

1 BUILDING E VPSO ENLARGED PIPING PLAN  
M8.8 3/16"=1'-0"

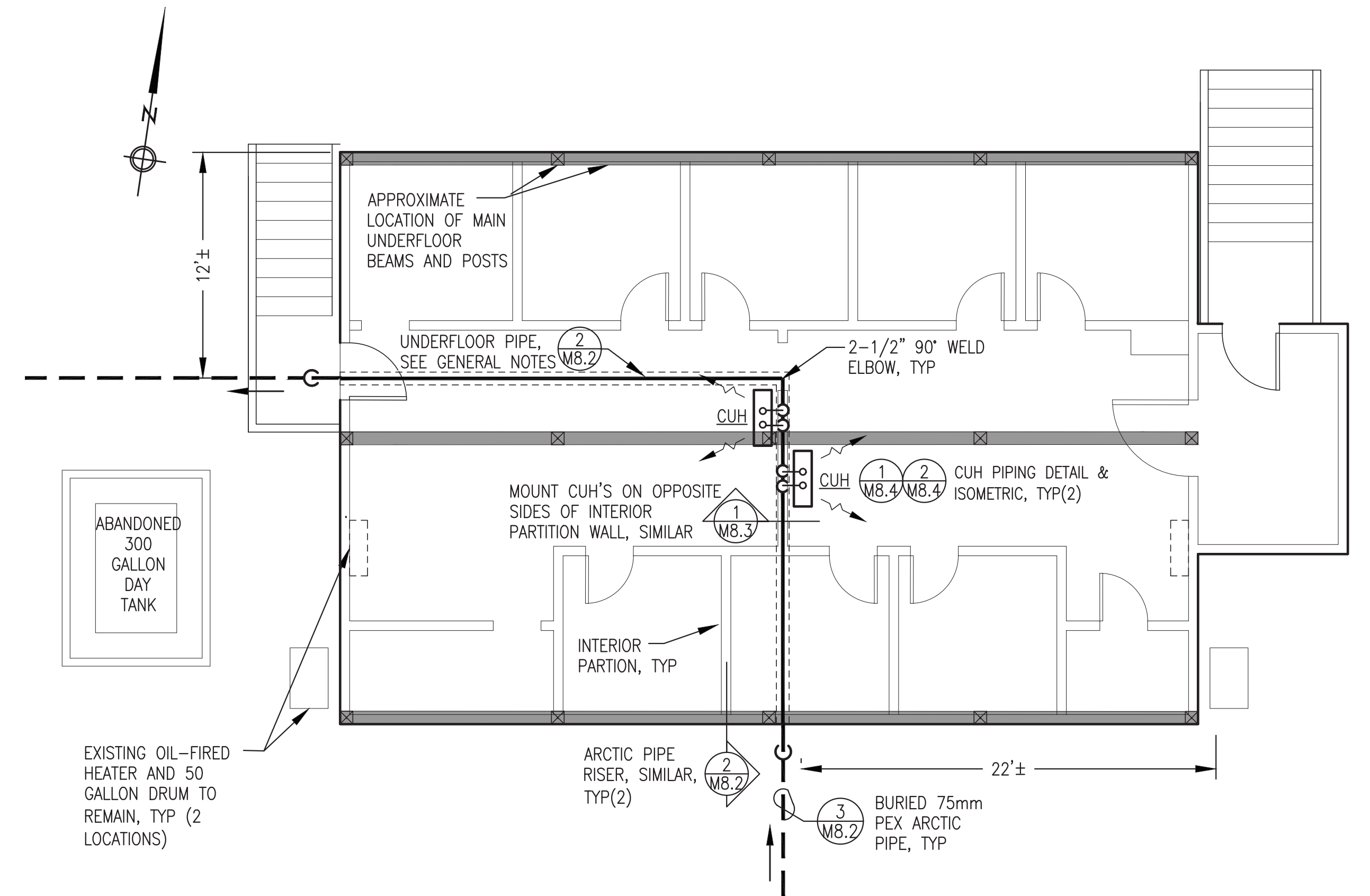

2 BUILDING F OLD OFFICE BUILDING ENLARGED UNDERFLOOR PIPING PLAN  
M8.8 3/16"=1'-0"

**GENERAL NOTES:**

- 1) ALL UNDERFLOOR PIPING TO BE 2-1/2" SCH 40 STEEL PIPE WITH INSULATION AND JACKET, SEE SPECIFICATIONS
- 2) UNDERFLOOR PIPING DIMENSIONS ARE APPROXIMATE, FIELD ROUTE AS REQUIRED TO ALIGN BELOW CUH LOCATIONS AND TO CLEAR ALL SUPPORT STRUCTURES AND OTHER UNDERFLOOR UTILITIES.
- 3) SEE OVERALL PLAN SHEET M8.1 FOR CONTINUATION OF BURIED HEAT RECOVERY MAINS.

ISSUED FOR  
CONSTRUCTION  
DECEMBER 2022



ALASKA ENERGY AUTHORITY	
PROJECT: NAPASKIAK POWER SYSTEM UPGRADE	
TITLE: HEAT RECOVERY SYSTEM BUILDINGS E & F ENLARGED PLANS	
 Gray Stassel Engineering, Inc. P.O. 111405, Anchorage, AK 99511 (907)349-0100	DRAWN BY: JTD DESIGNED BY: BCG FILE NAME: NAPS PP M8 PROJECT NUMBER:
SCALE: AS NOTED DATE: 12/15/22 SHEET: M8.8	

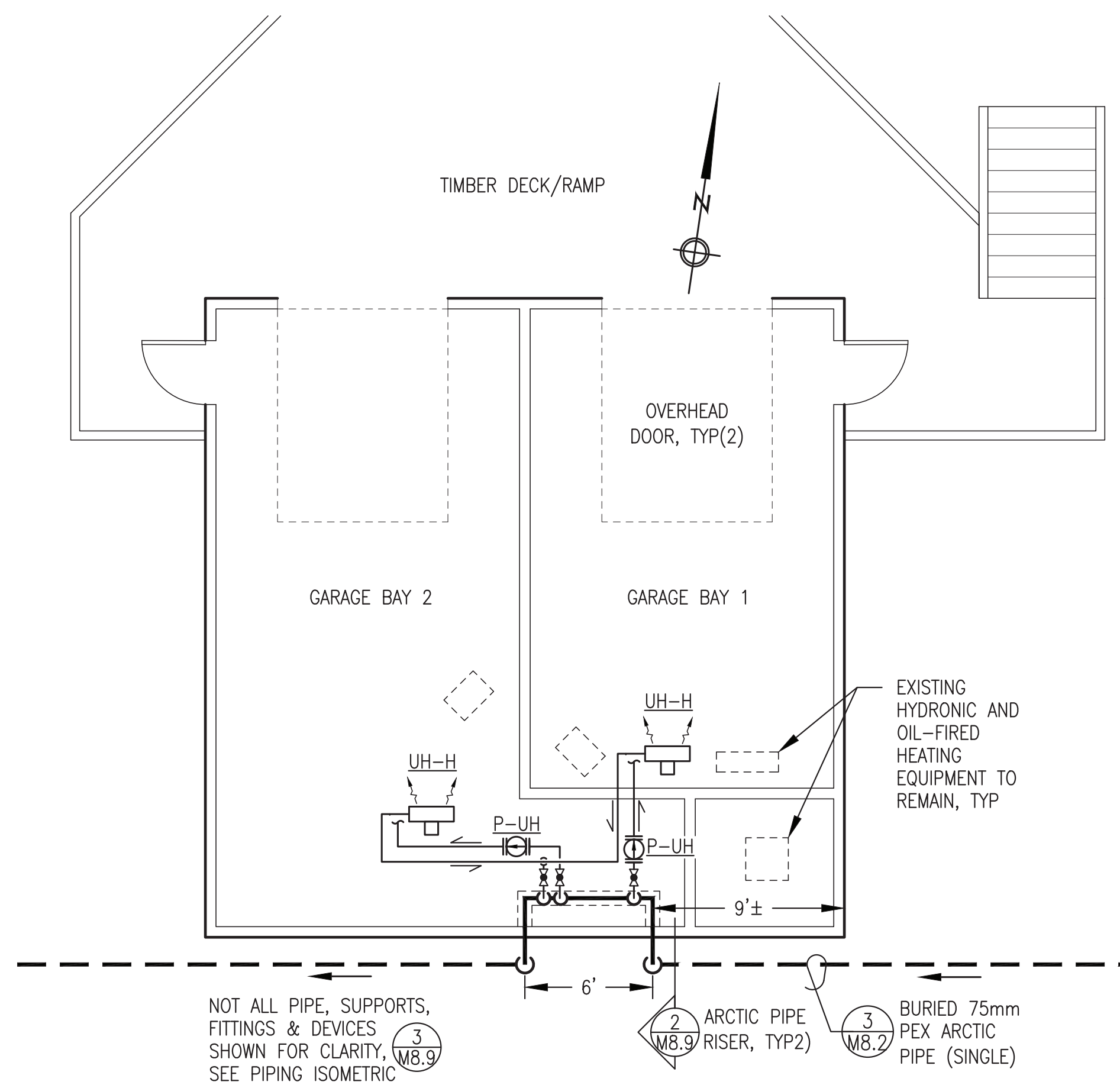

**1** BUILDING G GARAGE ENLARGED PIPING PLAN  
M8.9 3/16"=1'-0"

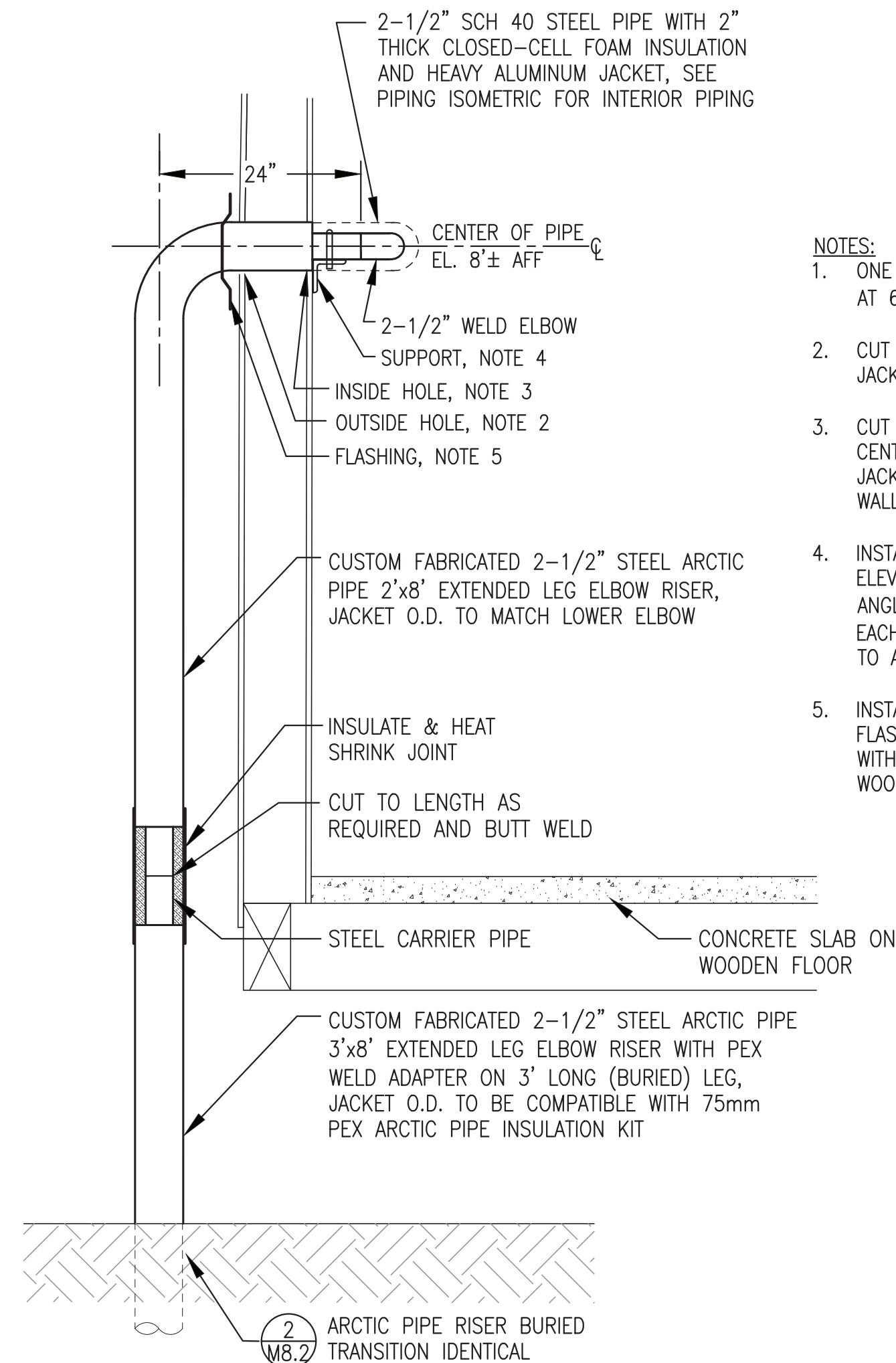

**2** ARCTIC PIPE RISER AT GARAGE BUILDING G  
M8.9 3/4"=1'-0"

**NOTES:**

- ONE ARCTIC PIPE ENTRY SHOWN, PROVIDE TWO IDENTICAL AT 6' O.C.
- CUT OUTSIDE HOLE 1/2" LARGER THAN ARCTIC PIPE JACKET.
- CUT INSIDE HOLE 1/2" LARGER THAN CARRIER PIPE, CENTER PIPE IN HOLE, & INSERT ARCTIC PIPE UNTIL JACKET TOUCHES INTERIOR WALL. SEAL CARRIER PIPE TO WALL WITH POLYURETHANE CAULK ALL AROUND.
- INSTALL 4' LONG SECTION L3"x3"x3/16" STEEL ANGLE AT ELEVATION OF BOTTOM OF STEEL CARRIER PIPE. SECURE ANGLE TO WALL WITH 3/8"x3" LAG SCREW AT MINIMUM 3 EACH WALL STUDS. SECURE 2-1/2" STEEL CARRIER PIPE TO ANGLE WITH U-BOLT.
- INSTALL MULTI-FLASH #5 RETROFIT MF501BA WALL FLASHING OVER ARCTIC PIPE. SEAL TO WALL SURFACE WITH POLYURETHANE CAULKING & FASTEN WITH STAINLESS WOOD SCREWS ALL AROUND.

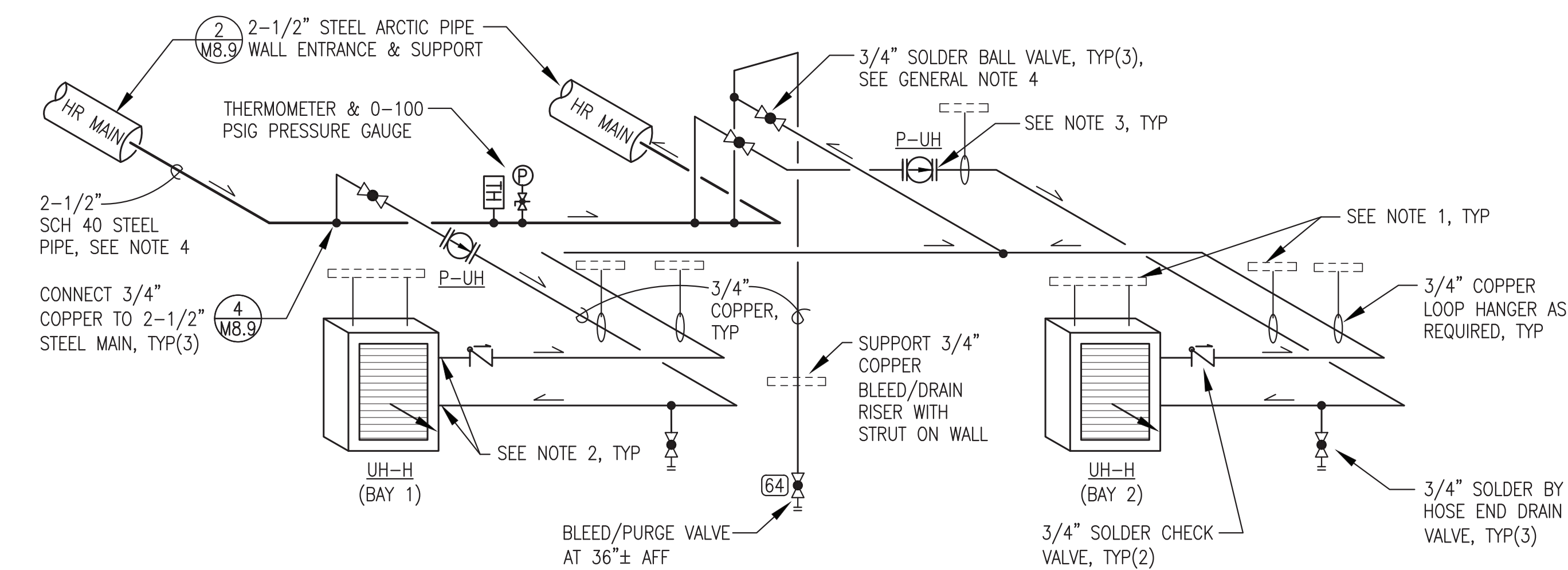

- NOTES:**
- FASTEN STRUT TO ROOF STRUCTURE WITH 3/8"x2" LAG BOLTS AND CONNECT 3/8" ALLTHREAD WITH DOUBLE NUT AND SQUARE WASHER.
  - CONNECT TO UNIT HEATER WITH 3/4" MPTxFTG ADAPTER.
  - PUMP WITH 3/4" SOLDER FLANGES. SET TO SPEED 1.
  - INSULATE ALL 2-1/2" STEEL PIPE WITH 2" THICK CLOSED-CELL FOAM INSULATION AND HEAVY ALUMINUM JACKET. DO NOT INSULATE BRANCH COPPER TUBING.

**3** BUILDING G PIPING ISOMETRIC  
M8.9 NO SCALE

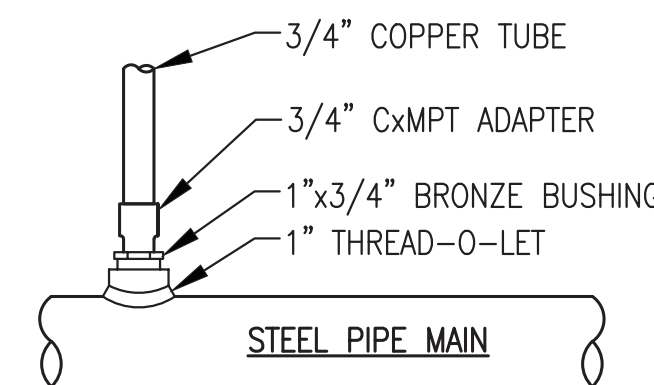

**NOTE:** FOR COPPER TUBE DIRECT CONNECTION INSTALL THREAD-0-LET ONE PIPE SIZE LARGER WITH THREADED BRONZE BUSHING FOR COPPER TO STEEL SEPARATION.

**4** DIRECT CONNECTION TO STEEL MAIN  
M8.9 NO SCALE

**GENERAL NOTES:**

- PIPING DIMENSIONS ARE APPROXIMATE, FIELD ROUTE AS REQUIRED TO CLEAR ALL SUPPORT STRUCTURES.
- SEE OVERALL PLAN SHEET M8.1 FOR CONTINUATION OF BURIED HEAT RECOVERY MAINS.
- CLOSE ISOLATION VALVES UNTIL AFTER PIPING MAINS HAVE BEEN FLUSHED. CRACK VALVES TO FLUSH AND PURGE BRANCH PIPING. SEE NOTES SHEET M8.1.

ISSUED FOR CONSTRUCTION  
DECEMBER 2022

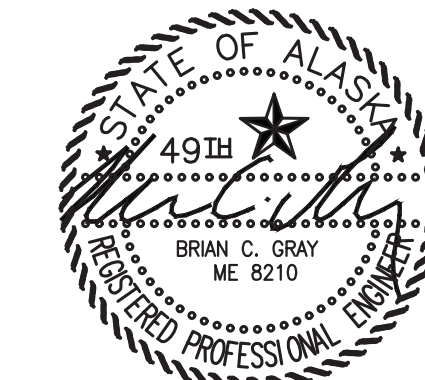

PROJECT: NAPASKIAK POWER SYSTEM UPGRADE	
TITLE: HEAT RECOVERY SYSTEM BUILDING G ENLARGED PLAN & DETAILS	
DESIGNED BY: BCG	SCALE: AS NOTED
FILE NAME: NAPS PP M8	DATE: 12/15/22
P.O. 111405, Anchorage, AK 99511 (907)349-0100	SHEET: M8.9

**Gray Stassel Engineering, Inc.**

DRAWN BY: JTD  
PROJECT NUMBER:

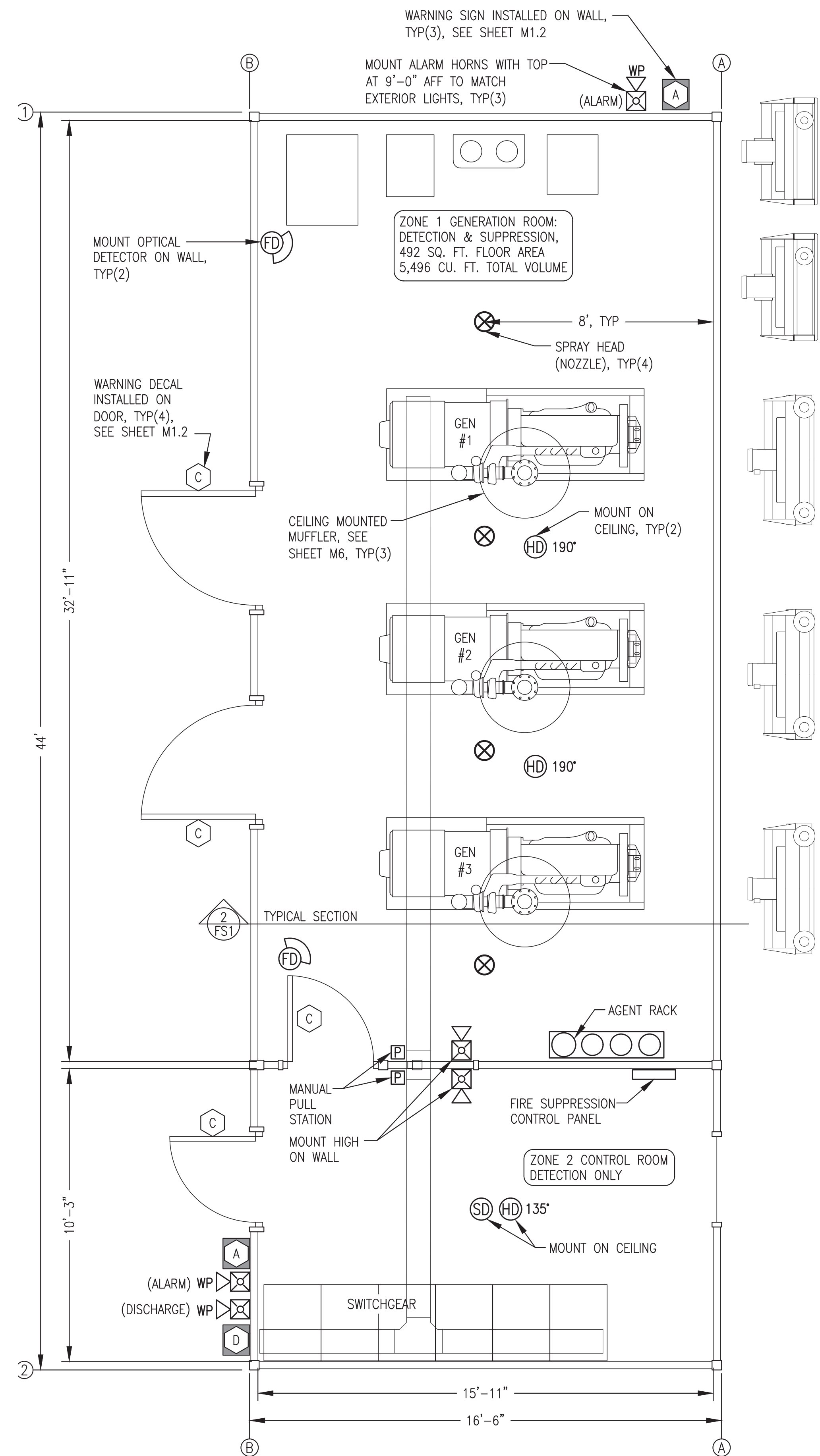

**1** FIRE SUPPRESSION SYSTEM PLAN  
3/8"=1'-0"

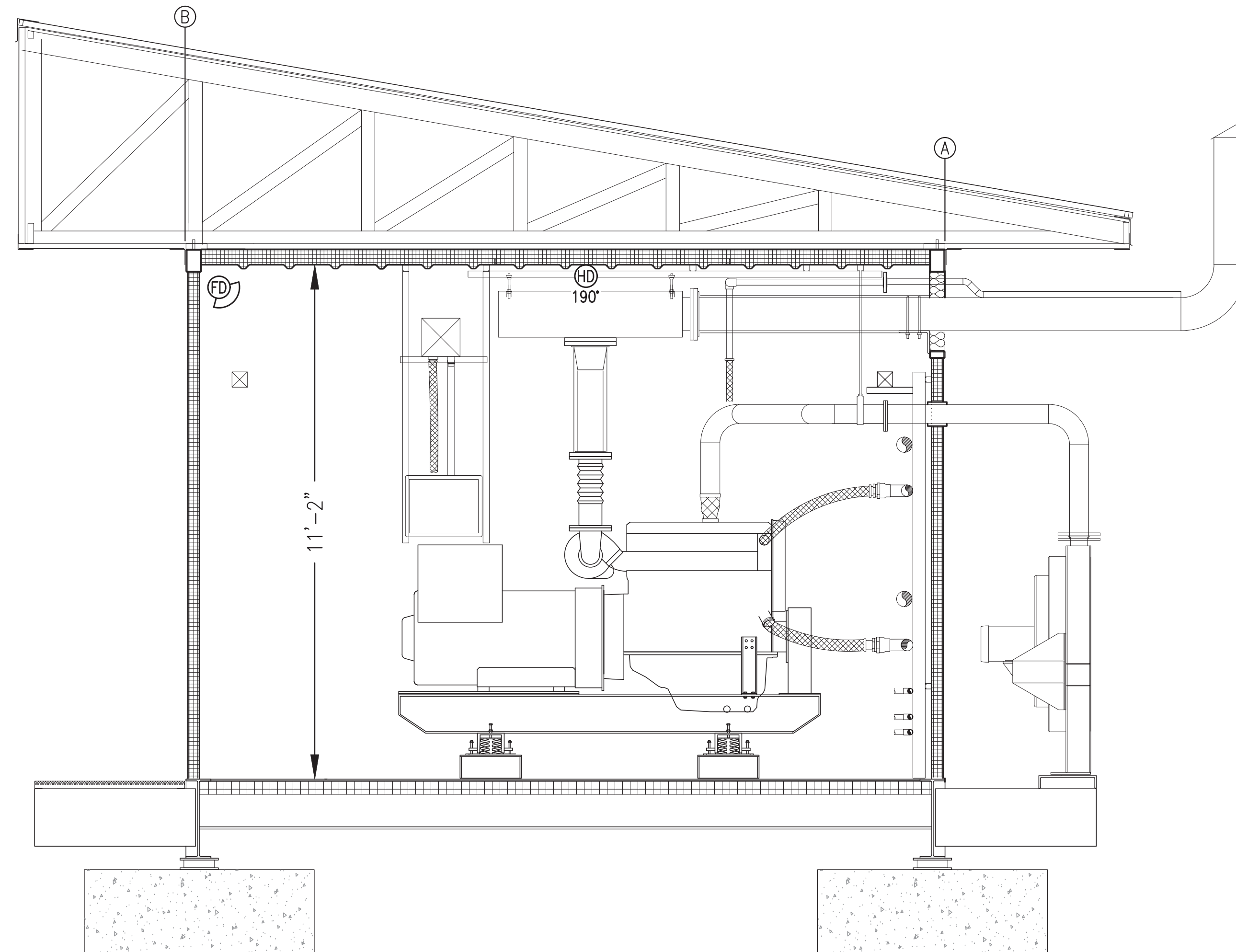

**2** TYPICAL SECTION THROUGH BUILDING  
3/8"=1'-0"

FIRE SUPPRESSION SYMBOL LEGEND			
SYMBOL	DESCRIPTION	SYMBOL	DESCRIPTION
HD 135	NORMAL TEMP. (135°F) DETECTOR	P	MANUAL PULL STATION
HD 190	HIGH TEMP. (190°F) DETECTOR	WP	INTERIOR ALARM HORN/STROBE
FD	FLAME (OPTICAL) DETECTOR	WP	EXTERIOR ALARM HORN/STROBE
SD	SMOKE (IONIZATION) DETECTOR		

FIRE SUPPRESSION PLACARD SCHEDULE (SEE SHEET M1.2)	
SYMBOL	DESCRIPTION
A	"FIRE ALARM"
C	"CAUTION, ROOM PROTECTED BY WATER MIST FIRE PROTECTION SYSTEM, IN CASE OF FIRE KEEP DOOR CLOSED AND DO NOT ENTER"
D	"FLASHING LIGHT MEANS FIRE SUPPRESSION AGENT HAS DISCHARGED"

FIRE SUPPRESSION WIRE SCHEDULE			
SYMBOL	CIRCUIT DESCRIPTION	WIRE TYPE	WIRE COLOR
A	24V DC POWER	#14 AWG SOLID	RED & BLACK
B	DETECTION CIRCUITS	#14 AWG SOLID	BLUE & YELLOW
C	ANNUNCIATION ALARM	#14 AWG SOLID	BROWN & ORANGE
D	ANNUNCIATION DISCHARGE	#14 AWG SOLID	WHITE, & GRAY
E	24V DC AUX POWER	#14 AWG SOLID	RED & BLACK WITH GRAY STRIPE

**GENERAL NOTES:**

- INTERIOR FINISH OF ALL WALLS AND CEILING METAL SIDING. INTERIOR FINISH OF FLOOR WELDED STEEL PLATE. CEILING HEIGHT IN ALL ROOMS 11'-2" ABOVE FINISHED FLOOR.
- ALL DOORS SELF-CLOSING WITH GASKETS. ALL BUILDING PIPING AND CONDUIT PENETRATIONS SEALED LIQUID TIGHT. ALL BUILDING DUCT PENETRATIONS EQUIPPED WITH MOTORIZED DAMPERS THAT CLOSE ON GENERATOR SHUT DOWN.

ALL WORK ON THIS SHEET WAS PERFORMED AS PART OF THE PRIOR MODULE ASSEMBLY CONTRACT AND IS SHOWN HERE FOR REFERENCE. SEE SPECIFICATION 21 13 30 FOR DELINEATION OF FINAL RE-ASSEMBLY, TESTING, AND COMMISSIONING THAT IS INCLUDED IN THE ON SITE SCOPE.

ISSUED FOR CONSTRUCTION  
JULY 2022

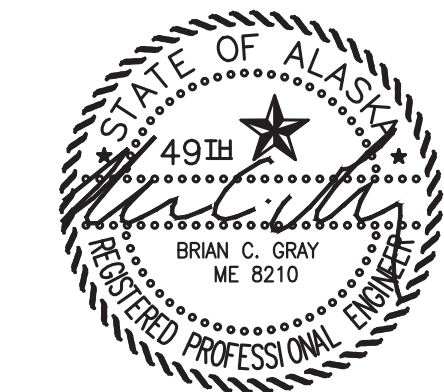

ALASKA ENERGY AUTHORITY		
PROJECT: NAPASKIAK POWER SYSTEM UPGRADE		
TITLE: FIRE SUPPRESSION SYSTEM PLAN, SECTION, LEGEND, & NOTES		
DESIGNED BY: BCG	DRAWN BY: BCG	SCALE: AS NOTED
FILE NAME: NAPS PP FS1	DESIGNED BY: BCG	DATE: 7/29/22
P.O. 111405, Anchorage, AK 99511 (907)349-0100	PROJECT NUMBER:	SHEET: <b>FS1</b>